

Elettropompe Sommerse

Submersed Electropump

Technical Catalogue

Catalogo Tecnico(50Hz)

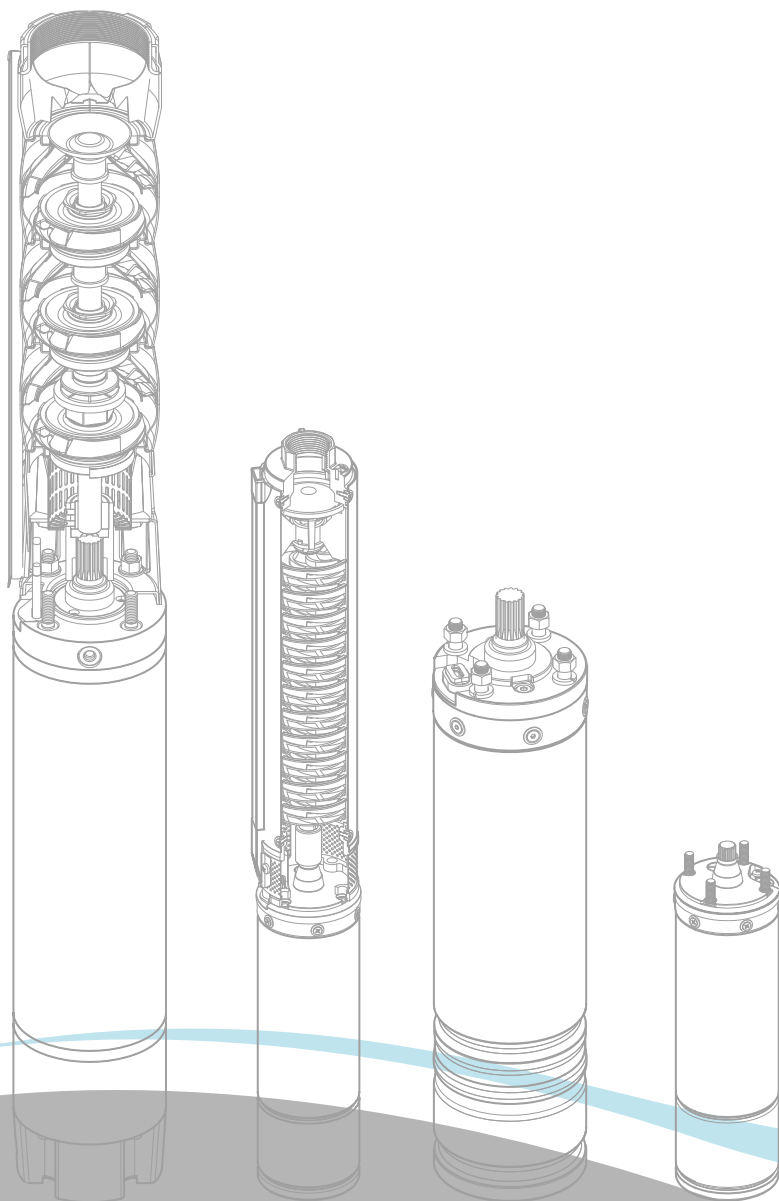

IRCEM
WATER PUMPS

CONTENTS

3OS series 3" oil-filled submersible motors	1
DL-BM series 3" submersible electric pumps	3
35OS series 3,5" oil-filled submersible motors	9
YL-BG series 3,5" submersible electric pumps.....	11
4OS series 4" oil-filled submersible motors	19
BH series 4" submersible electric pumps	21
BM series 4" submersible electric pumps	35
SP series 4" submersible electric pumps	49
ACQUAJET series 4" submersible electric pumps	60
5OS series 5" oil-filled submersible motors	64
6OS series 6" oil-filled submersible motors	66
6OST series 6" oil-filled submersible motors	68
OMSY6 series 6" water-filled submersible motors	70
OMSJ6 series 6" water-filled submersible motors	72
OMSY8 series 8" water-filled submersible motors	74
OMSJ8 series 8" water-filled submersible motors	76
TH series 5" submersible pumps	78
BF series 6" submersible pumps	84
BP series 6" submersible pumps	92
DP series 8" submersible pumps	106
CBS series single-phase electric panels	111
CBL series single-phase electric panels	112
CBS series three-phase electric panels (0,37~7,5kW)	113
CBS series three-phase electric panels (9,2~15kW)	114

30S SERIES 3" OIL-FILLED SUBMERSIBLE MOTORS

- The state-of-art design and choice of component materials ensure optimum operating performances, superior quality, reliability and ease of installation.

SPECIFICATIONS

- Rewindable stator.
- Winding insulation: Class F .
- Protection grade: IP68.
- Filling fluid in compliance with standards concerning oils contact with foodstuffs and with the purity requirements specified by the annex to G.U. no. 104 of 20/04/1973; it also complies with F.D.A. (FOOD AND DRUG ADMINISTRATION) standards.
- Large compensation bellows for the expansion of the internal liquid.
- Mechanical seal with sand protection.
- Removable cable connector.
- Maximum immersion depth: 150 m.
- Maximum number of starts per hour at regular intervals: 30 for direct start.
- Maximum allowable voltage fluctuations over the rated voltage: $\pm 10 \%$.

MODELS

- Single-phase:
from 0,25 to 1,5 kW, 220 V, 50 Hz.
- Three-phase:
from 0,37 to 1,5 kW, 380 V, 50 Hz.

OPTIONAL FEATURES

- Different voltage and frequency.
- Different materials.



IDENTIFICATION CODE

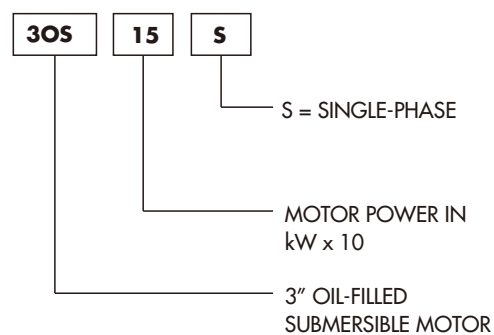

EXAMPLE OF MOTOR TYPE

30S15S

3" oil-filled submersible motor, single-phase, 1,5kW (2,0 Hp).

3OS SERIES MOTOR CROSS SECTION AND TABLE OF MATERIAL

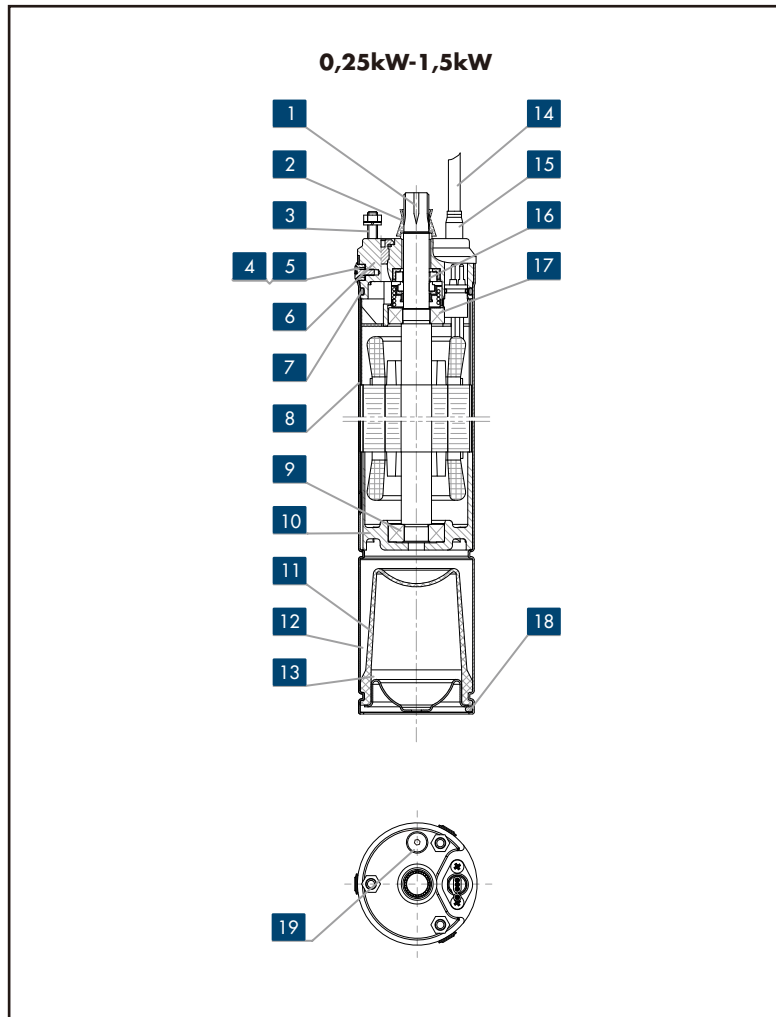

REF.N.	PART	MATERIAL	STANDARD
1	Shaft extension	Stainless steel	AISI 420
2	Sand protection	NBR	-----
3	Screw	Stainless steel	AISI 304
4	Pin	Stainless steel	AISI 304
5	Screw	Stainless steel	AISI 304
6	Upper support	Cast iron & Stainless steel	
7	O-ring	NBR	-----
8	Motor shell	Stainless steel	AISI 304
9	Ball bearing	-----	-----
10	Lower support	Cast iron	ASTM 200A
11	Compensation bellow	NBR	-----
12	Cooling liquid	Non toxic oil	-----
13	Lower protection	Stainless steel	AISI 304
14	Cable	-----	-----
15	Cable connector sleeve	Stainless steel	AISI 304
16	Mechanical seal	Carbon/Ceramic	-----
17	Ball bearing	-----	-----
18	Snap ring	Stainless steel	AISI 304
19	Filling screw	Stainless steel	AISI 304

DIMENSIONS AND WEIGHTS AT 50 Hz

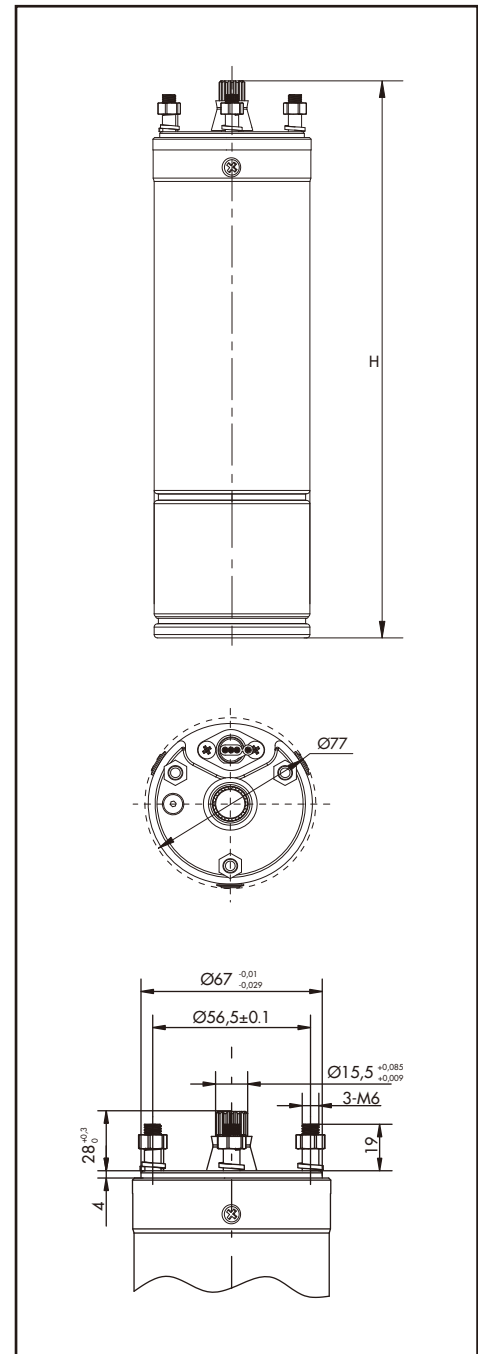

MOTOR TYPE	POWER		H mm	WEIGHT kg
	kW	Hp		
3OS02S	0,25	0,33	345	5,4
3OS03S	0,37	0,5	375	6,2
3OS03T				
3OS05S	0,55	0,75	410	7,1
3OS05T				
3OS07S	0,75	1	445	8
3OS07T				
3OS09S	0,95	1,3	480	9,1
3OS09T				
3OS11S	1,1	1,5	530	10,3
3OS11T				
3OS15S	1,5	2	580	11,8
3OS15T				

DL-BM SERIES 3" SUBMERSIBLE ELECTRIC PUMPS

*COST-EFFECTIVE VERSION

- Cost-effective submersible electric pumps ensure low cost, high efficiency, better performance and reliability.

APPLICATIONS

- Water supply from deep well.
- Agricultural irrigation.
- Pressure boosting.
- Industrial application.

SPECIFICATIONS

- Delivery: up to 6m³/h at 2850 rpm.
- Head: up to 180 m at 2850 rpm.
- Maximum pump overall diameter (cable cover included): 80 mm.
- Maximum permissible quantity of sand: 150 g/m³.
- Delivery port Rp1"1/4.

MOTOR

- 3OS single-phase version:
from 0,25 to 1,5 kW, 220 V, 50 Hz.
- 3OS three-phase version:
from 0,37 to 1,5 kW, 380 V, 50 Hz.
- Horizontal operation: 3OS up to 1,5 kW.
- Maximum temperature of water in contact with motor: 35°C .

CONSTRUCTION & CHARACTERISTICS

- Cost-effective construction ensures low cost, high efficiency, better performance and reliability.
- Abrasion resistant construction, floating impellers ensure optimum resistance to abrasion.
- The hexagonal pump shaft guarantees an effective impeller driving.
- A non-return valve is fitted at the discharge to prevent back flow of water and alleviate water hammer to the pump, safeguarding impellers and diffusers.
- The DL-BM series pumps can be coupled with the 3OS motors.
- Vertical and horizontal installation .
- Standard and special versions available.

OPTIONAL FEATURES

- Different voltage and frequency.
- Different materials.



DL-BM SERIES

HYDRAULIC PERFORMANCE RANGE AT 50 Hz

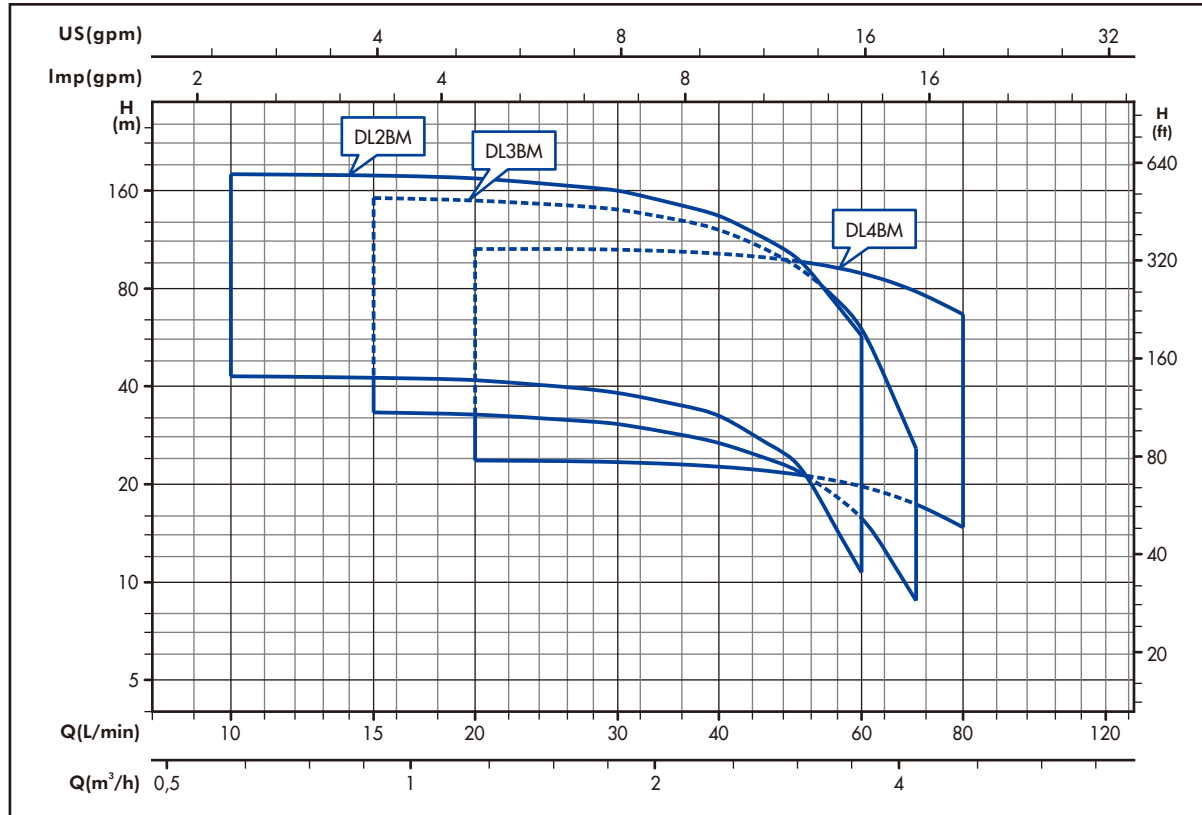

IDENTIFICATION CODE

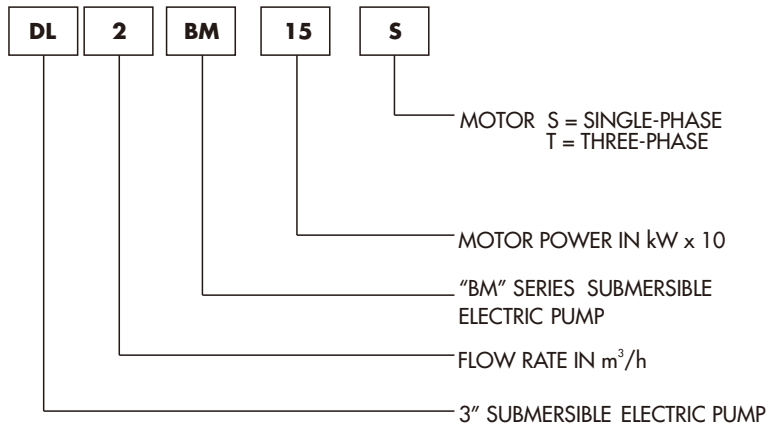

EXAMPLE OF PUMP TYPE

DL2BM15S

DL-BM series 3" submersible electric pump with flow rate of 2 m³/h; and single-phase 1,5 kW (2,0 Hp) motor.



DL2-4BM SERIES

PUMP SECTION AND LIST OF MAIN COMPONENTS MATERIAL

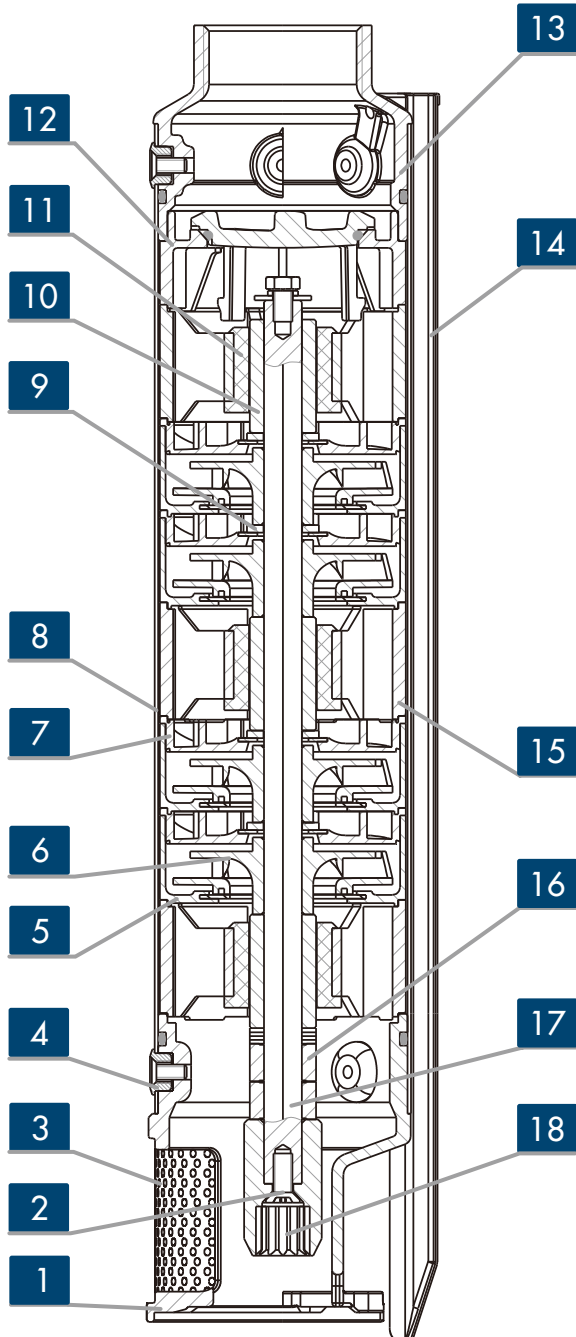

REF.N.	PART	MATERIAL	STANDARD
1	Lower support	Precision-cast stainless steel	AISI 304
2	Screw	Stainless steel	AISI 304
3	Filter	Stainless steel	AISI 304
4	Pin	Stainless steel	AISI 304
5	Guide plate	PC	-----
6	Impeller	POM	-----
7	Diffuser	PC	-----
8	Outer sleeve	Stainless steel	AISI 304
9	Wearing gasket	NBR & Stainless steel	----- & AISI 304
10	Shaft sleeve	Stainless steel	AISI 304
11	Bush bearing	TPU	-----
12	Upper support	PC	-----
13	Delivery port	Precision-cast stainless steel	AISI 304
14	Cable guard	Stainless steel	AISI 304
15	Intermediate support	PC	-----
16	Shaft sleeve	PPO	-----
17	Shaft	Stainless steel	AISI 420
18	Coupling	Stainless steel	AISI 304

DL2BM SERIES

OPERATING CHARACTERISTICS AT 50 Hz

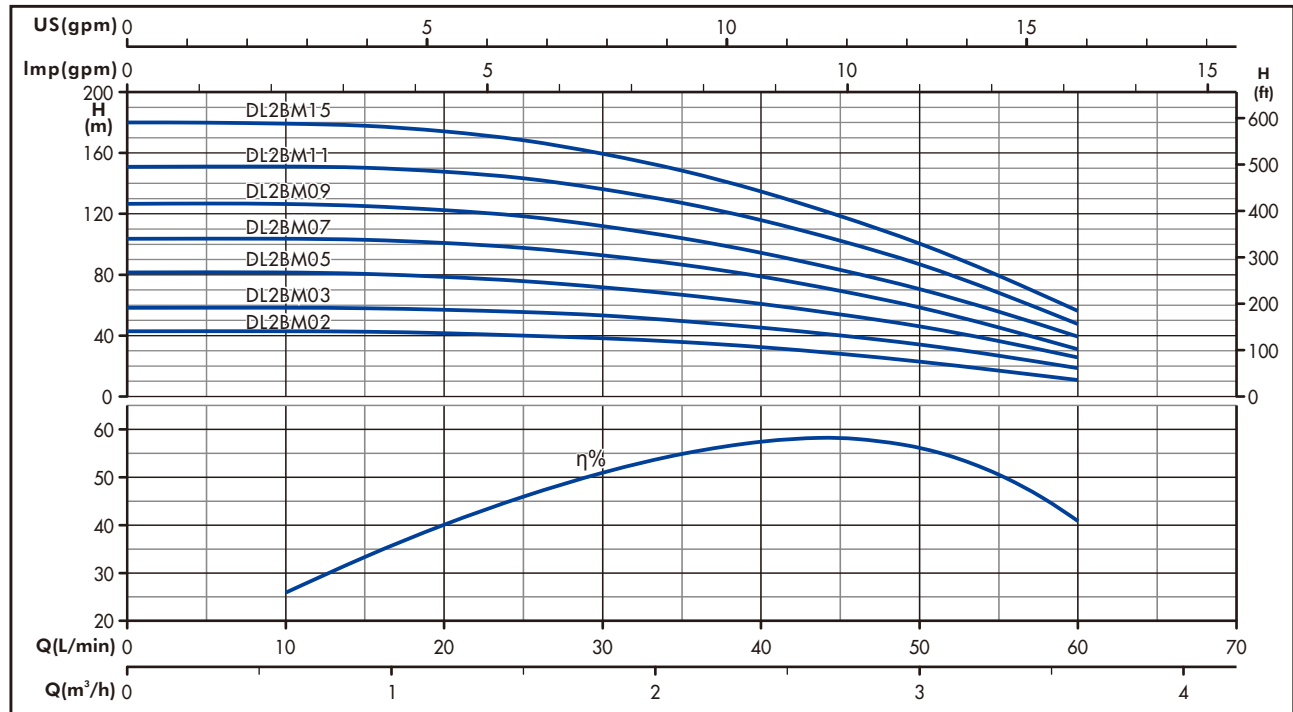

OPERATING CHARACTERISTICS AT 50 Hz

PUMP TYPE	No.OF STAGES	kW	Hp	Q=DELIVERY						
				l/min 0	10	20	30	40	50	60
				m³/h 0	0,6	1,2	1,8	2,4	3	3,6
				H=TOTAL HEAD METERS COLUMN OF WATER						
DL2BM02S	11	0,25	0,33	43	43	42	39	33	23	11
DL2BM03S	15	0,37	0,5	59	59	57	53	46	35	19
DL2BM03T										
DL2BM05S										
DL2BM05T	21	0,55	0,75	82	82	79	72	61	46	26
DL2BM07S										
DL2BM07T										
DL2BM09S	33	0,95	1,3	127	127	123	113	95	71	40
DL2BM09T										
DL2BM11S										
DL2BM11T	39	1,1	1,5	152	152	149	137	117	87	48
DL2BM15S										
DL2BM15T										
DL2BM15T	46	1,5	2	180	180	175	161	136	101	57

DIMENSIONS AND WEIGHTS AT 50 Hz

PUMP TYPE	No.OF STAGES	DN	L1 mm	L mm	PUMP WEIGHT kg	ELECTRIC PUMP WEIGHT kg
DL2BM02S	11	Rp1"1/4	483	797,5	2,6	8
DL2BM03S	15		581	925,5	2,9	9,1
DL2BM03T						
DL2BM05S						
DL2BM05T	21		757	1136,5	3,7	10,8
DL2BM07S						
DL2BM07T						
DL2BM09S	33		1049	1498,5	5,1	14,2
DL2BM09T						
DL2BM11S						
DL2BM11T	39		1225	1724,5	5,8	16,1
DL2BM15S						
DL2BM15T			46	1395	1944,5	6,2

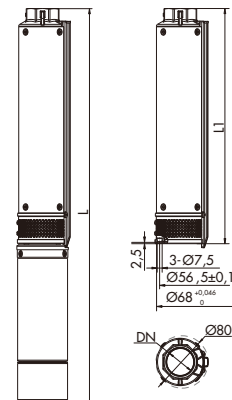

DL3BM SERIES

OPERATING CHARACTERISTICS AT 50 Hz

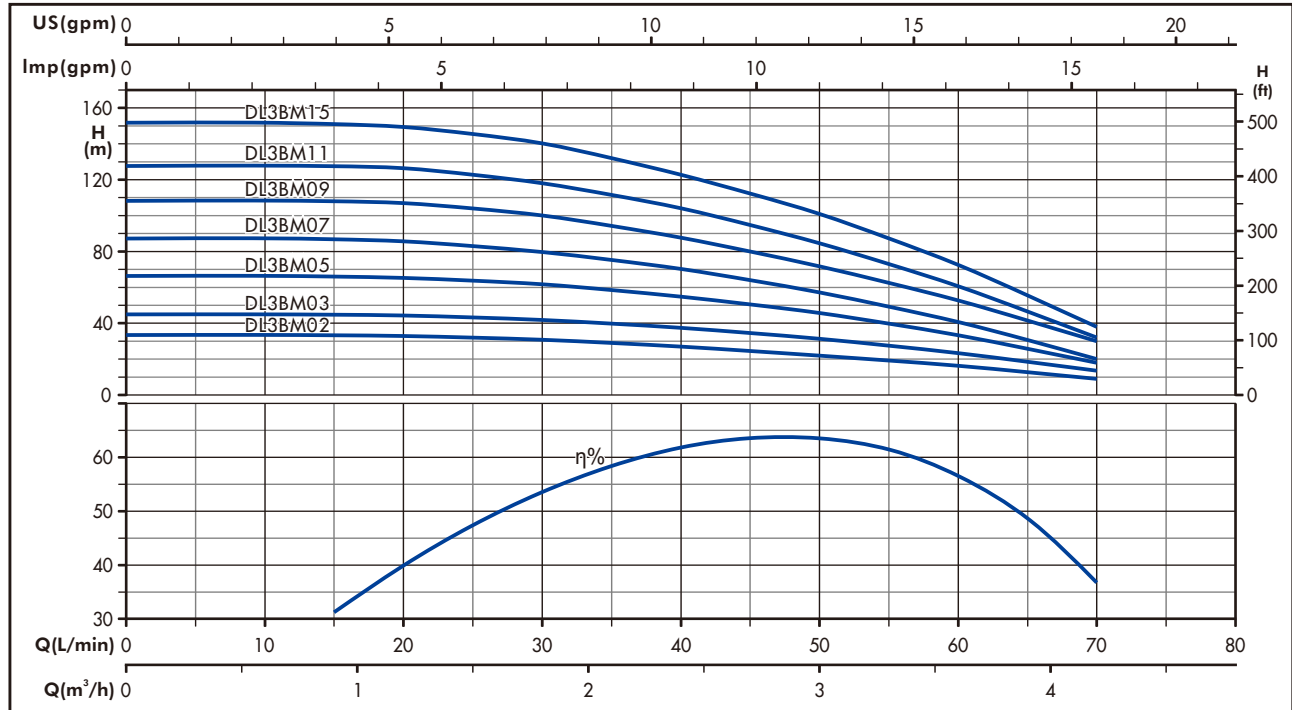

OPERATING CHARACTERISTICS AT 50 Hz

PUMP TYPE	No. OF STAGES	kW	Hp	Q=DELIVERY							
				l/min 0	10	20	30	40	50	60	70
				m³/h 0 0,6 1,2 1,8 2,4 3 3,6 4,2							
				H=TOTAL HEAD METERS COLUMN OF WATER							
DL3BM02S	8	0,25	0,33	34	34	33	31	27	22	17	9
DL3BM03S	11	0,37	0,5	45	45	45	42	38	32	24	14
DL3BM03T											
DL3BM05S	16	0,55	0,75	67	67	66	62	55	46	34	18
DL3BM05T											
DL3BM07S	21	0,75	1	88	88	86	80	71	58	41	21
DL3BM07T											
DL3BM09S	26	0,95	1,3	109	109	108	101	88	72	53	30
DL3BM09T											
DL3BM11S	31	1,1	1,5	128	128	127	119	105	85	61	32
DL3BM11T											
DL3BM15S	37	1,5	2	152	152	150	141	123	102	73	38
DL3BM15T											

DIMENSIONS AND WEIGHTS AT 50 Hz

PUMP TYPE	No. OF STAGES	DN	L1 mm	L mm	PUMP WEIGHT kg	ELECTRIC PUMP WEIGHT kg
DL3BM02S	8	Rp1"1/4	410	724,5	2	7,4
DL3BM03S	11		483	827,5	2,6	8,8
DL3BM03T						
DL3BM05S	16		635	1014,5	3	10,1
DL3BM05T						
DL3BM07S	21		757	1171,5	3,7	11,7
DL3BM07T						
DL3BM09S	26		878	1327,5	4,2	13,3
DL3BM09T						
DL3BM11S	31		1000	1499,5	4,8	15,1
DL3BM11T						
DL3BM15S	37		1176	1725,5	5,3	17,1
DL3BM15T						

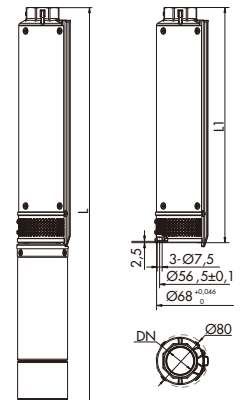

DL4BM SERIES

OPERATING CHARACTERISTICS AT 50 Hz

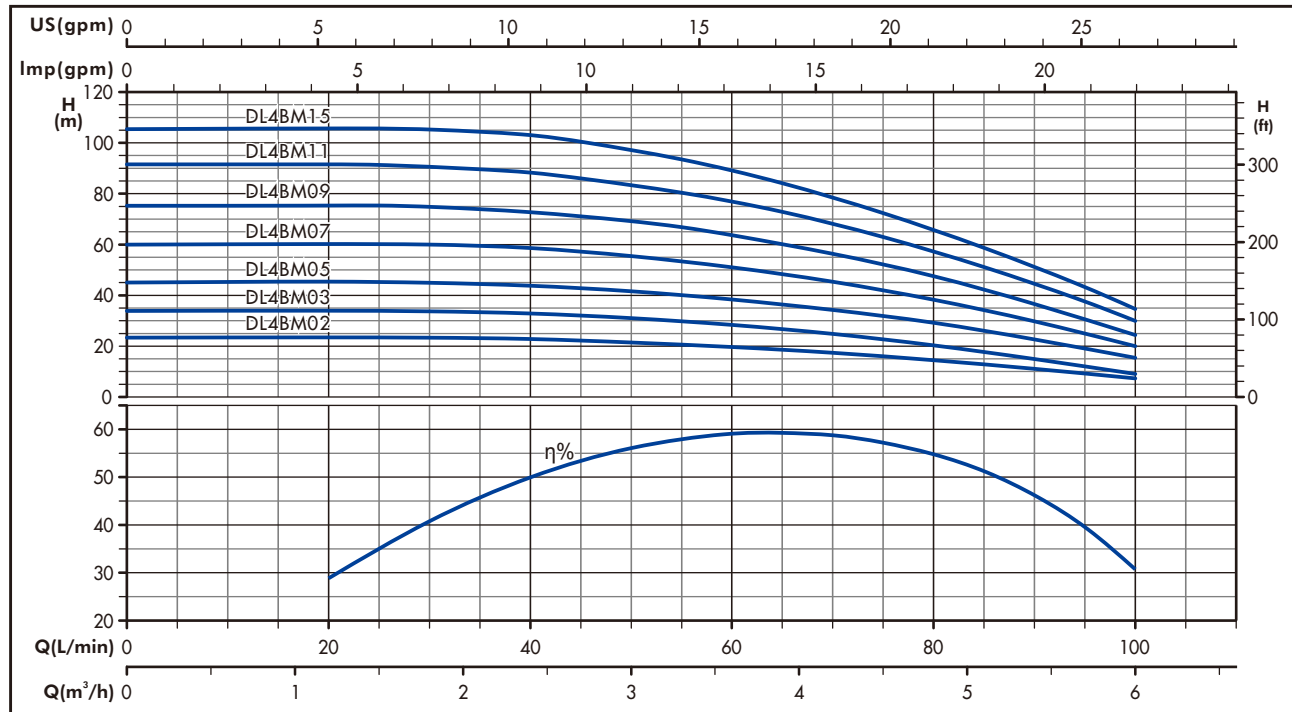

OPERATING CHARACTERISTICS AT 50 Hz

PUMP TYPE	No. OF STAGES	kW	Hp	Q=DELIVERY					
				l/min 0	20	40	60	80	100
				H=TOTAL HEAD METERS COLUMN OF WATER					
				m³/h 0	1,2	2,4	3,6	4,8	6
DL4BM02S	6	0,25	0,33	24	24	23	20	15	7
DL4BM03S	9	0,37	0,5	34	34	33	29	21	9
DL4BM03T									
DL4BM05S	12	0,55	0,75	46	46	44	39	29	15
DL4BM05T									
DL4BM07S	16	0,75	1	60	60	59	52	39	20
DL4BM07T									
DL4BM09S	20	0,95	1,3	75	75	73	64	48	24
DL4BM09T									
DL4BM11S	24	1,1	1,5	92	92	88	77	58	30
DL4BM11T									
DL4BM15S	28	1,5	2	106	106	103	90	67	35
DL4BM15T									

DIMENSIONS AND WEIGHTS AT 50 Hz

PUMP TYPE	No. OF STAGES	DN	L1 mm	L mm	PUMP WEIGHT kg	ELECTRIC PUMP WEIGHT kg
DL4BM02S	6	Rp1"1/4	395	709,5	2,1	7,5
DL4BM03S	9		485	829,5	2,5	8,7
DL4BM03T						
DL4BM05S	12		574	953,5	2,8	9,9
DL4BM05T						
DL4BM07S	16		724	1138,5	3,5	11,5
DL4BM07T						
DL4BM09S	20		844	1293,5	3,9	13
DL4BM09T						
DL4BM11S	24		963	1462,5	4,4	14,7
DL4BM11T						
DL4BM15S	28		1083	1632,5	4,9	16,7
DL4BM15T						

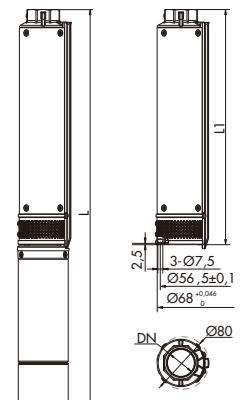

35OS SERIES 3,5" OIL-FILLED SUBMERSIBLE MOTORS

- The state-of-art design and choice of component materials ensure optimum operating performances, superior quality, reliability and ease of installation.

SPECIFICATIONS

- Rewindable stator.
- Winding insulation: Class F .
- Protection grade: IP68.
- Filling fluid in compliance with standards concerning oils contact with with the purity requirements specified by the annex to G.U. no. 104 of 20/04/1973; it also complies with F.D.A. (FOOD AND DRUG ADMINISTRATION) standards.
- Large compensation bellows for the expansion of the internal liquid.
- Oversized thrust bearings: Shaft supported by oversized angular bearings which can support thrust load up to 4000 N.
- Mechanical seal with sand protection.
- Removable cable connector.
- Maximum immersion depth: 150 m.
- Maximum number of starts per hour at regular intervals: 30 for direct start.
- Maximum allowable voltage fluctuations over the rated voltage: $220\text{ V} \pm 10\%$.

MODELS

- Single-phase:
from 0,37 to 1,7 kW, 220 V, 50 Hz.

OPTIONAL FEATURES

- Different voltage and frequency.
- Different materials.



IDENTIFICATION CODE

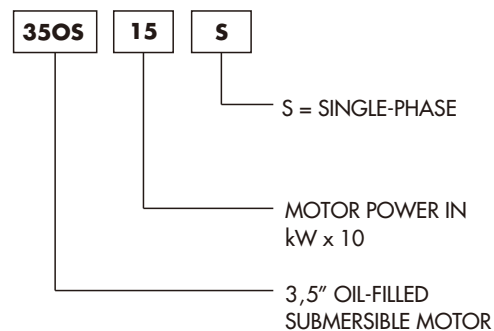

EXAMPLE OF MOTOR TYPE

35OS15S

3,5" oil-filled submersible motor, single-phase, 1,5kW (2 Hp).

350S SERIES MOTOR CROSS SECTION AND TABLE OF MATERIAL

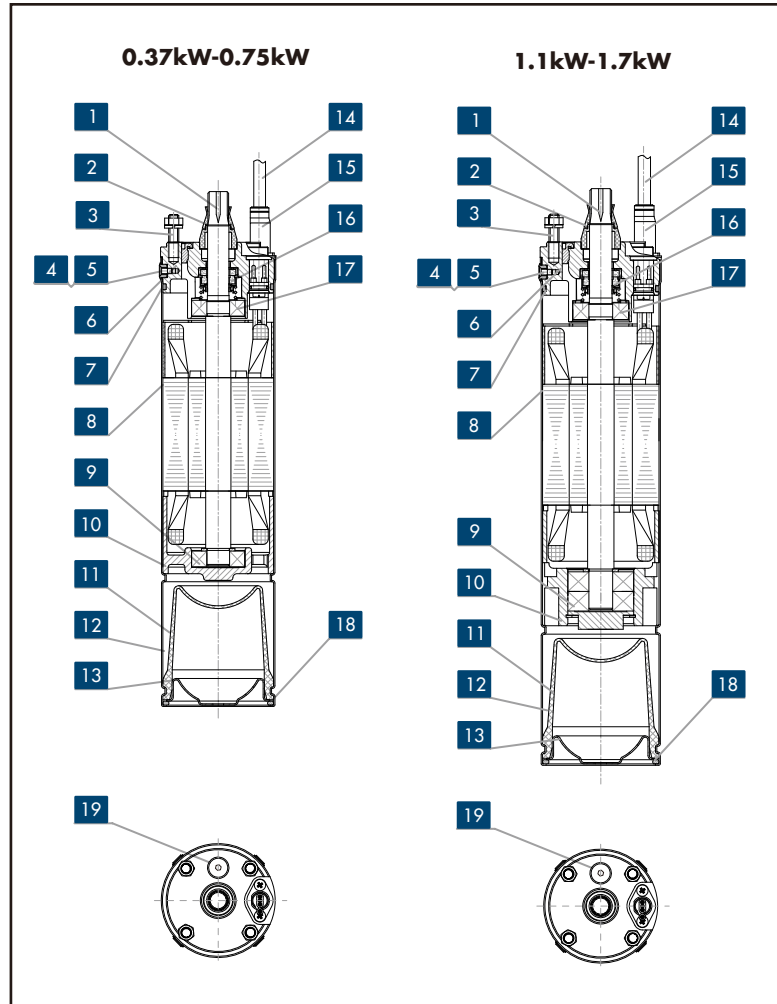

REF.N.	PART	MATERIAL	STANDARD
1	Shaft extension	Stainless steel	AISI 420
2	Sand protection	NBR	-----
3	Double ends studs	Stainless steel	AISI 201
4	Pin	Stainless steel	AISI 304
5	Screw	Stainless steel	AISI 201
6	Upper support	Cast iron & Stainless steel	ASTM 200A & AISI304
7	O-ring	NBR	-----
8	Motor shell	Stainless steel	AISI 201
9	Angular bearing	-----	-----
10	Lower support	Cast iron	ASTM 200A
11	Compensation bellow	NBR	-----
12	Cooling liquid	Non toxic oil	-----
13	Lower protection	Stainless steel	AISI 201
14	Cable	-----	-----
15	Cable connector sleeve	Stainless steel	AISI 201
16	Mechanical seal	Carbon/Ceramic	-----
17	Ball bearing	-----	-----
18	Snap ring	Stainless steel	AISI 201
19	Filling screw	Stainless steel	AISI 201

DIMENSIONS AND WEIGHTS AT 50 Hz

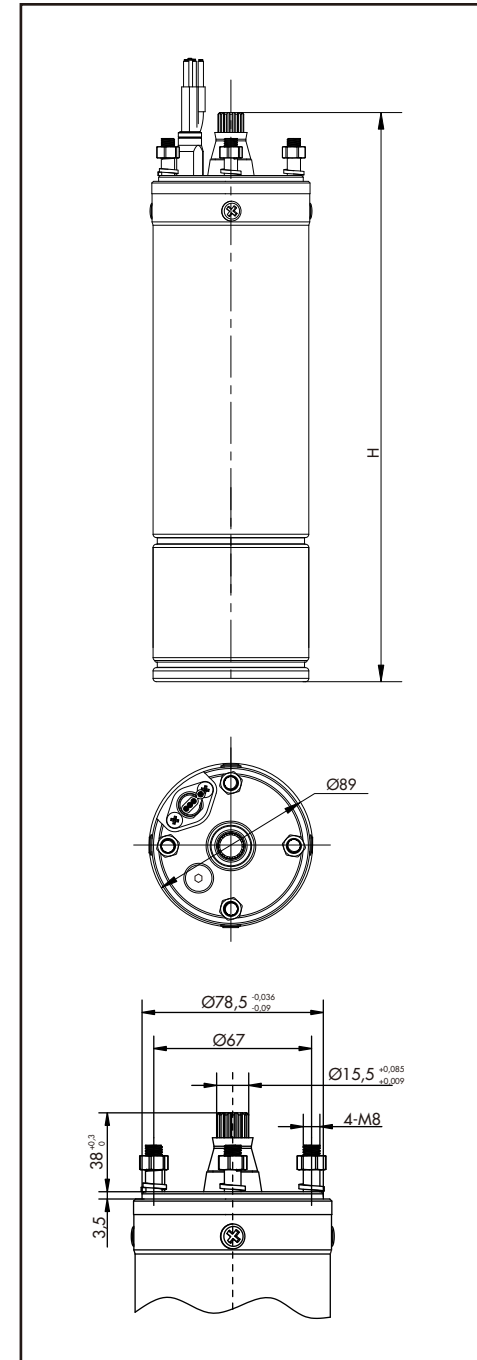

MOTOR TYPE	POWER		H mm	WEIGHT kg
	kW	Hp		
350S03S	0,37	0,5	450	7,9
350S05S	0,55	0,75	470	8,6
350S07S	0,75	1	503	9,4
350S09S	0,95	1,3	520	10,4
350S11S	1,1	1,5	548	11
350S15S	1,5	2	613	13
350S17S	1,7	2,3	640	13,6

YL-BG SERIES 3,5" SUBMERSIBLE ELECTRIC PUMPS

*COST-EFFECTIVE VERSION

- Cost-effective submersible electric pumps ensure low cost, high efficiency, better performance and reliability.

APPLICATIONS

- Water supply from deep well.
- Agricultural irrigation.
- Pressure boosting.
- Industrial application.

SPECIFICATIONS

- Delivery: up to 10,2 m³/h at 2850 rpm.
- Head: up to 160 m at 2850 rpm.
- Maximum pump overall diameter (cable cover included): 95 mm.
- Maximum permissible quantity of sand: 150 g/m³.
- Delivery port Rp 1" 1/2.

MOTOR

- 35OS single-phase version:
from 0,37 to 1,7 kW, 220 V, 50 Hz.
- Horizontal operation: 35OS up to 1,7 kW.
- Maximum temperature of water in contact with motor: 35°C .

CONSTRUCTION & CHARACTERISTICS

- Cost-effective construction ensures low cost, high efficiency, better performance and reliability.
- Abrasion resistant construction, floating impellers ensure optimum resistance to abrasion.
- The delivery port and suction support are made of precision-cast stainless steel, guarantee resistance to corrosion, durability and a sturdy coupling to the motor.
- The hexagonal pump shaft guarantees an effective impeller driving.
- A non-return valve is fitted at the discharge to prevent back flow of water and alleviate water hammer to the pump, safeguarding impellers and diffusers.
- The BG series pumps can be coupled with the 35OS motors.
- Vertical and horizontal installation .
- Standard and special versions available.

OPTIONAL FEATURES

- Different voltage and frequency.
- Different materials.



YL-BG SERIES

HYDRAULIC PERFORMANCE RANGE AT 50 Hz

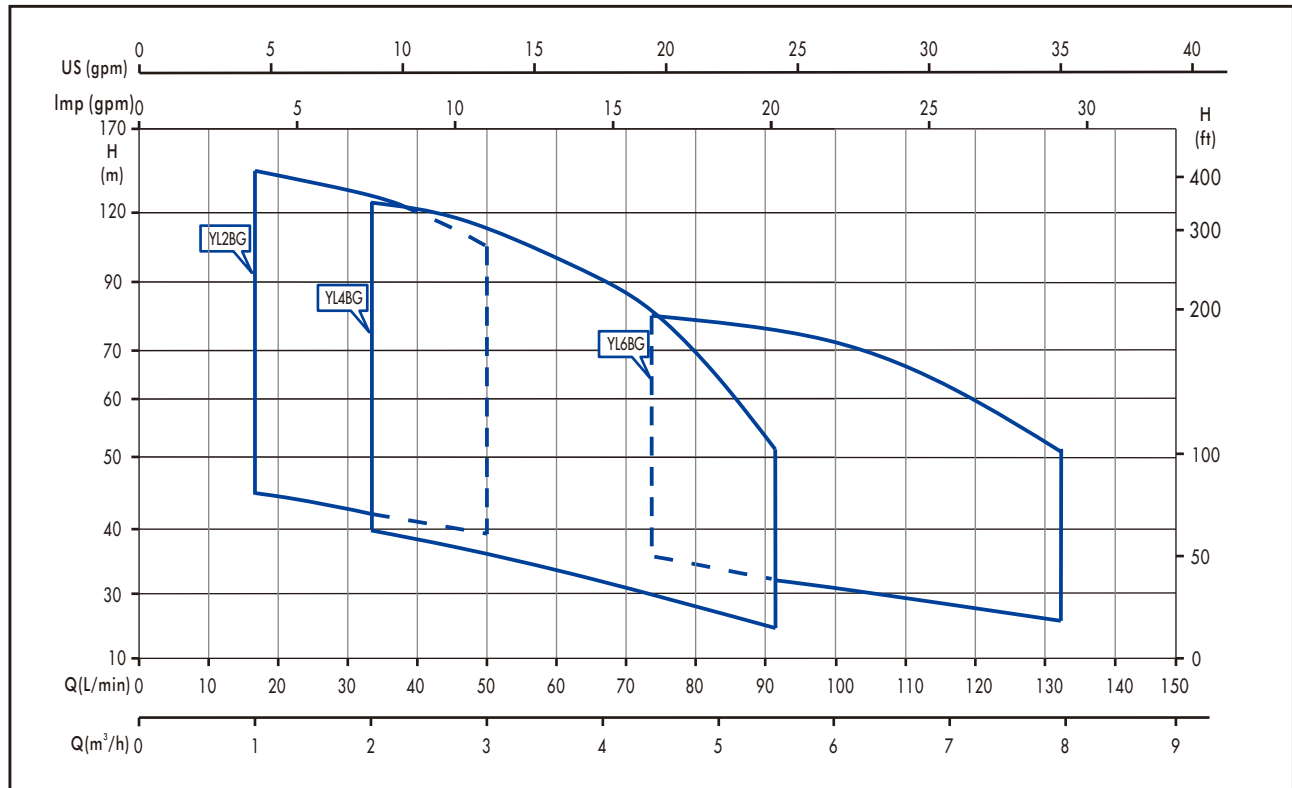

IDENTIFICATION CODE

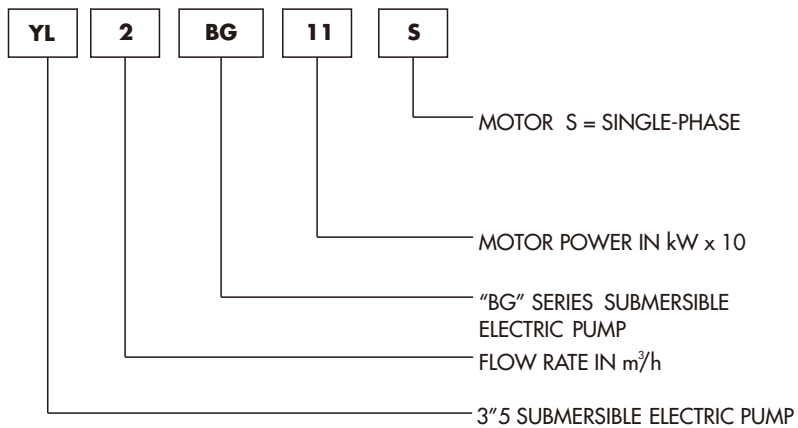

EXAMPLE OF PUMP TYPE

YL2BG11S

YL-BG series 3,5" submersible electric pump with flow rate of 2 m³/h and single-phase 1,1 kW (1,5 Hp) motor.



YL-2BG SERIES

PUMP SECTION AND LIST OF MAIN COMPONENTS MATERIAL

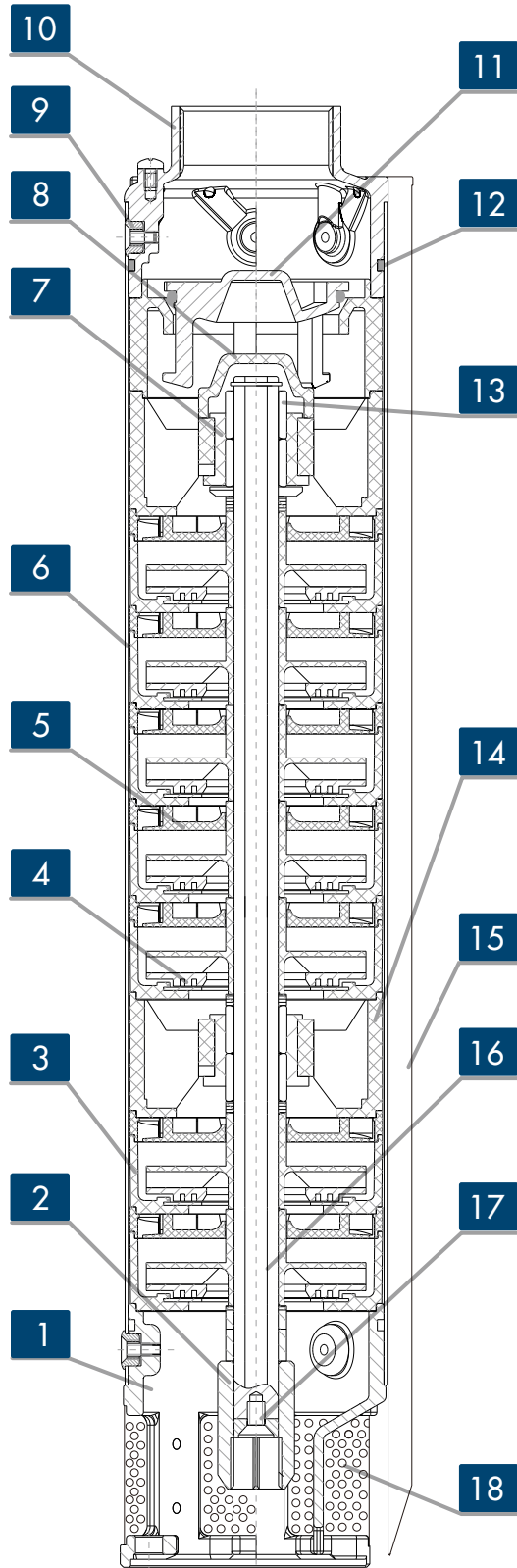

REF.N.	PART	MATERIAL	STANDARD
1	Lower support	Precision cast stainless steel & Cast iron	AISI 201 & ASTM 200A
2	Coupling	Stainless steel	AISI 304
3	Stage housing	ABS	-----
4	Impeller	ABS	-----
5	Diffuser	ABS	-----
6	Outer sleeve	Stainless steel	AISI 201
7	Bush bearing	TPU	-----
8	Sand protection cover	ABS	-----
9	Pin	Stainless steel	AISI 304
10	Delivery port	Precision cast stainless & Cast iron	AISI 201 & ASTM 200A
11	Non-return valve	PC	-----
12	O-ring	NBR	-----
13	Bushing	Stainless steel	AISI 304
14	Intermediate support	ABS	-----
15	Cable guard	Stainless steel	AISI 430
16	Shaft	Stainless steel	AISI 420
17	Screw	Stainless steel	AISI 201
18	Filter	Stainless steel	AISI 201

YL-4BG SERIES

PUMP SECTION AND LIST OF MAIN COMPONENTS MATERIAL

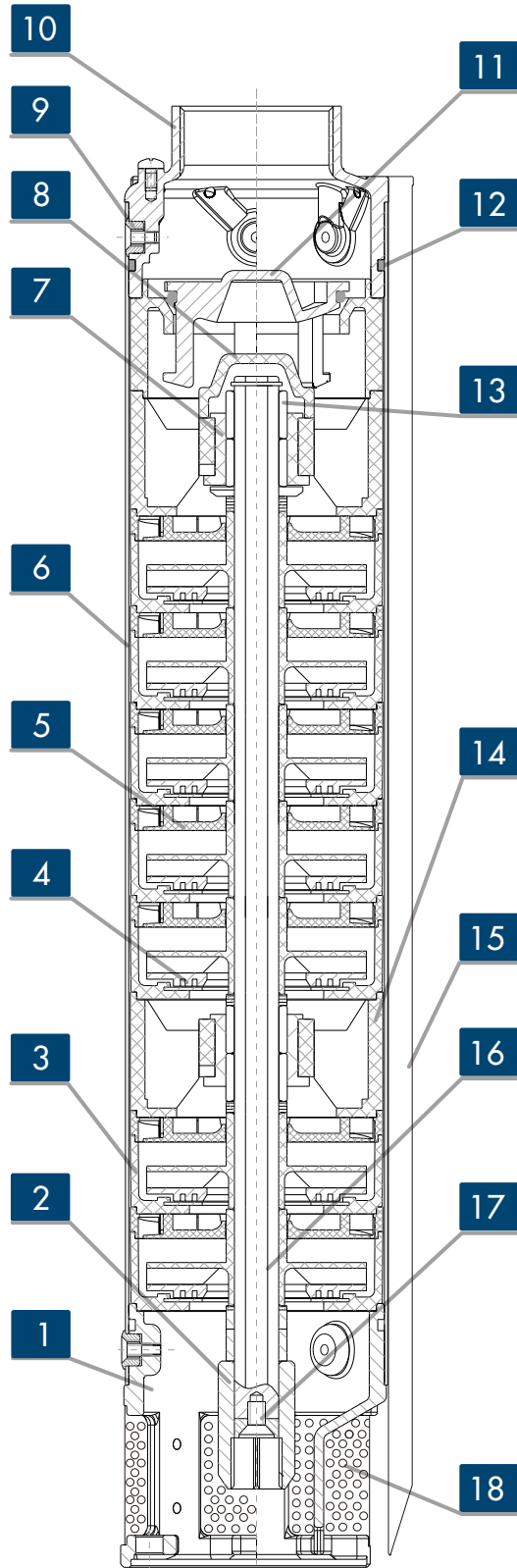

REF.N.	PART	MATERIAL	STANDARD
1	Lower support	Precision cast stainless steel & Cast iron	AISI 201 & ASTM 200A
2	Coupling	Stainless steel	AISI 304
3	Stage housing	ABS	-----
4	Impeller	ABS	-----
5	Diffuser	ABS	-----
6	Outer sleeve	Stainless steel	AISI 201
7	Bush bearing	TPU	-----
8	Sand protection cover	ABS	-----
9	Pin	Stainless steel	AISI 304
10	Delivery port	Precision cast stainless & Cast iron	AISI 201 & ASTM 200A
11	Non-return valve	PC	-----
12	O-ring	NBR	-----
13	Bushing	Stainless steel	AISI 304
14	Intermediate support	ABS	-----
15	Cable guard	Stainless steel	AISI 430
16	Shaft	Stainless steel	AISI 420
17	Screw	Stainless steel	AISI 201
18	Filter	Stainless steel	AISI 201

YL-6BG SERIES

PUMP SECTION AND LIST OF MAIN COMPONENTS MATERIAL

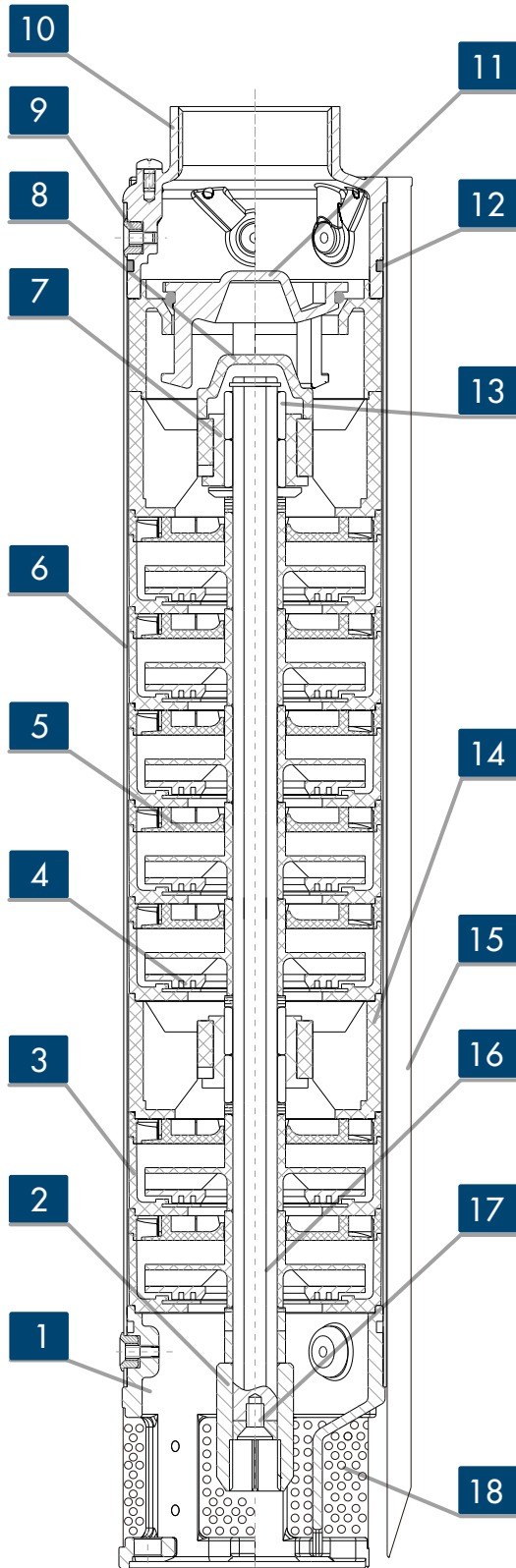

REF.N.	PART	MATERIAL	STANDARD
1	Lower support	Precision cast stainless steel & Cast iron	AISI 201 & ASTM 200A
2	Coupling	Stainless steel	AISI 304
3	Stage housing	ABS	-----
4	Impeller	ABS	-----
5	Diffuser	ABS	-----
6	Outer sleeve	Stainless steel	AISI 201
7	Bush bearing	TPU	-----
8	Sand protection cover	ABS	-----
9	Pin	Stainless steel	AISI 304
10	Delivery port	Precision cast stainless & Cast iron	AISI 201 & ASTM 200A
11	Non-return valve	PC	-----
12	O-ring	NBR	-----
13	Bushing	Stainless steel	AISI 304
14	Intermediate support	ABS	-----
15	Cable guard	Stainless steel	AISI 430
16	Shaft	Stainless steel	AISI 420
17	Screw	Stainless steel	AISI 201
18	Filter	Stainless steel	AISI 201

YL-2BG SERIES

OPERATING CHARACTERISTICS AT 50 Hz

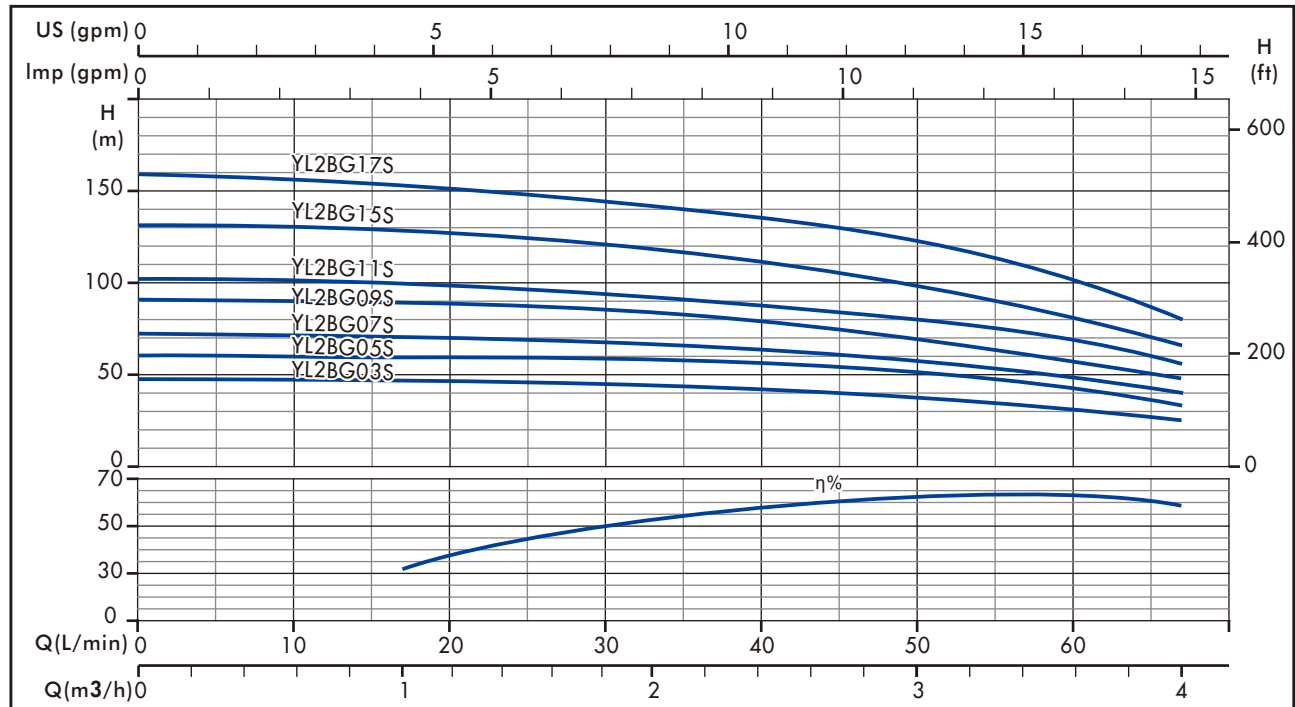

OPERATING CHARACTERISTICS AT 50 Hz

PUMP TYPE	No.OF STAGES	kW	Hp	Q=DELIVERY				
				l/min 0	17	33	50	67
				m³/h 0	1	2	3	4
H=TOTAL HEAD METERS COLUMN OF WATER								
YL2BG03S	8	0,37	0,5	48	47	42	39	26
YL2BG05S	10	0,55	0,75	60	59	55	49	33
YL2BG07S	12	0,75	1	72	71	66	57	40
YL2BG09S	15	0,95	1,3	89	88	82	70	49
YL2BG11S	17	1,1	1,5	102	100	93	80	56
YL2BG15S	22	1,5	2	131	127	120	99	67
YL2BG17S	27	1,7	2,3	160	153	140	115	78

DIMENSIONS AND WEIGHTS AT 50 Hz

PUMP TYPE	No.OF STAGES	DN	L1 mm	L mm	PUMP WEIGHT kg	ELECTRIC PUMP WEIGHT kg
YL2BG03S	8	Rp 1"1/2	398	807	3,4	11,3
YL2BG05S	10		453	882	3,7	12,3
YL2BG07S	12		508	970	4,0	13,4
YL2BG09S	15		591	1070	4,5	14,9
YL2BG11S	17		646	1153	5,1	16,1
YL2BG15S	22		840	1412	6,2	19,2
YL2BG17S	27		983	1582	7,5	21,1

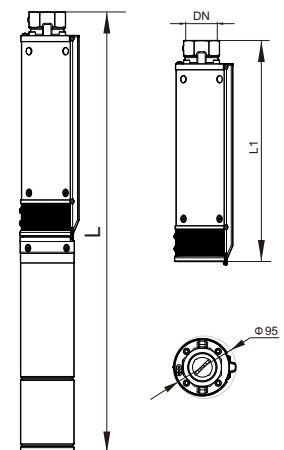

YL-4BG SERIES

OPERATING CHARACTERISTICS AT 50 Hz

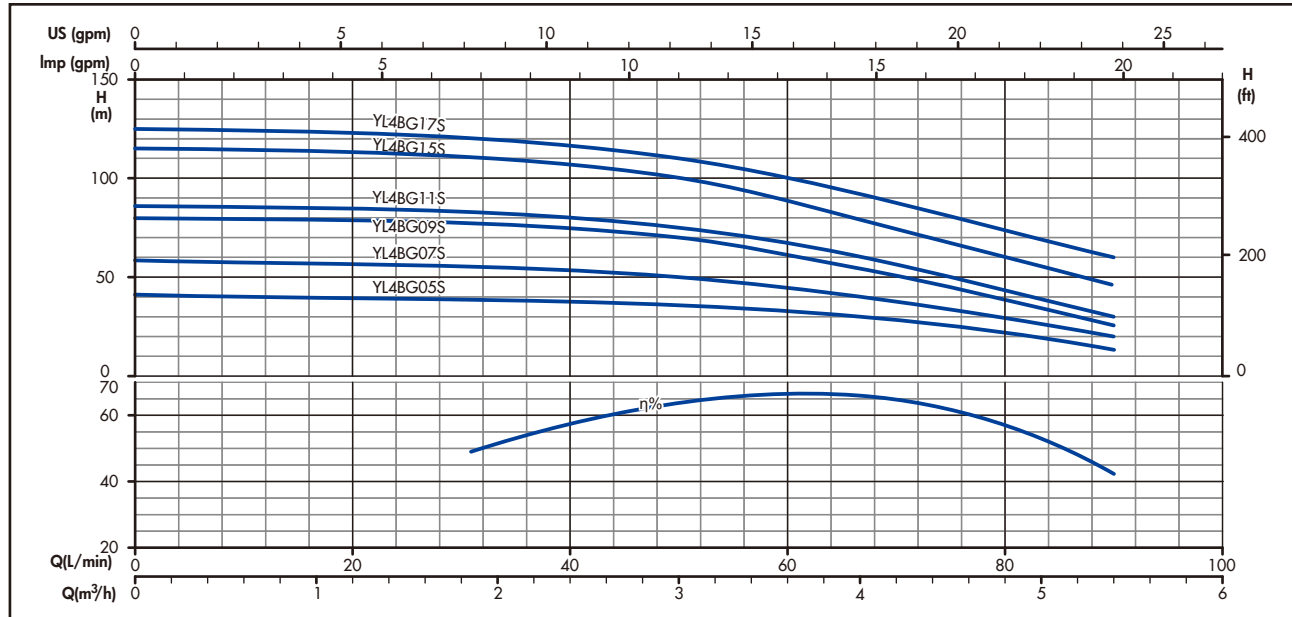

OPERATING CHARACTERISTICS AT 50 Hz

PUMP TYPE	No.OF STAGES	kW	Hp	Q=DELIVERY				
				l/min 0	17	50	67	100
				m³/h 0				
				1	3	4	6	
H=TOTAL HEAD METERS COLUMN OF WATER								
YL4BG05S	7	0,55	0,75	41	39	35	30	8
YL4BG07S	10	0,75	1	58	57	50	40	11
YL4BG09S	14	0,95	1,3	80	79	70	55	15
YL4BG11S	15	1,1	1,5	86	85	75	60	16
YL4BG15S	20	1,5	2	114	111	100	80	21
YL4BG17S	22	1,7	2,3	125	122	110	90	23

DIMENSIONS AND WEIGHTS AT 50 Hz

PUMP TYPE	No.OF STAGES	DN	L1 mm	L mm	PUMP WEIGHT kg	ELECTRIC PUMP WEIGHT kg
YL4BG05S	7	Rp 1"1/2	371	800	3,1	11,7
YL4BG07S	10		453	915	3,6	13
YL4BG09S	14		564	1043	4,2	14,6
YL4BG11S	15		591	1098	4,3	15,3
YL4BG15S	20		784	1356	5,6	18,6
YL4BG17S	22		839	1438	6,0	19,6

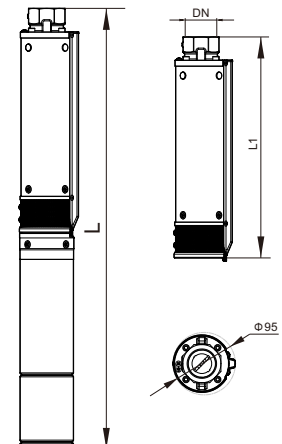

YL-6BG SERIES

OPERATING CHARACTERISTICS AT 50 Hz

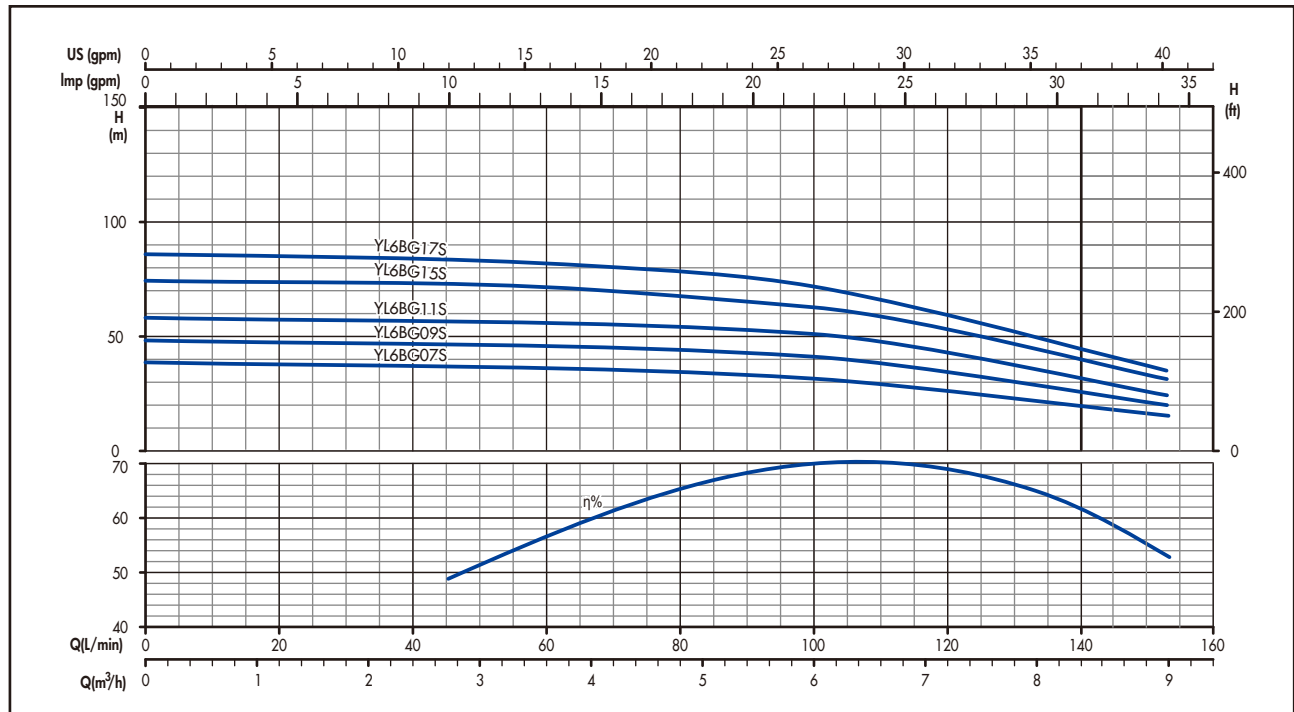

OPERATING CHARACTERISTICS AT 50 Hz

PUMP TYPE	No.OF STAGES	kW	Hp	Q=DELIVERY				
				l/min 0	67	100	133	150
				m ³ /h 0	4	6	8	9
H=TOTAL HEAD METERS COLUMN OF WATER								
YL6BG07S	7	0,75	1	38	35	32	21,5	15,5
YL6BG09S	9	0,95	1,3	48	45	40	28	20
YL6BG11S	11	1,1	1,5	59	55	50	34	24,5
YL6BG15S	13	1,5	2	75	70	63	43	31
YL6BG17S	15	1,7	2,3	86	80,5	72	49	36

DIMENSIONS AND WEIGHTS AT 50 Hz

PUMP TYPE	No.OF STAGES	DN	L1 mm	L mm	PUMP WEIGHT kg	ELECTRIC PUMP WEIGHT kg
YL6BG07S	7	Rp 1"1/2	419	881	2,8	12,2
YL6BG09S	9		490	969	3,2	13,6
YL6BG11S	11		560	1067	3,6	14,6
YL6BG15S	13		630	1202	4,2	17,2
YL6BG17S	15		699	1298	4,6	18,2

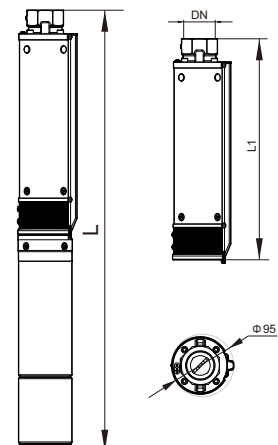

4OS SERIES 4" OIL-FILLED SUBMERSIBLE MOTORS

- The state-of-art design and choice of component materials ensure optimum operating performances, superior quality, reliability and ease of installation.

SPECIFICATIONS

- Shaft extension and couplings meet NEMA standards.
- Rewindable stator.
- Winding insulation: Class F .
- Protection grade: IP68.
- Filling fluid in compliance with standards concerning oils contact with foodstuffs and with the purity requirements specified by the annex to G.U. no. 104 of 20/04/1973; it also complies with F.D.A. (FOOD AND DRUG ADMINISTRATION) standards.
- Large compensation bellows for the expansion of the internal liquid.
- Oversized thrust bearings: Shaft supported by oversized angular bearings which can support thrust load up to 6500 N.
- Mechanical seal with sand protection.
- Removable cable connector.
- Maximum immersion depth: 150 m.
- Maximum number of starts per hour at regular intervals: 30 for direct start.
- Maximum allowable voltage fluctuations over the rated voltage:
 - 220 V \pm 10 %
 - 380 V \pm 10 %

MODELS

- Single-phase:
from 0,25 to 2,2 kW, 220 V, 50 Hz.
- Three-phase:
from 0,37 to 2,2 kW, 220 V, 50 Hz.
from 0,37 to 7,5 kW, 380 V, 50 Hz.

OPTIONAL FEATURES

- Different voltage and frequency.
- Different materials.



IDENTIFICATION CODE

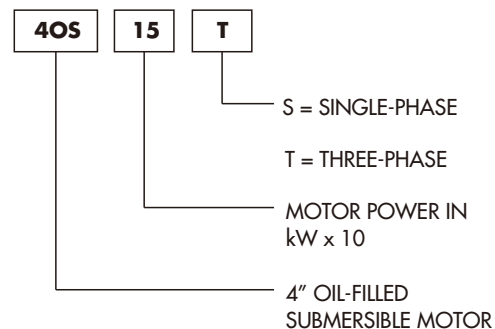

EXAMPLE OF MOTOR TYPE

4OS15T

4" oil-filled submersible motor, three-phase
1,5kW (2 Hp).

4OS SERIES MOTOR CROSS SECTION AND TABLE OF MATERIAL

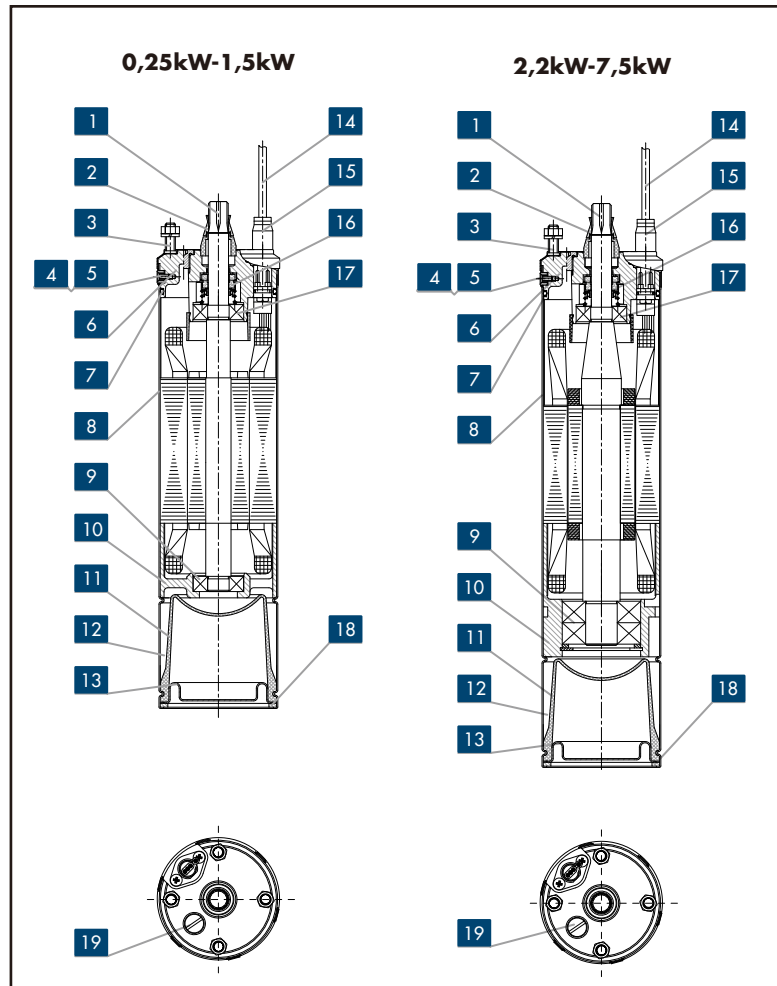

REF.N.	PART	MATERIAL	STANDARD
1	Shaft extension	Stainless steel	AIST 420(P≤1,5kW) AISI 630(2,2kW ≤ P ≤ 7,5kW)
2	Sand protection	NBR	-----
3	Double ends studs	Stainless steel	AISI 304
4	Pin	Stainless steel	AISI 304
5	Screw	Stainless steel	AISI 304
6	Upper support	Cast iron & Stainless steel/Brass	ASTM 200A & AISI304/ASTM 37700
7	O-ring	NBR	-----
8	Motor shell	Stainless steel	AISI 304
9	Angular bearing	-----	-----
10	Lower support	Cast iron	ASTM 200A
11	Compensation bellow	NBR	-----
12	Cooling liquid	Non toxic oil	-----
13	Lower protection	Stainless steel	AISI 304
14	Cable	-----	-----
15	Cable connector sleeve	Stainless steel	AISI 304
16	Mechanical seal	Carbon/Ceramic	-----
17	Ball bearing	-----	-----
18	Snap ring	Stainless steel	AISI 304
19	Filling screw	Stainless steel	AISI 304

DIMENSIONS AND WEIGHTS AT 50 Hz

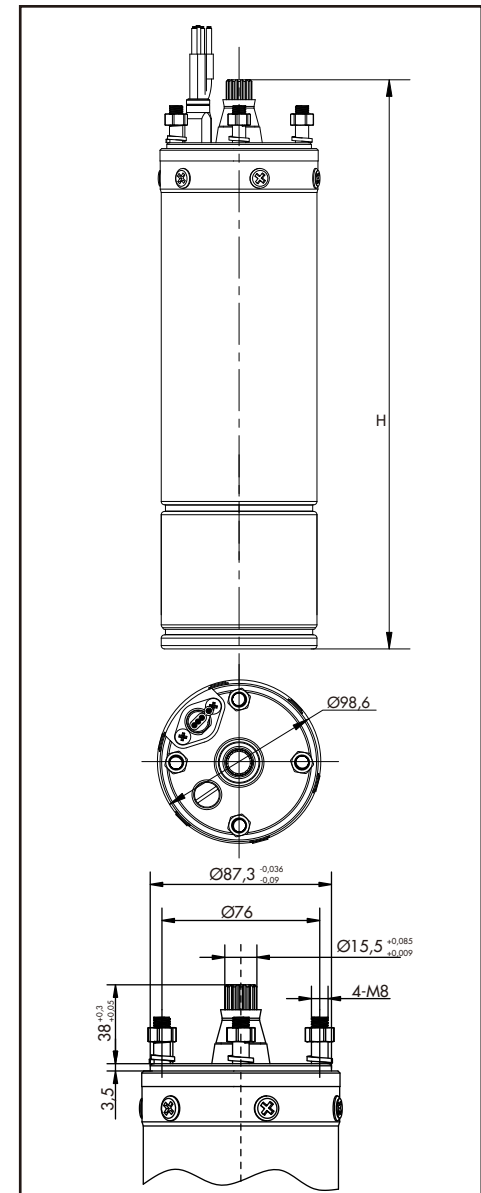

MOTOR TYPE	POWER		H mm	WEIGHT kg
	kW	Hp		
4OS02S	0,25	0,33	356,5	7,4
4OS03S	0,37	0,5	366,5	7,8
4OS03T			366,5	7,4
4OS05S	0,55	0,75	381,5	8,5
4OS05T			376,5	7,6
4OS07S	0,75	1	401,5	9,4
4OS07T			396,5	8,5
4OS11S	1,1	1,5	432,5	10,7
4OS11T			432,5	10
4OS15S	1,5	2	472,5	12,6
4OS15T			457,5	11,1
4OS22S	2,2	3	585	17,3
4OS22T			510	13,7
4OS30T	3	4	560	16
4OS40T	4	5,5	634	20,9
4OS55T	5,5	7,5	744	27,2
4OS75T	7,5	10	829	32,1

BH SERIES 4" SUBMERSIBLE ELECTRIC PUMPS



- State-of-art hydraulic design and the choice of best material ensure high efficiency, best performance and reliability.

APPLICATIONS

- Water supply from deep well.
- Agricultural irrigation.
- Pressure boosting.
- Fire-fighting.
- Industrial application.

SPECIFICATIONS

- Delivery: up to 22 m³/h at 2850 rpm.
- Head: up to 347 m at 2850 rpm.
- Maximum pump overall diameter (cable cover included): 99 mm.
- Maximum permissible quantity of sand: 150 g/m³.
- 1BH , 2BH , 3BH, 4BH , 6BH versions: delivery port Rp1"1/4.
- 8BH , 12BH , 16BH versions: delivery port Rp2" .

MOTOR

- 4OS single-phase version:
from 0,25 to 2,2 kW, 220 V, 50 Hz.
- 4OS three-phase version:
from 0,37 to 2,2 kW, 220 V, 50 Hz.
from 0,37 to 7,5 kW, 380 V, 50 Hz.
- Horizontal operation: 4OS up to 2,2 kW.
- Maximum temperature of water in contact with motor: 35 °C .

CONSTRUCTION & CHARACTERISTICS

- Easy to maintain and rapid to install.
- Abrasion resistant construction, floating impellers ensure optimum resistance to abrasion.
- The delivery port and suction support are made of precision-cast stainless steel, guarantee resistance to corrosion, durability and a sturdy coupling to the motor.
- The hexagonal pump shaft guarantees an effective impeller driving.
- A stainless steel non-return valve is fitted at the discharge to prevent back flow of water and alleviate water hammer to the pump, safeguarding impellers and diffusers.
- The BH series pumps can be coupled with the 4OS motors.
- Vertical and horizontal installation.
- Standard and special versions available.

OPTIONAL FEATURES

- Different voltage and frequency.
- Different materials.

BH SERIES

HYDRAULIC PERFORMANCE RANGE AT 50 Hz

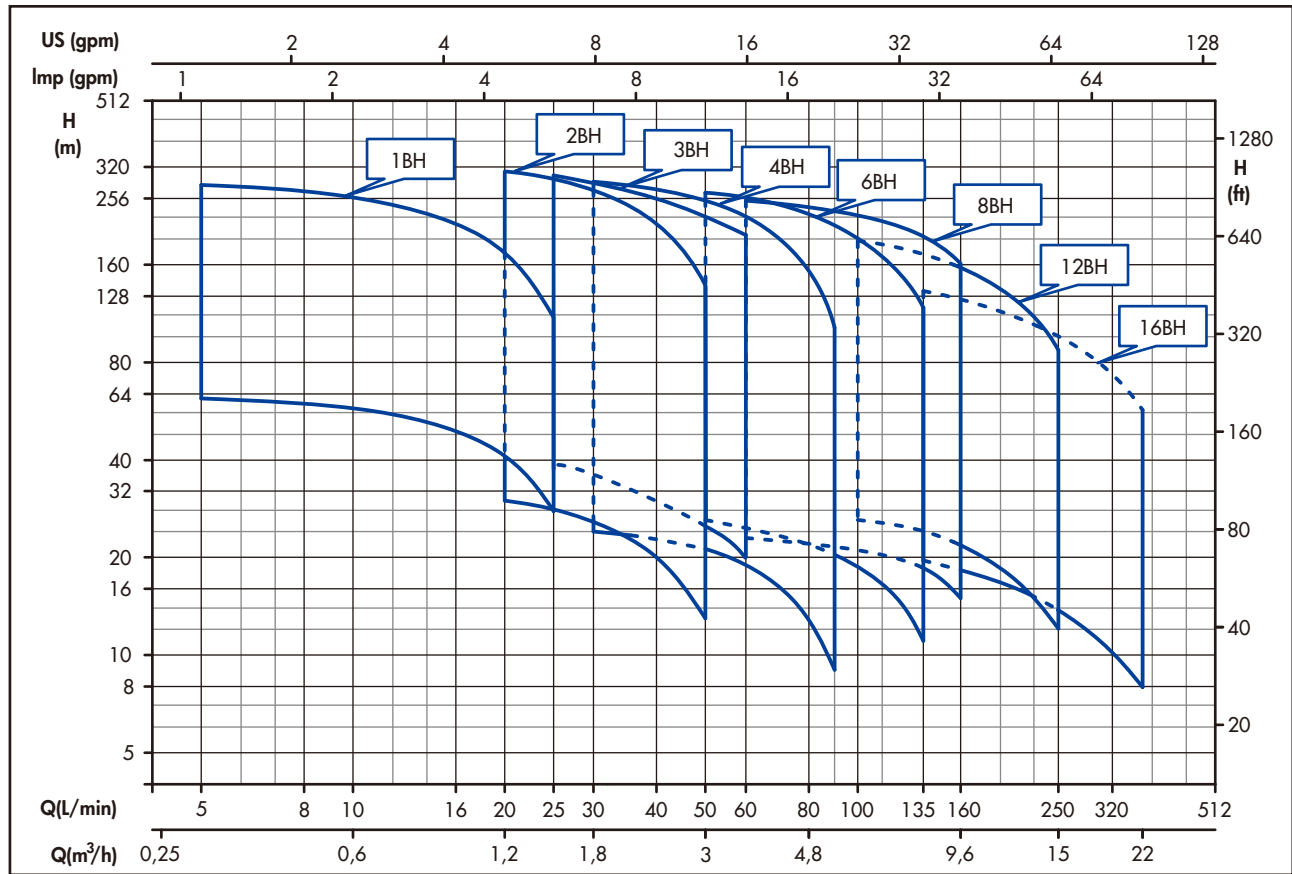

IDENTIFICATION CODE

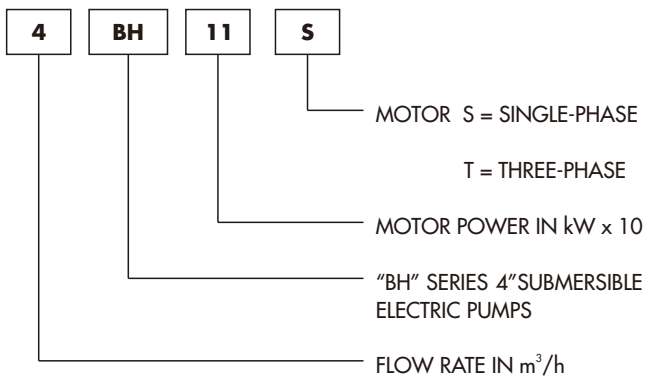

EXAMPLE OF PUMP TYPE

4BH11S

BH series 4" submersible electric pump with flow rate of 4 m^3/h ; and single-phase 1,1 kW (1,5 Hp) motor.



1BH-4BH SERIES

PUMP SECTION AND LIST OF MAIN COMPONENTS MATERIAL

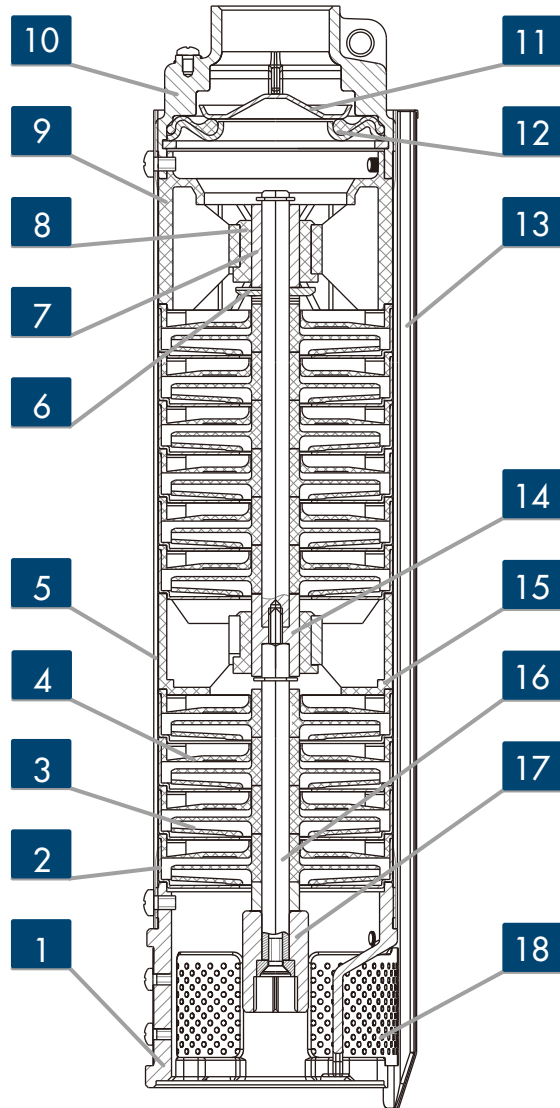

REF.N.	PART	MATERIAL	STANDARD
1	Lower support	Precision-cast stainless steel	AISI 304
2	Stage housing	Stainless steel	AISI 304
3	Impeller	Noryl® PPO	-----
4	Diffuser	Noryl® PPO	-----
5	Outer sleeve	Stainless steel	AISI 304
6	Thrust bearing	Stainless steel	AISI 304
7	Shaft sleeve	Stainless steel	AISI 304
8	Bush bearing	TPU	-----
9	Upper support	Noryl® PPO	-----
10	Delivery port	Precision-cast stainless steel	AISI 304
11	Non-return valve	Stainless steel	AISI 304
12	Valve support with gasket	Stainless steel & NBR	AISI 304& -----
13	Cable guard	Stainless steel	AISI 304
14	Intermediate shaft sleeve	Stainless steel	AISI 304
15	Intermediate support	Noryl® PPO	-----
16	Shaft	Stainless steel	AISI 420
17	Coupling	Stainless steel	AISI 304
18	Filter	Stainless steel	AISI 304

6BH-8BH SERIES

PUMP SECTION AND LIST OF MAIN COMPONENTS MATERIAL

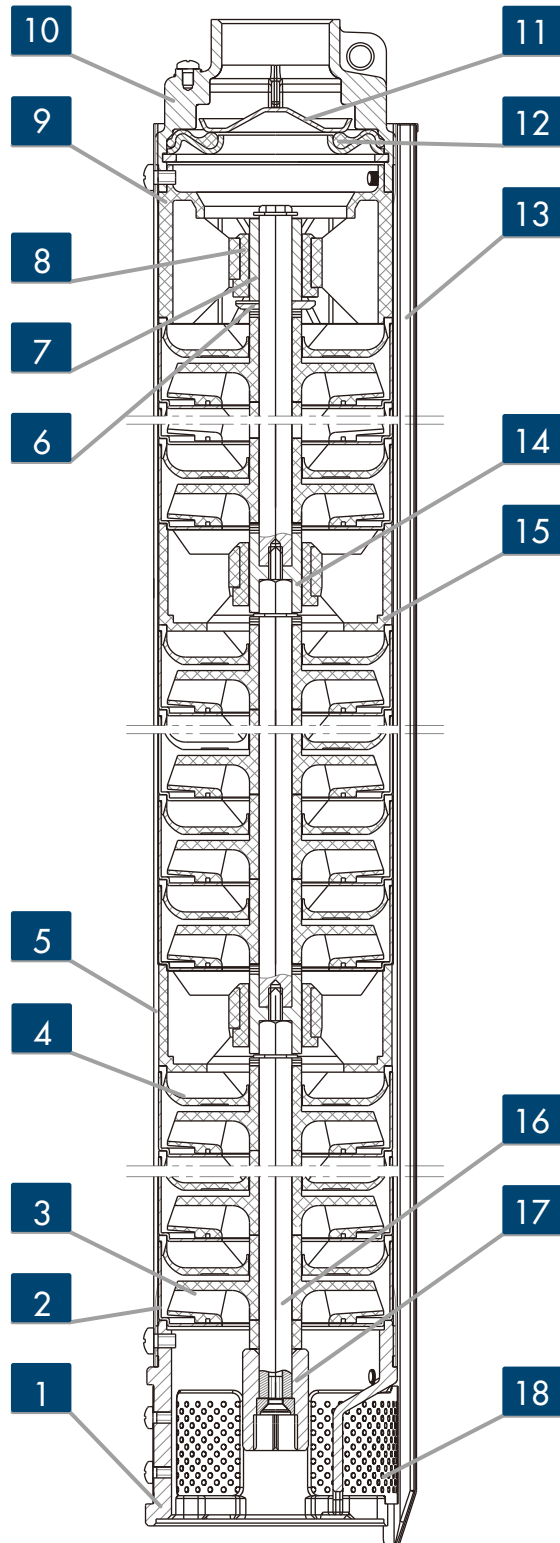

REF.N.	PART	MATERIAL	STANDARD
1	Lower support	Precision-cast stainless steel	AISI 304
2	Stage housing	Stainless steel	AISI 304
3	Impeller	Noryl® PPO	-----
4	Diffuser	Noryl® PPO	-----
5	Outer sleeve	Stainless steel	AISI 304
6	Thrust bearing	Stainless steel	AISI 304
7	Shaft sleeve	Stainless steel	AISI 304
8	Bush bearing	TPU	-----
9	Upper support	Noryl® PPO	-----
10	Delivery port	Precision-cast stainless steel	AISI 304
11	Non-return valve	Stainless steel	AISI 304
12	Valve support with gasket	Stainless steel & NBR	AISI 304 & -----
13	Cable guard	Stainless steel	AISI 304
14	Intermediate shaft sleeve	Stainless steel	AISI 304
15	Intermediate support	Noryl® PPO	-----
16	Shaft	Stainless steel	AISI 420
17	Coupling	Stainless steel	AISI 304
18	Filter	Stainless steel	AISI 304

12BH SERIES

PUMP SECTION AND LIST OF MAIN COMPONENTS MATERIAL

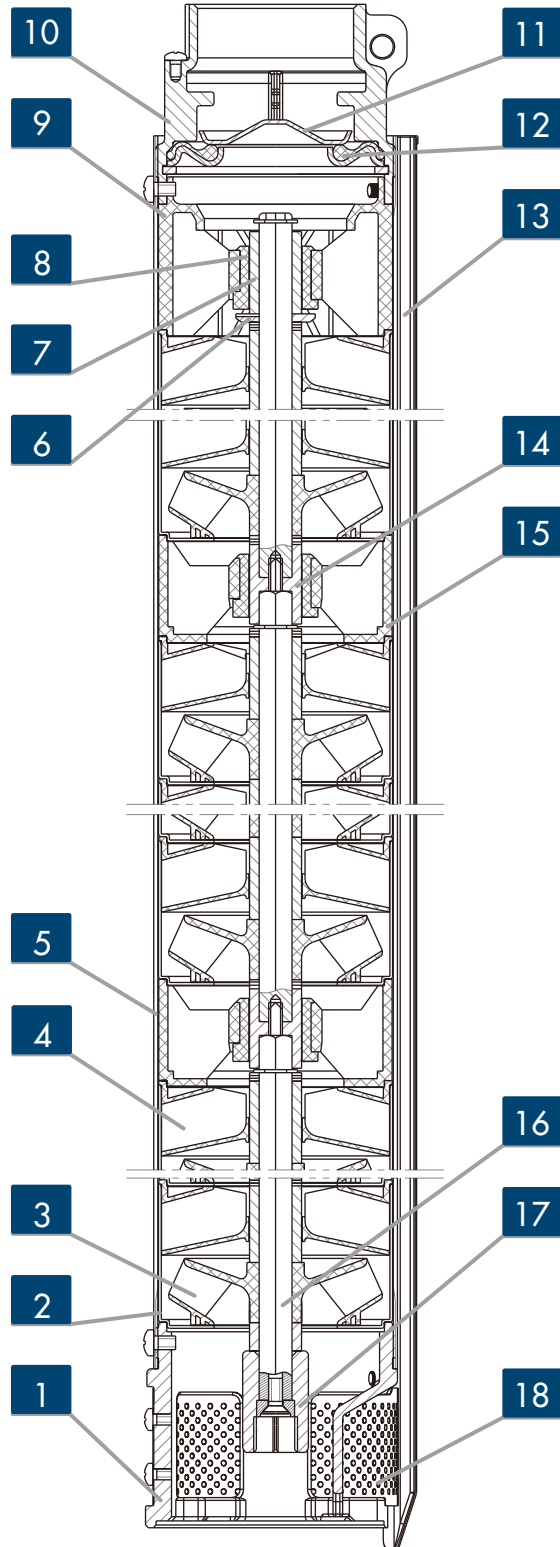

REF.N.	PART	MATERIAL	STANDARD
1	Lower support	Precision-cast stainless steel	AISI 304
2	Stage housing	Stainless steel	AISI 304
3	Impeller	Noryl® PPO	-----
4	Diffuser	Noryl® PPO	-----
5	Outer sleeve	Stainless steel	AISI 304
6	Thrust bearing	Stainless steel	AISI 304
7	Shaft sleeve	Stainless steel	AISI 304
8	Bush bearing	TPU	-----
9	Upper support	Noryl® PPO	-----
10	Delivery port	Precision-cast stainless steel	AISI 304
11	Non-return valve	Stainless steel	AISI 304
12	Valve support with gasket	Stainless steel & NBR	AISI 304 & -----
13	Cable guard	Stainless steel	AISI 304
14	Intermediate shaft sleeve	Stainless steel	AISI 304
15	Intermediate support	Noryl® PPO	-----
16	Shaft	Stainless steel	AISI 420
17	Coupling	Stainless steel	AISI 304
18	Filter	Stainless steel	AISI 304

16BH SERIES

PUMP SECTION AND LIST OF MAIN COMPONENTS MATERIAL

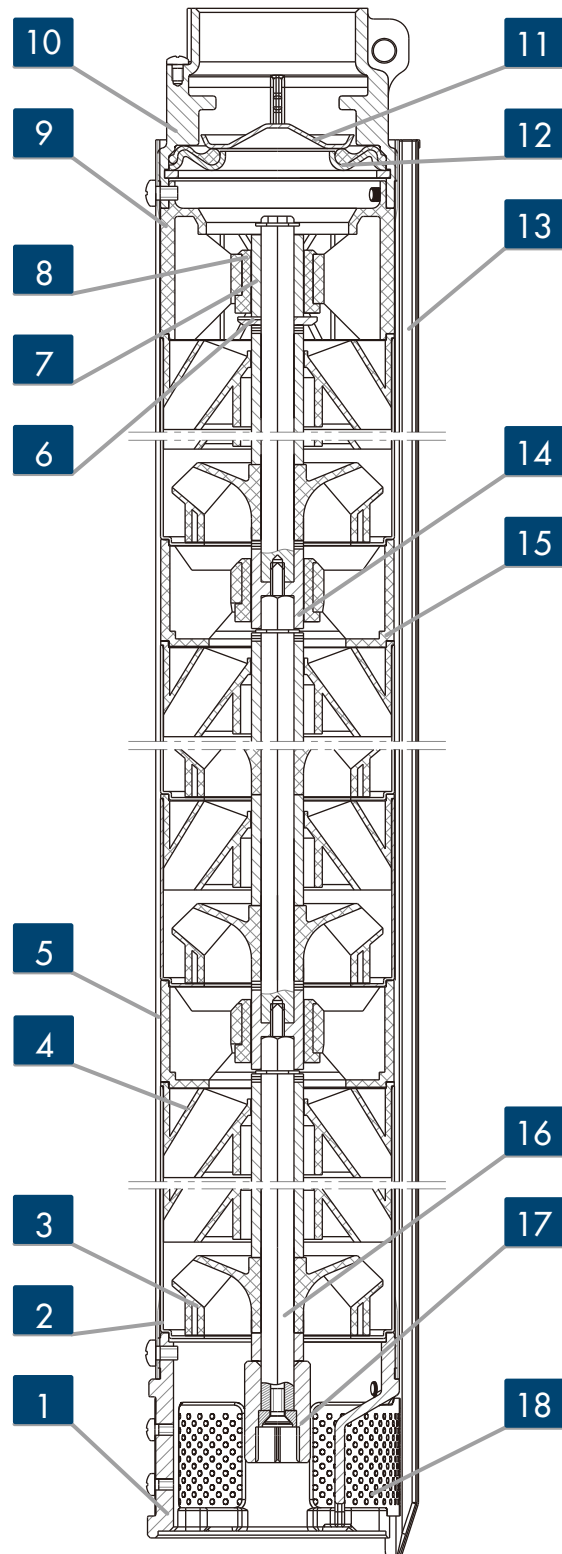

REF.N.	PART	MATERIAL	STANDARD
1	Lower support	Precision-cast stainless steel	AISI 304
2	Stage housing	Stainless steel	AISI 304
3	Impeller	Noryl® PPO	-----
4	Diffuser	Noryl® PPO	-----
5	Outer sleeve	Stainless steel	AISI 304
6	Thrust bearing	Stainless steel	AISI 304
7	Shaft sleeve	Stainless steel	AISI 304
8	Bush bearing	TPU	-----
9	Upper support	Noryl® PPO	-----
10	Delivery port	Precision-cast stainless steel	AISI 304
11	Non-return valve	Stainless steel	AISI 304
12	Valve support with gasket	Stainless steel & NBR	AISI 304& -----
13	Cable guard	Stainless steel	AISI 304
14	Intermediate shaft sleeve	Stainless steel	AISI 304
15	Intermediate support	Noryl® PPO	-----
16	Shaft	Stainless steel	AISI 420
17	Coupling	Stainless steel	AISI 304
18	Filter	Stainless steel	AISI 304

1BH SERIES

OPERATING CHARACTERISTICS AT 50 Hz

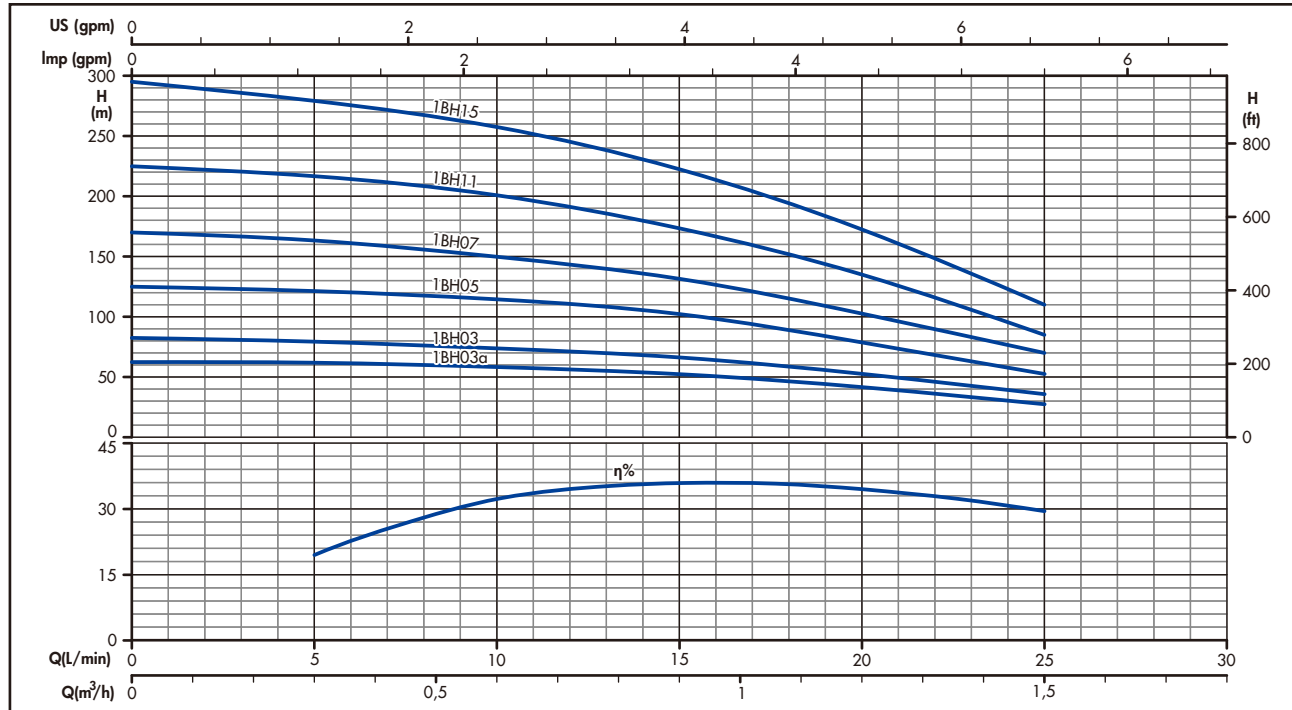

OPERATING CHARACTERISTICS AT 50 Hz

PUMP TYPE	No. OF STAGES	kW	Hp	Q=DELIVERY					
				l/min 0	5	10	15	20	25
				m³/h 0 0,3 0,6 0,9 1,2 1,5					
				H=TOTAL HEAD METERS COLUMN OF WATER					
1BH03Sa	10	0,37	0,5	64	62	57	52	40	28
1BH03S	13	0,37	0,5	82	80	73	68	52	36
1BH03T									
1BH05S	19	0,55	0,75	125	120	110	102	76	54
1BH05T									
1BH07S	26	0,75	1	169	163	149	131	100	70
1BH07T									
1BH11S	37	1,1	1,5	225	218	200	172	135	85
1BH11T									
1BH15S	48	1,5	2	291	282	259	223	175	110
1BH15T									

DIMENSIONS AND WEIGHTS AT 50 Hz

PUMP TYPE	No. OF STAGES	DN	L1 mm	L mm	PUMP WEIGHT kg	ELECTRIC PUMP WEIGHT kg
1BH03Sa	10	Rp1"1/4	321	647	3,5	11,7
1BH03S	13		367	693	4	12,2
1BH03T			367	693		11,8
1BH05S	19		460	801	5,1	14
1BH05T			460	796		13,1
1BH07S	26		567	928	6,4	16,2
1BH07T			567	923		15,3
1BH11S	37		774	1166	8,6	19,7
1BH11T			774	1166		19
1BH15S	48		943	1375	10,6	23,6
1BH15T			943	1360		22,1

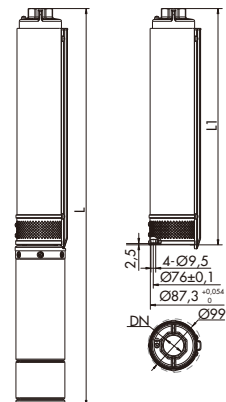

2BH SERIES

OPERATING CHARACTERISTICS AT 50 Hz

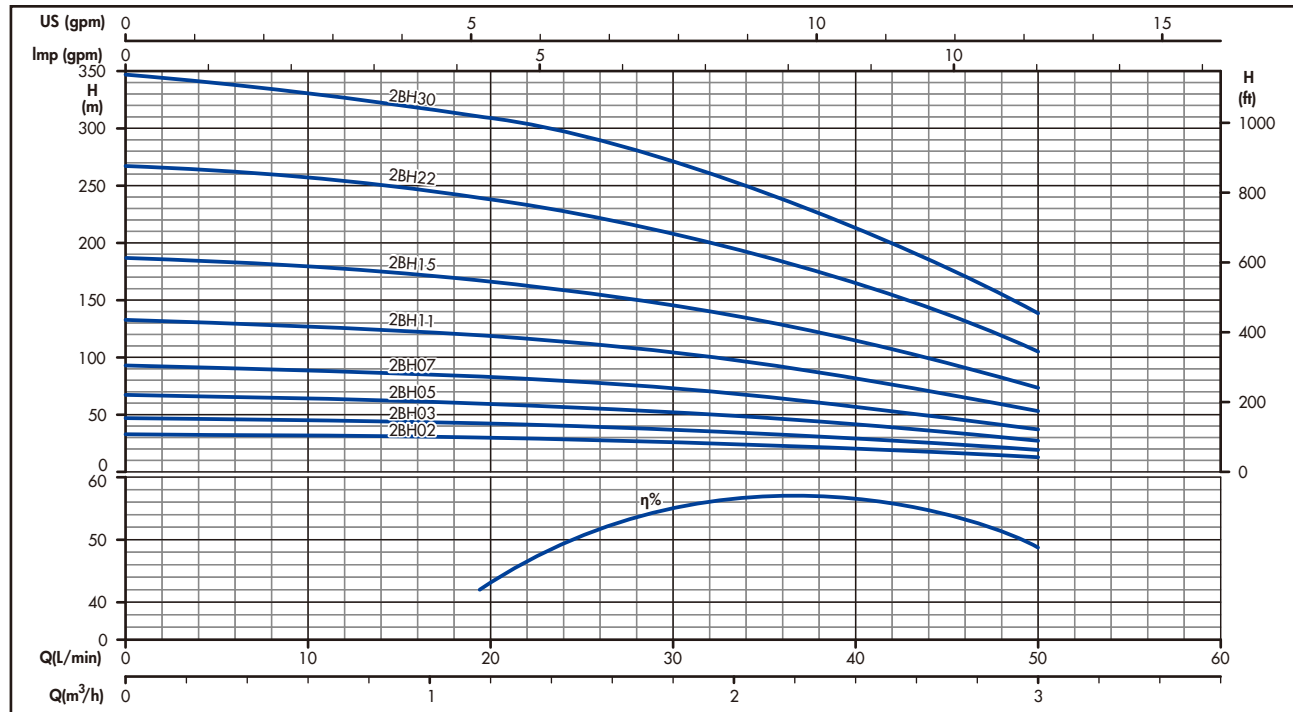

OPERATING CHARACTERISTICS AT 50 Hz

PUMP TYPE	No.OF STAGES	kW	Hp	Q=DELIVERY					
				l/min 0	20	25	30	40	50
				m³/h 0					
				1,2	1,5	1,8	2,4	3	
				H=TOTAL HEAD METERS COLUMN OF WATER					
2BH02S	5	0,25	0,33	33	30	28	26	20	13
2BH03S	7	0,37	0,5	47	42	40	36	29	19
2BH03T									
2BH05S	10	0,55	0,75	67	60	56	52	41	27
2BH05T									
2BH07S	14	0,75	1	93	83	79	73	57	37
2BH07T									
2BH11S	20	1,1	1,5	133	119	113	104	82	53
2BH11T									
2BH15S	28	1,5	2	187	167	158	146	115	74
2BH15T									
2BH22S	40	2,2	3	267	238	226	208	164	106
2BH22T									
2BH30T	52	3	4	347	309	294	271	213	138

DIMENSIONS AND WEIGHTS AT 50 Hz

PUMP TYPE	No.OF STAGES	DN	L1 mm	L mm	PUMP WEIGHT kg	ELECTRIC PUMP WEIGHT kg
2BH02S	5	Rp1"1/4	258	574	2,3	10,1
2BH03S	7		294	620	2,7	10,9
2BH03T				620		10,5
2BH05S	10		348	689	3,2	12,1
2BH05T				684		11,2
2BH07S	14		421	782	3,9	13,7
2BH07T				777		12,8
2BH11S	20		529	921	5	16,1
2BH11T				921		15,4
2BH15S	28		673	1105	6,4	19,4
2BH15T				1090		17,9
2BH22S	40		927	1472	9,1	26,8
2BH22T				1397		23,2
2BH30T	52		1143	1663	11,2	27,7

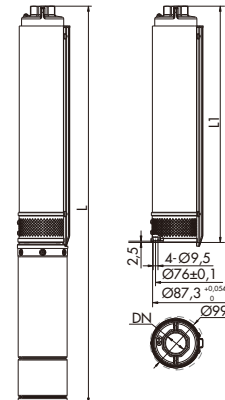

3BH SERIES

OPERATING CHARACTERISTICS AT 50 Hz

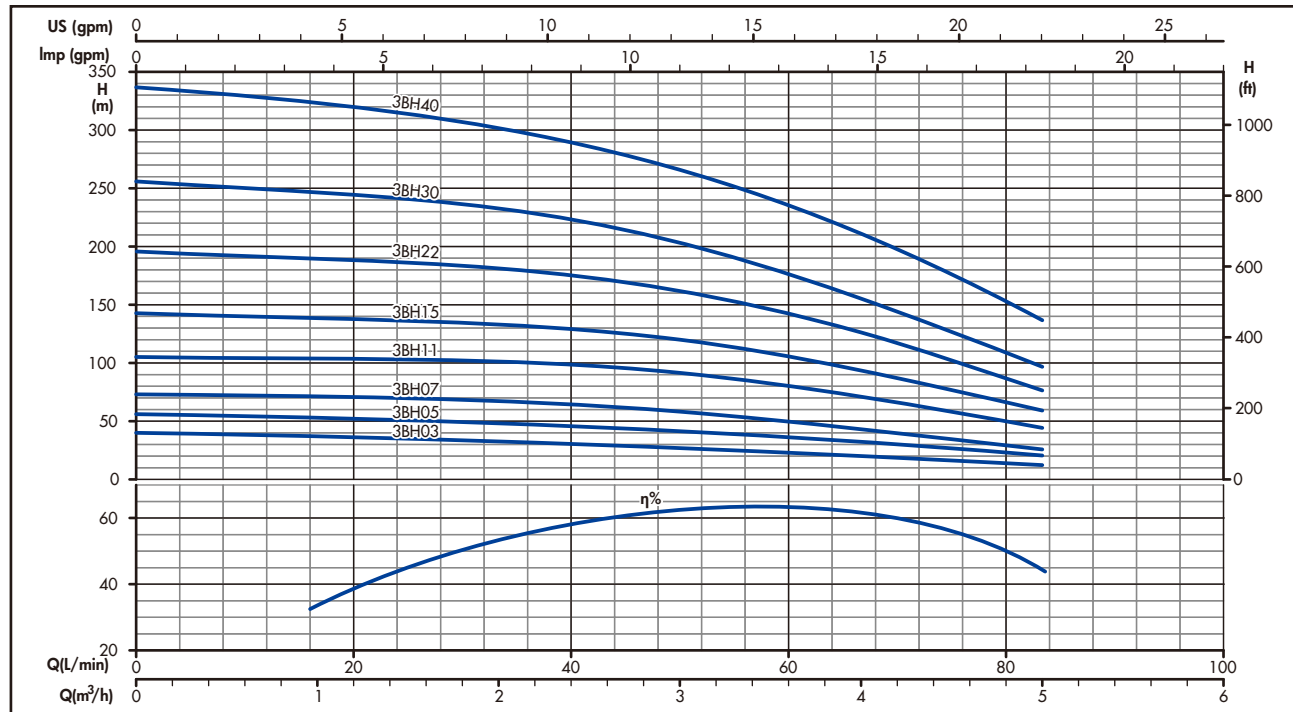

OPERATING CHARACTERISTICS AT 50 Hz

PUMP TYPE	No. OF STAGES	kW	Hp	Q=DELIVERY					
				l/min 0	17	33	50	67	84
				m³/h 0	1	2	3	4	5
H=TOTAL HEAD METERS COLUMN OF WATER									
3BH03S	6	0,37	0,5	40	39	37	33	25	15
3BH03T									
3BH05S	8	0,55	0,75	53	52	50	43	33	19
3BH05T									
3BH07S	11	0,75	1	72	71	67	59	44	24
3BH07T									
3BH11S	16	1,1	1,5	108	107	103	90	69	43
3BH11T									
3BH15S	21	1,5	2	142	141	136	121	96	63
3BH15T									
3BH22S	30	2,2	3	196	195	185	164	126	78
3BH22T									
3BH30T	40	3	4	253	251	237	208	155	87
3BH40T	53	4	5,5	337	335	317	278	212	126

DIMENSIONS AND WEIGHTS AT 50 Hz

PUMP TYPE	No. OF STAGES	DN	L1 mm	L mm	PUMP WEIGHT kg	ELECTRIC PUMP WEIGHT kg
3BH03S	6	Rp1"1/4	298	624	2,7	10,9
3BH03T				624		10,5
3BH05S	8		341	682	3,2	12,1
3BH05T				677		11,2
3BH07S	11		406	767	4	13,8
3BH07T				762		12,9
3BH11S	16		515	907	4,9	16
3BH11T				907		15,3
3BH15S	21		623	1055	5,9	18,9
3BH15T				1040		17,4
3BH22S	30		855	1400	8,1	25,8
3BH22T				1325		22,2
3BH30T	40		1072	1592	10,3	26,8
3BH40T	53		1355	1949	12,9	33,3

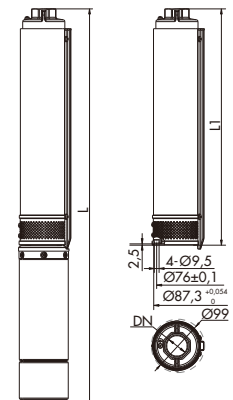

4BH SERIES

OPERATING CHARACTERISTICS AT 50 Hz

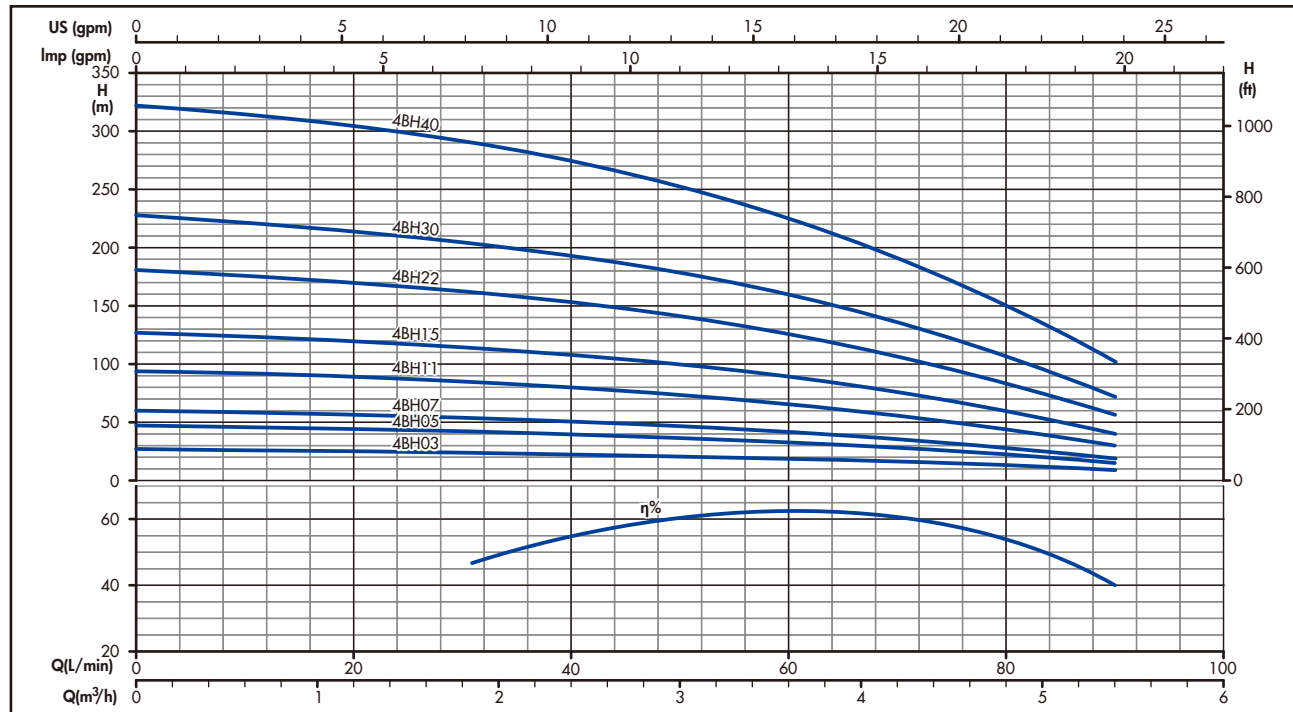

OPERATING CHARACTERISTICS AT 50 Hz

PUMP TYPE	No.OF STAGES	kW	Hp	Q=DELIVERY						
				l/min 0	30	40	50	60	80	90
				H=TOTAL HEAD METERS COLUMN OF WATER						
4BH03S	4	0,37	0,5	27	24	23	21	19	13	9
4BH03T				27	24	23	21	19	13	9
4BH05S	7	0,55	0,75	47	42	40	37	33	22	15
4BH05T				47	42	40	37	33	22	15
4BH07S	9	0,75	1	60	54	51	47	42	28	19
4BH07T				60	54	51	47	42	28	19
4BH11S	14	1,1	1,5	94	84	80	74	66	44	30
4BH11T				94	84	80	74	66	44	30
4BH15S	19	1,5	2	127	114	108	100	89	60	40
4BH15T				127	114	108	100	89	60	40
4BH22S	27	2,2	3	181	162	154	142	127	85	57
4BH22T				181	162	154	142	127	85	57
4BH30T	35	3	4	228	204	194	179	160	107	72
4BH40T	48	4	5,5	322	288	274	252	226	151	102

DIMENSIONS AND WEIGHTS AT 50 Hz

PUMP TYPE	No.OF STAGES	DN	L1 mm	L mm	PUMP WEIGHT kg	ELECTRIC PUMP WEIGHT kg
4BH03S	4	Rp1"1/4	254	580	2,2	10,4
4BH03T				580		10
4BH05S	7		319	660	2,8	11,7
4BH05T				655		10,8
4BH07S	9		362	723	3,2	13
4BH07T				718		12,1
4BH11S	14		471	863	4,2	15,3
4BH11T				863		14,6
4BH15S	19		579	1011	5,2	18,2
4BH15T				996		16,7
4BH22S	27		790	1335	7,4	25,1
4BH22T				1260		21,5
4BH30T	35		964	1484	9	25,5
4BH40T	48		1246	1840	11,6	33

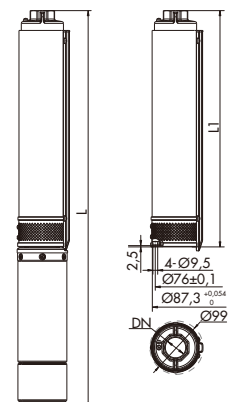

6BH SERIES

OPERATING CHARACTERISTICS AT 50 Hz

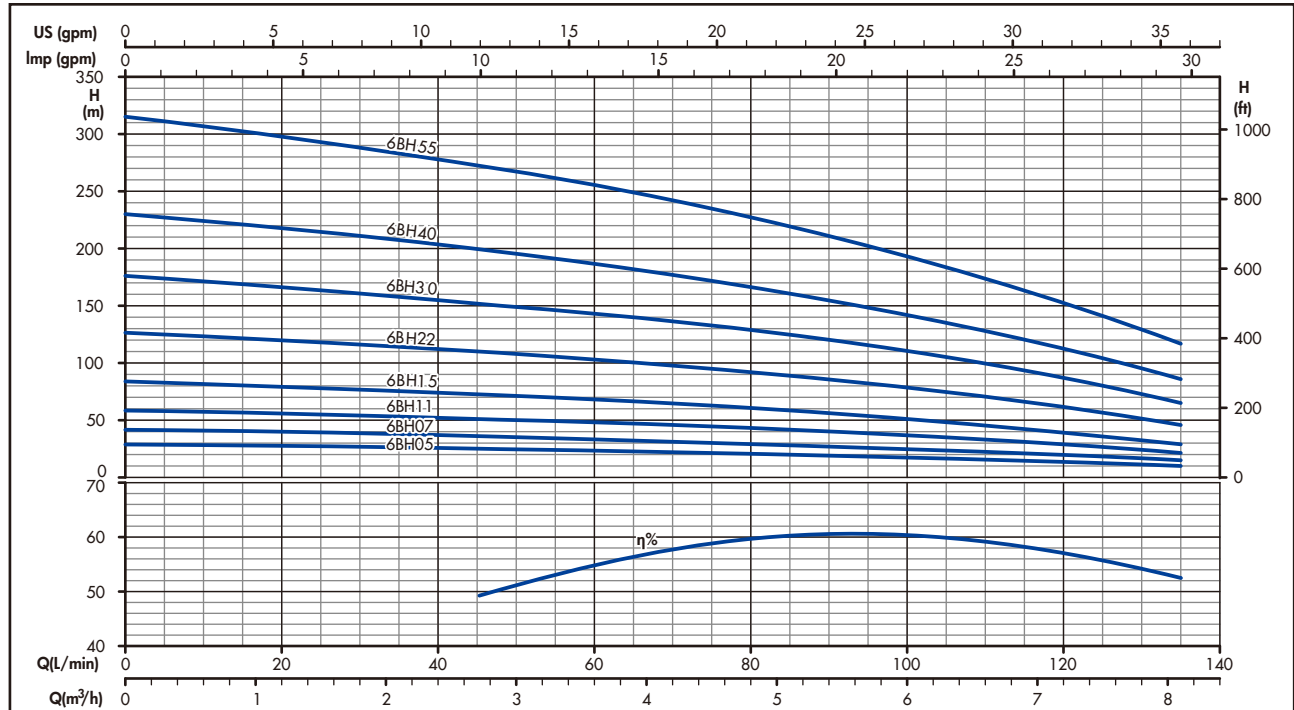

OPERATING CHARACTERISTICS AT 50 Hz

PUMP TYPE	No.OF STAGES	kW	Hp	Q=DELIVERY						
				l/min 0	60	75	90	105	120	135
				m ³ /h 0						
				3,6	4,5	5,4	6,3	7,2	8,1	
				H=TOTAL HEAD METERS COLUMN OF WATER						
6BH05S	5	0,55	0,75	30	25	23	20	18	15	11
6BH05T										
6BH07S	7	0,75	1	43	35	32	28	24	20	15
6BH07T										
6BH11S	10	1,1	1,5	61	49	46	41	35	30	22
6BH11T										
6BH15S	14	1,5	2	85	69	64	57	50	41	31
6BH15T										
6BH22S	21	2,2	3	128	104	97	87	76	61	47
6BH22T										
6BH30T	29	3	4	177	143	132	119	105	85	66
6BH40T	38	4	5,5	232	188	172	156	136	112	86
6BH55T	52	5,5	7,5	317	257	235	213	185	152	118

DIMENSIONS AND WEIGHTS AT 50 Hz

PUMP TYPE	No.OF STAGES	DN	L1 mm	L mm	PUMP WEIGHT kg	ELECTRIC PUMP WEIGHT kg
6BH05S	5	Rp1"1/4	322	663	2,8	11,7
6BH05T				658		10,8
6BH07S	7		384	745	3,4	13,2
6BH07T				740		12,3
6BH11S	10		477	869	4,2	15,3
6BH11T				869		14,6
6BH15S	14		601	1033	5,2	18,2
6BH15T				1018		16,7
6BH22S	21		856	1401	7,6	25,3
6BH22T				1326		21,7
6BH30T	29		1104	1624	9,7	26,2
6BH40T	38		1383	1977	12,1	33,5
6BH55T	52		1854	2558	16,3	44

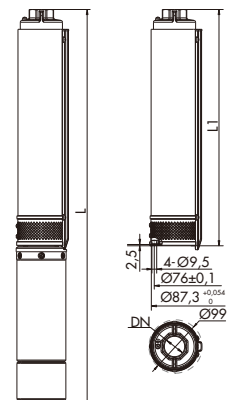

8BH SERIES

OPERATING CHARACTERISTICS AT 50 Hz

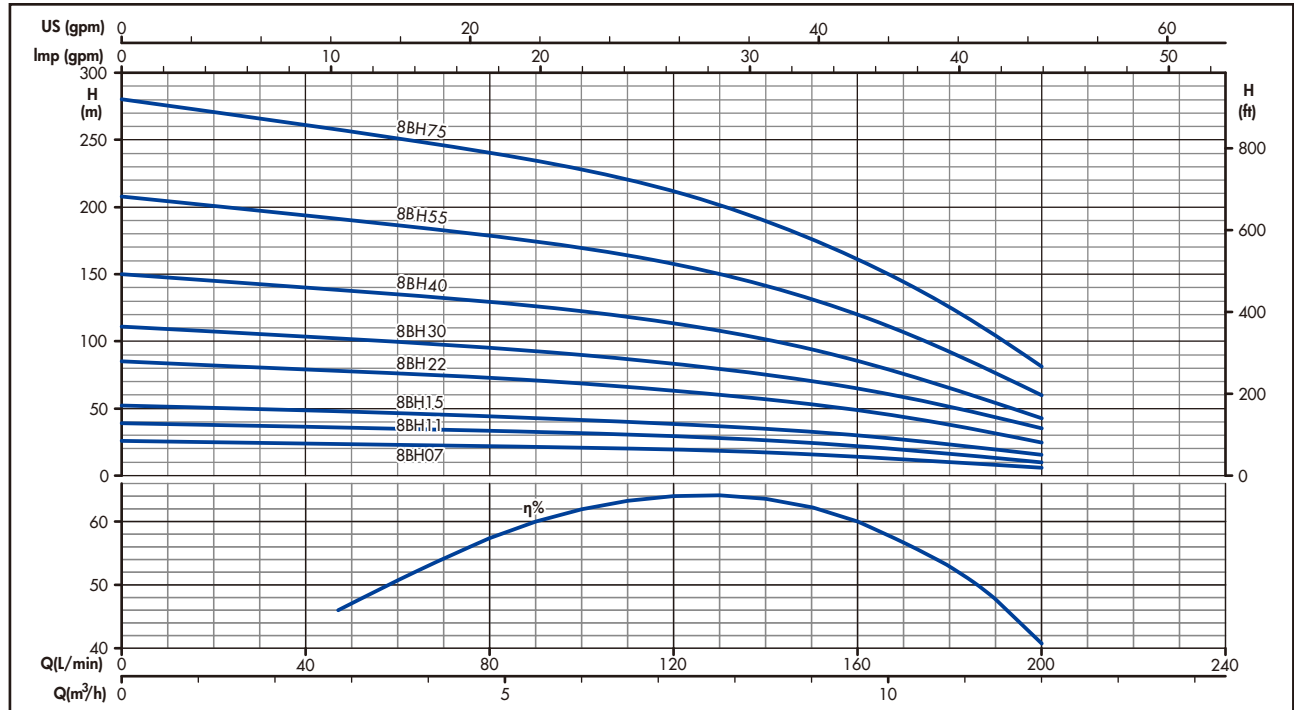

OPERATING CHARACTERISTICS AT 50 Hz

PUMP TYPE	No.OF STAGES	kW	Hp	Q=DELIVERY					
				l/min 0	40	80	120	160	200
				m ³ /h 0	2,4	4,8	7,2	9,6	12
				H=TOTAL HEAD METERS COLUMN OF WATER					
8BH07S	4	0,75	1	26	24	22	20	15	6
8BH07T									
8BH11S	6	1,1	1,5	39	36	34	29	22	10
8BH11T									
8BH15S	8	1,5	2	52	49	45	39	30	15
8BH15T									
8BH22S	13	2,2	3	85	79	73	64	49	25
8BH22T									
8BH30T	17	3	4	111	103	95	83	64	35
8BH40T	23	4	5,5	150	140	129	113	86	43
8BH55T	32	5,5	7,5	208	194	179	157	120	60
8BH75T	43	7,5	10	280	260	241	211	161	81

DIMENSIONS AND WEIGHTS AT 50 Hz

PUMP TYPE	No.OF STAGES	DN	L1 mm	L mm	PUMP WEIGHT kg	ELECTRIC PUMP WEIGHT kg
8BH07S	4	Rp2"	301	662	2,7	12,5
8BH07T				657		11,6
8BH11S	6		363	755	3,2	14,3
8BH11T				755		13,6
8BH15S	8		425	857	3,8	16,8
8BH15T				842		15,3
8BH22S	13		580	1125	5,2	22,9
8BH22T				1050		19,3
8BH30T	17		704	1224	6,3	22,8
8BH40T	23		928	1522	8,4	29,8
8BH55T	32		1207	1911	11	38,7
8BH75T	43		1585	2374	14,5	47,1

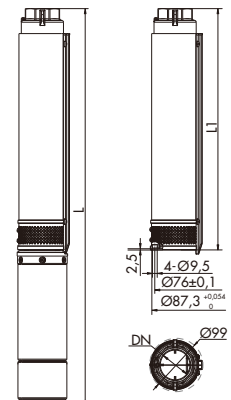

12BH SERIES

OPERATING CHARACTERISTICS AT 50 Hz

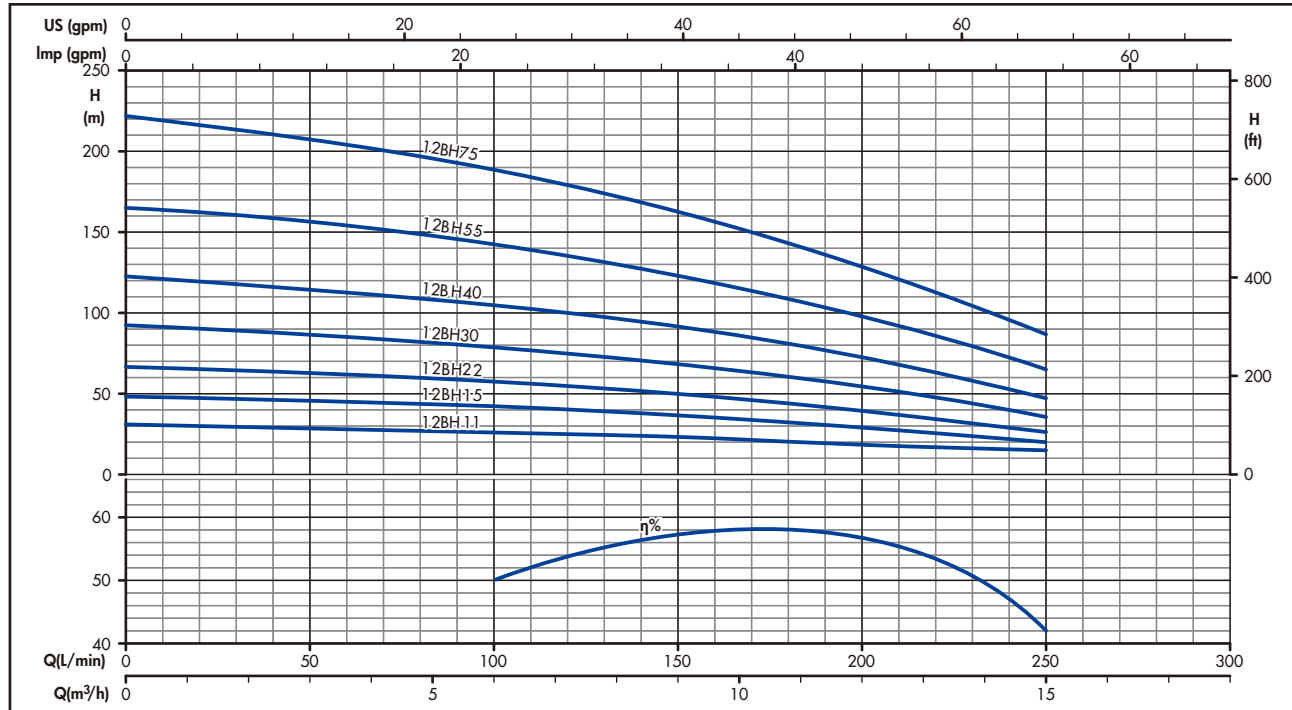

OPERATING CHARACTERISTICS AT 50 Hz

PUMP TYPE	No.OF STAGES	kW	Hp	Q=DELIVERY							
				l/min 0	100	120	140	160	200	250	
				m³/h 0	6	7,2	8,4	9,6	12	15	
H=TOTAL HEAD METERS COLUMN OF WATER											
12BH11S	5	1,1	1,5	31	26	25	24	21	18	12	
12BH11T											
12BH15S	8	1,5	2	49	42	40	38	34	29	19	
12BH15T											
12BH22S	11	2,2	3	67	58	55	52	47	40	26	
12BH22T											
12BH30T	15	3	4	92	79	75	71	65	54	36	
12BH40T	20	4	5,5	122	105	100	94	87	72	48	
12BH55T	27	5,5	7,5	165	142	135	127	117	98	65	
12BH75T	36	7,5	10	221	189	180	169	156	130	87	

DIMENSIONS AND WEIGHTS AT 50 Hz

PUMP TYPE	No.OF STAGES	DN	L1 mm	L mm	PUMP WEIGHT kg	ELECTRIC PUMP WEIGHT kg
12BH11S	5	Rp2"	437	829	3,2	14,3
12BH11T				829		13,6
12BH15S	8		593	1025	4,7	17,7
12BH15T				1010		16,2
12BH22S	11		749	1294	6,1	23,8
12BH22T				1219		20,2
12BH30T	15		994	1514	8,5	25
12BH40T	20		1254	1848	10,8	32,2
12BH55T	27		1655	2359	14,7	42,4
12BH75T	36		2123	2912	19	51,6

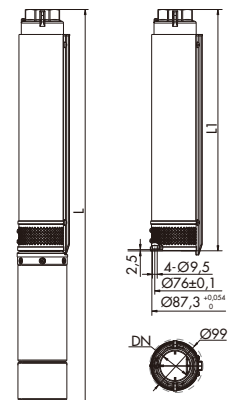

16BH SERIES

OPERATING CHARACTERISTICS AT 50 Hz

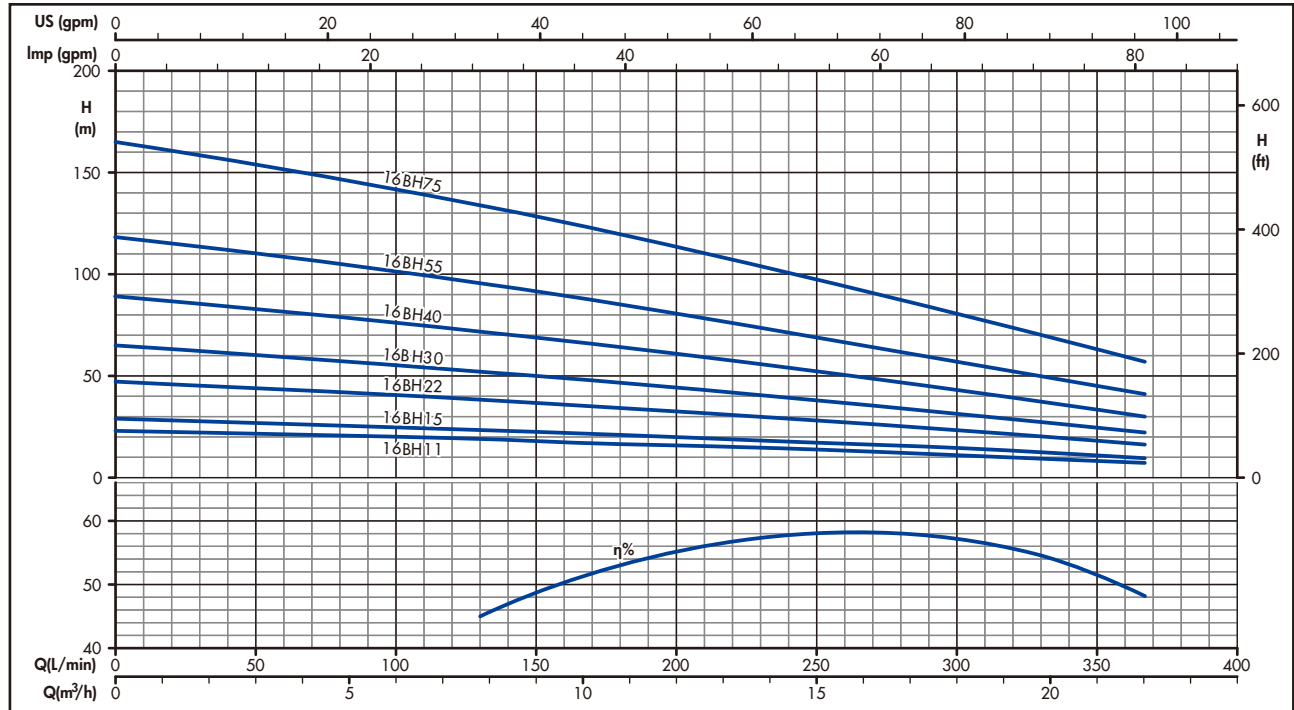

OPERATING CHARACTERISTICS AT 50 Hz

PUMP TYPE	No.OF STAGES	kW	Hp	Q=DELIVERY						
				l/min 0	140	160	200	250	300	367
				m3/h 0	8,4	9,6	12	15	18	22
				H=TOTAL HEAD METERS COLUMN OF WATER						
16BH11S	4	1,1	1,5	23	19	18	16,5	14	11	8
16BH11T										
16BH15S	5	1,5	2	29	23	22	20	17	14	10
16BH15T										
16BH22S	8	2,2	3	47	37	36	32	27	23	16
16BH22T										
16BH30T	11	3	4	65	51	49	44	38	31	22
16BH40T	15	4	5,5	89	70	67	60	51	43	30
16BH55T	20	5,5	7,5	118	97	89	80	69	57	41
16BH75T	28	7,5	10	165	131	125	112	96	80	57

DIMENSIONS AND WEIGHTS AT 50 Hz

PUMP TYPE	No.OF STAGES	DN	L1 mm	L mm	PUMP WEIGHT kg	ELECTRIC PUMP WEIGHT kg
16BH11S	4	Rp2"	449	841	3,5	14,6
16BH11T				841		13,9
16BH15S	5		517	949	4,1	17,1
16BH15T				934		15,6
16BH22S	8		721	1266	6	23,7
16BH22T				1191		20,1
16BH30T	11		962	1482	8,4	24,9
16BH40T	15		1234	1828	10,9	32,3
16BH55T	20		1611	2315	13,7	41,4
16BH75T	28		2155	2944	18,8	51,4

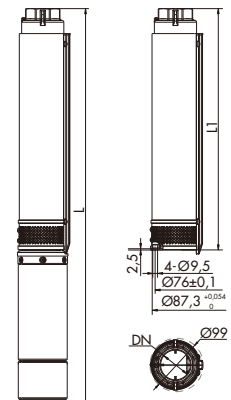

BM SERIES 4" SUBMERSIBLE ELECTRIC PUMPS

*COST-EFFECTIVE VERSION

- Cost-effective submersible electric pumps ensure low cost, high efficiency, better performance and reliability.

APPLICATIONS

- Water supply from deep well.
- Agricultural irrigation.
- Pressure boosting.
- Fire-fighting.
- Industrial application.

SPECIFICATIONS

- Delivery: up to 22 m³/h at 2850 rpm.
- Head: up to 225 m at 2850 rpm.
- Maximum pump overall diameter (cable cover included): 99 mm.
- Maximum permissible quantity of sand: 150 g/m³.
- 1BM , 2BM , 3BM, 4BM , 6BM versions: delivery port Rp1"1/4.
- 8BM , 12BM , 16BM versions: delivery port Rp2" .

MOTOR

- 4OS single-phase version:
from 0,25 to 2,2 kW, 220 V, 50 Hz.
- 4OS three-phase version:
from 0,37 to 2,2 kW, 220 V, 50 Hz.
from 0,37 to 3,0 kW, 380 V, 50 Hz.
- Horizontal operation: 4OS up to 2,2 kW.
- Maximum temperature of water in contact with motor: 35°C .

CONSTRUCTION & CHARACTERISTICS

- Cost-effective construction ensures low cost, high efficiency, better performance and reliability.
- Abrasion resistant construction, floating impellers ensure optimum resistance to abrasion.
- The delivery port and suction support are made of precision-cast stainless steel, guarantee resistance to corrosion, durability and a sturdy coupling to the motor.
- The hexagonal pump shaft guarantees an effective impeller driving.
- A non-return valve is fitted at the discharge to prevent back flow of water and alleviate water hammer to the pump, safeguarding impellers and diffusers.
- The BM series pumps can be coupled with the 4OS motors.
- Vertical and horizontal installation.
- Standard and special versions available.

OPTIONAL FEATURES

- Different voltage and frequency.
- Different materials.



BM SERIES

HYDRAULIC PERFORMANCE RANGE AT 50 Hz

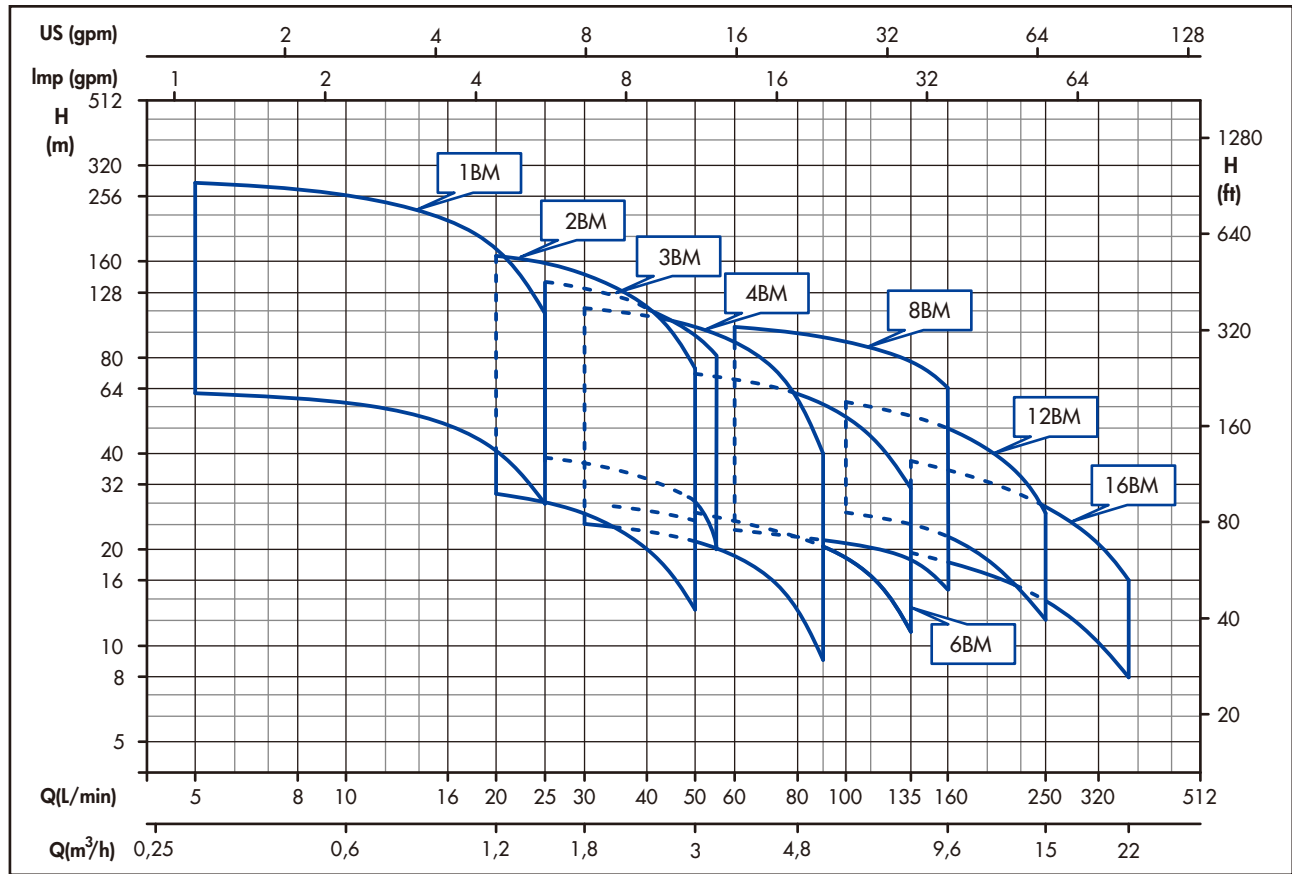

IDENTIFICATION CODE

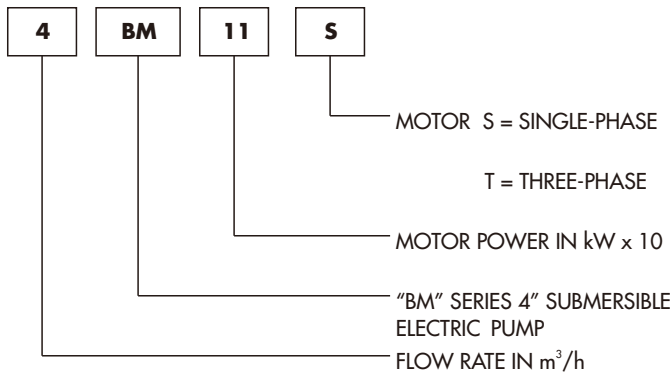

EXAMPLE OF PUMP TYPE

4BM11S

BM series 4" submersible electric pump with flow rate of $4 m^3/h$; and single-phase 1,1 kW (1,5 Hp) motor.



1BM-4BM SERIES

PUMP SECTION AND LIST OF MAIN COMPONENTS MATERIAL

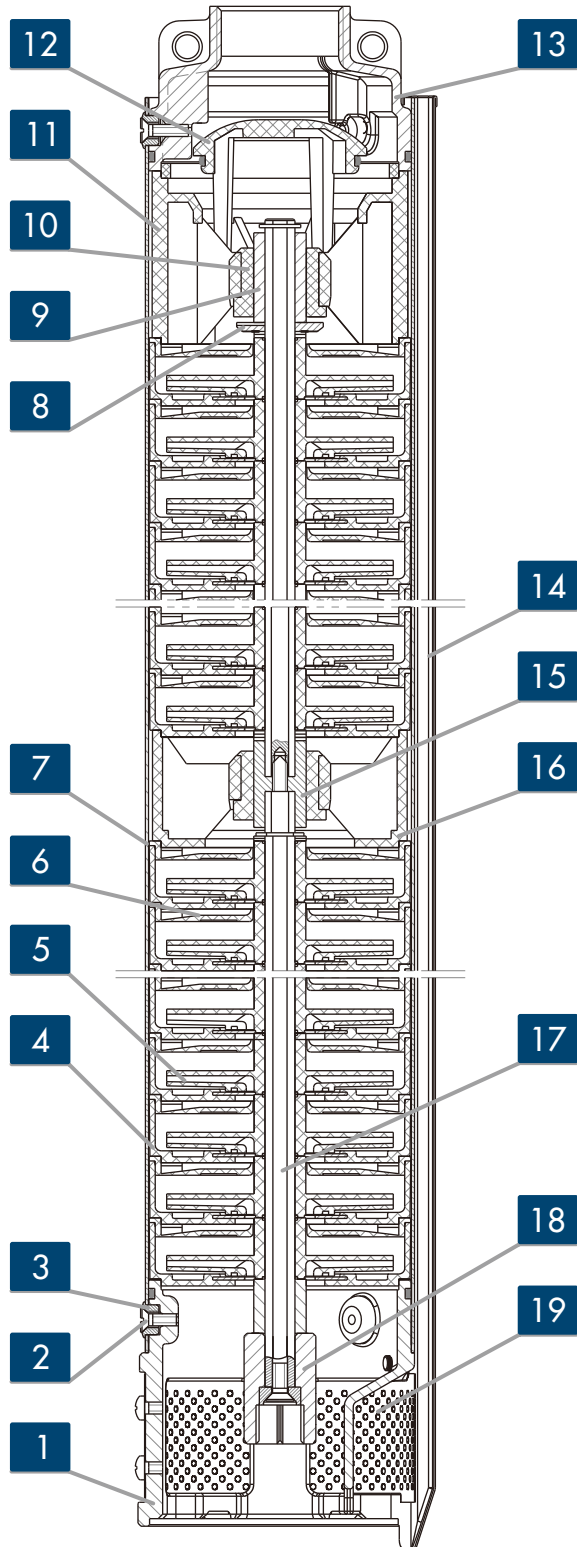

REF.N.	PART	MATERIAL	STANDARD
1	Lower support	Precision-cast stainless steel / cast iron	AISI 304 / ASTM 200A
2	Screw	Stainless steel	AISI 304
3	Pin	Stainless steel	AISI 304
4	Stage housing	ABS	-----
5	Impeller	ABS	-----
6	Diffuser	ABS	-----
7	Outer sleeve	Stainless steel	AISI 304
8	Thrust bearing	Stainless steel	AISI 304
9	Shaft sleeve	Stainless steel	AISI 304
10	Bush bearing	TPU	-----
11	Upper support	ABS	-----
12	Non-return valve	ABS	-----
13	Delivery port	Precision-cast stainless steel / cast iron	AISI 304 / ASTM 200A
14	Cable guard	Stainless steel	AISI 304
15	Intermediate shaft sleeve	Stainless steel	AISI 304
16	Intermediate support	ABS	-----
17	Shaft	Stainless steel	AISI 420
18	Coupling	Stainless steel	AISI 304
19	Filter	Stainless steel	AISI 304

6BM-8BM SERIES

PUMP SECTION AND LIST OF MAIN COMPONENTS MATERIAL

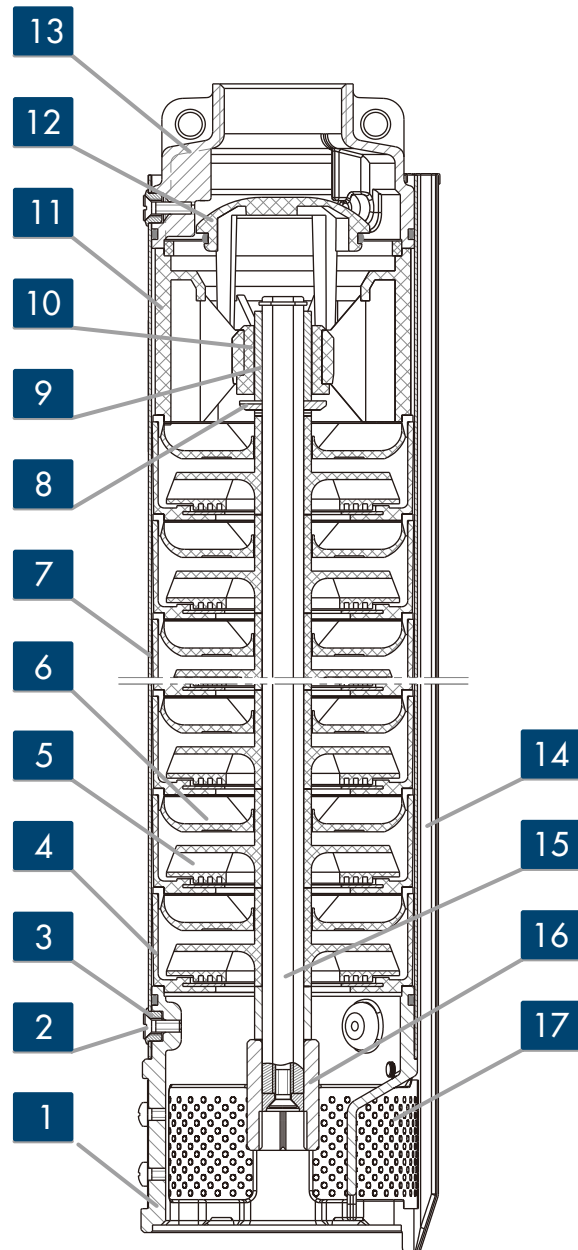

REF.N.	PART	MATERIAL	STANDARD
1	Lower support	Precision-cast stainless steel / cast iron	AISI 304 / ASTM 200A
2	Screw	Stainless steel	AISI 304
3	Pin	Stainless steel	AISI 304
4	Stage housing	ABS	-----
5	Impeller	ABS	-----
6	Diffuser	ABS	-----
7	Outer sleeve	Stainless steel	AISI 304
8	Thrust bearing	Stainless steel	AISI 304
9	Shaft sleeve	Stainless steel	AISI 304
10	Bush bearing	TPU	-----
11	Upper support	ABS	-----
12	Non-return valve	ABS	-----
13	Delivery port	Precision-cast stainless steel / cast iron	AISI 304 / ASTM 200A
14	Cable guard	Stainless steel	AISI 304
15	Shaft	Stainless steel	AISI 420
16	Coupling	Stainless steel	AISI 304
17	Filter	Stainless steel	AISI 304

12BM SERIES

PUMP SECTION AND LIST OF MAIN COMPONENTS MATERIAL

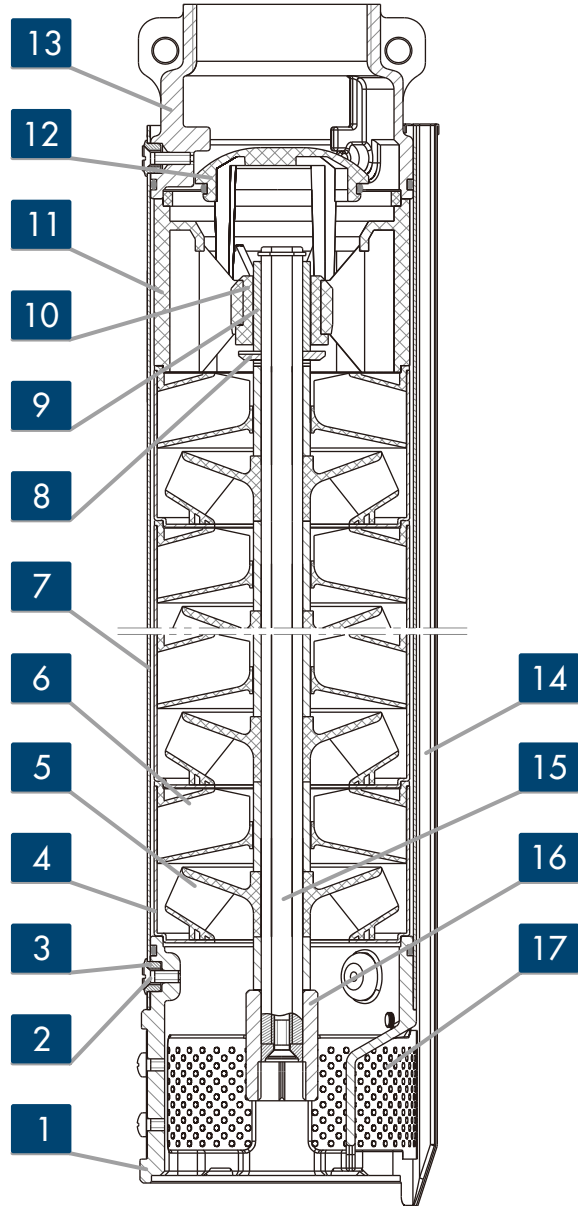

REF.N.	PART	MATERIAL	STANDARD
1	Lower support	Precision-cast stainless steel /cast iron	AISI 304
2	Screw	Stainless steel	AISI 304
3	Pin	Stainless steel	AISI 304
4	Stage housing	Stainless steel	AISI 304
5	Impeller	Noryl® PPO	-----
6	Diffuser	Noryl® PPO	-----
7	Outer sleeve	Stainless steel	AISI 304
8	Thrust bearing	Stainless steel	AISI 304
9	Shaft sleeve	Stainless steel	AISI 304
10	Bush bearing	TPU	-----
11	Upper support	ABS	-----
12	Non-return valve	ABS	-----
13	Delivery port	Precision-cast stainless steel /cast iron	AISI 304
14	Cable guard	Stainless steel	AISI 304
15	Shaft	Stainless steel	AISI 420
16	Coupling	Stainless steel	AISI 304
17	Filter	Stainless steel	AISI 304

16BM SERIES

PUMP SECTION AND LIST OF MAIN COMPONENTS MATERIAL

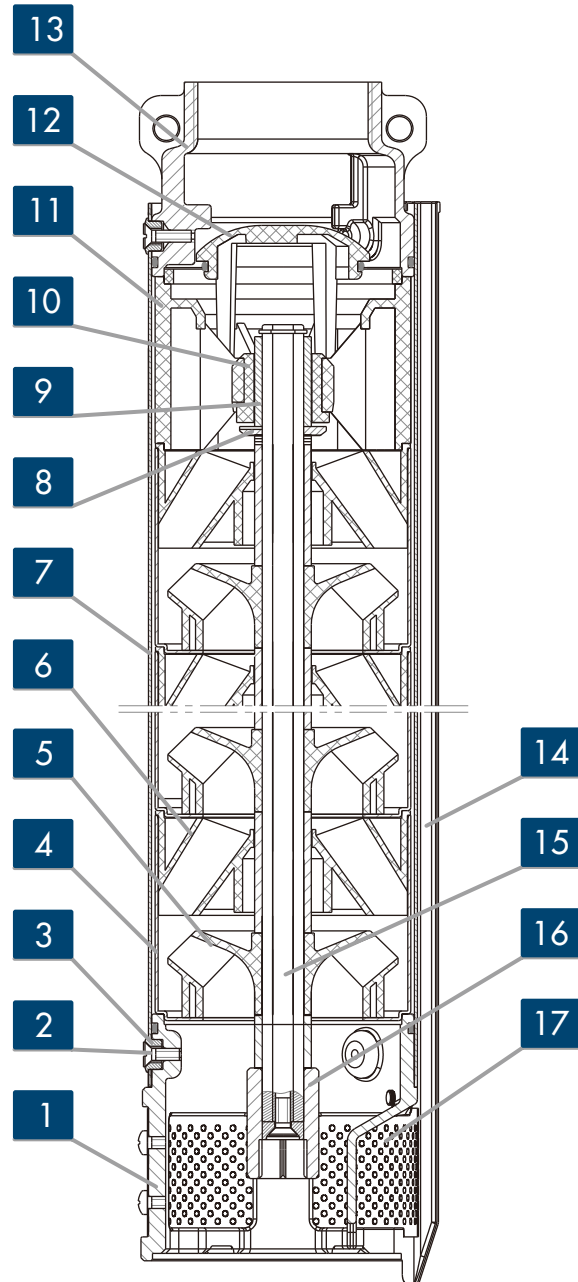

REF.N.	PART	MATERIAL	STANDARD
1	Lower support	Precision-cast stainless steel /cast iron	AISI 304 /ASTM 200A
2	Screw	Stainless steel	AISI 304
3	Pin	Stainless steel	AISI 304
4	Stage housing	Stainless steel	AISI 304
5	Impeller	Noryl® PPO	-----
6	Diffuser	Noryl® PPO	-----
7	Outer sleeve	Stainless steel	AISI 304
8	Thrust bearing	Stainless steel	AISI 304
9	Shaft sleeve	Stainless steel	AISI 304
10	Bush bearing	TPU	-----
11	Upper support	ABS	-----
12	Non-return valve	ABS	-----
13	Delivery port	Precision-cast stainless steel /cast iron	AISI 304 /ASTM 200A
14	Cable guard	Stainless steel	AISI 304
15	Shaft	Stainless steel	AISI 420
16	Coupling	Stainless steel	AISI 304
17	Filter	Stainless steel	AISI 304

1BM SERIES

OPERATING CHARACTERISTICS AT 50 Hz

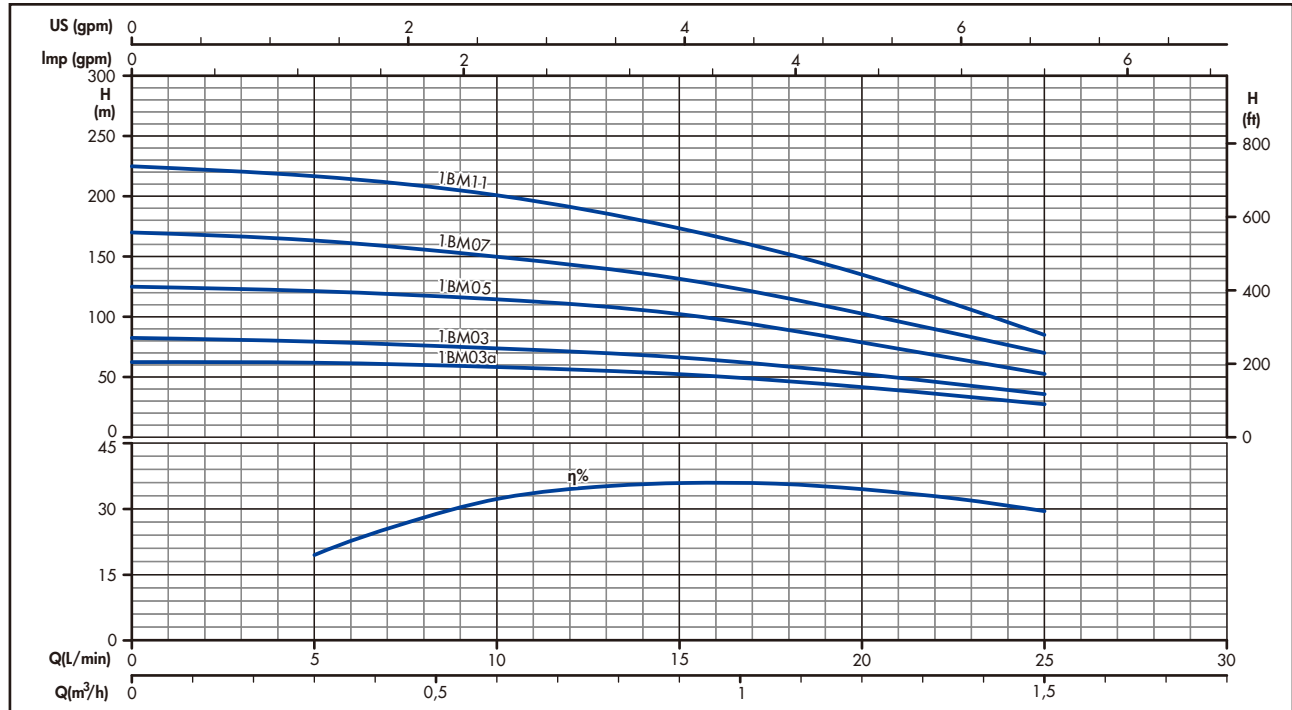

OPERATING CHARACTERISTICS AT 50 Hz

PUMP TYPE	No. OF STAGES	kW	Hp	Q=DELIVERY					
				l/min 0	5	10	15	20	25
				m³/h 0	0,3	0,6	0,9	1,2	1,5
H=TOTAL HEAD METERS COLUMN OF WATER									
1BM03Sa	10	0,37	0,5	64	62	57	52	40	28
1BM03S	13	0,37	0,5	82	80	73	68	52	36
1BM03T									
1BM05S	19	0,55	0,75	125	120	110	102	76	54
1BM05T									
1BM07S	26	0,75	1	169	163	149	131	100	70
1BM07T									
1BM11S	37	1,1	1,5	225	218	200	172	135	85
1BM11T									

DIMENSIONS AND WEIGHTS AT 50 Hz

PUMP TYPE	No. OF STAGES	DN	L1 mm	L mm	PUMP WEIGHT kg	ELECTRIC PUMP WEIGHT kg
1BM03Sa	10	Rp1"1/4	369	695	3,1	11,3
1BM03S	13		423	749	3,5	11,7
1BM03T			423	749		11,3
1BM05S	19		528	869	4,5	13,4
1BM05T			528	864		12,5
1BM07S	26		652	1013	5,4	15,2
1BM07T			652	1008		14,3
1BM11S	37		882	1274	7,1	18,2
1BM11T			882	1274		17,5

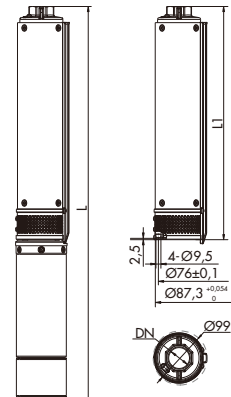

2BM SERIES

OPERATING CHARACTERISTICS AT 50 Hz

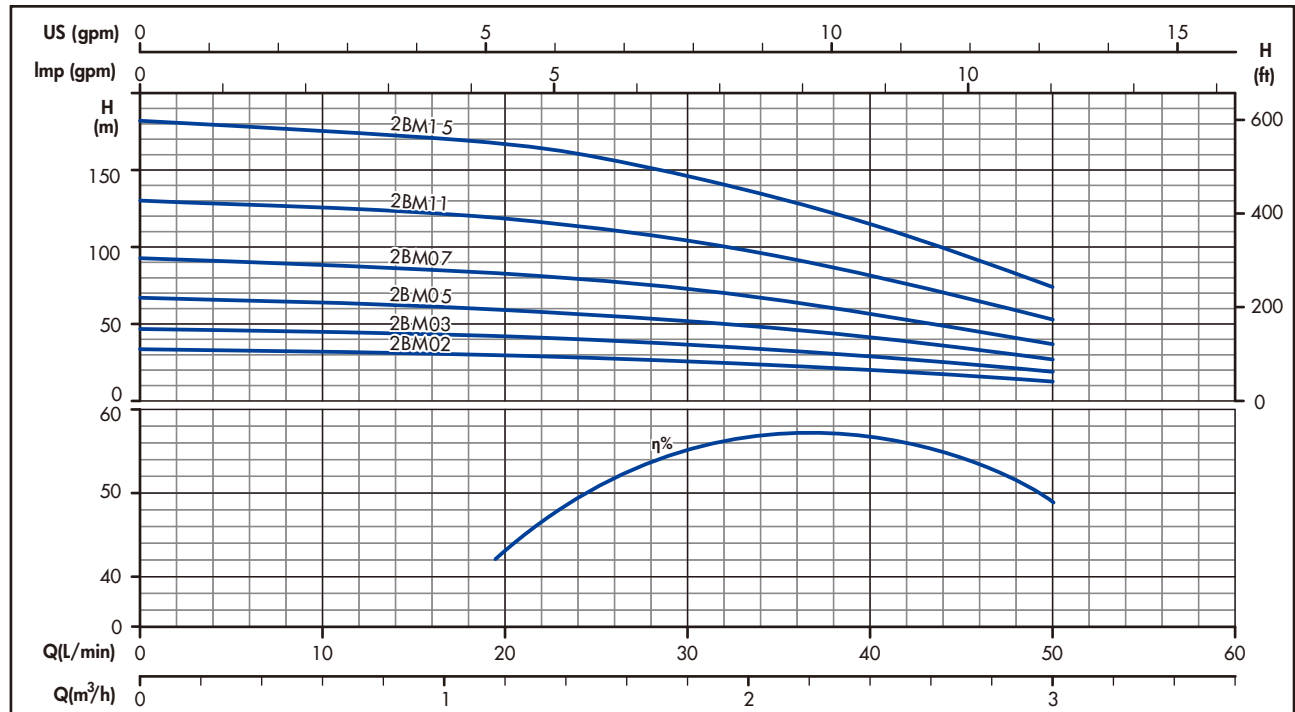

OPERATING CHARACTERISTICS AT 50 Hz

PUMP TYPE	No.OF STAGES	kW	Hp	Q=DELIVERY					
				l/min 0	20	25	30	40	50
				m³/h 0	1,2	1,5	1,8	2,4	3
H=TOTAL HEAD METERS COLUMN OF WATER									
2BM02S	5	0,25	0,33	33	30	28	26	20	13
2BM03S	7	0,37	0,5	47	42	40	36	29	19
2BM03T									
2BM05S	10	0,55	0,75	67	60	56	52	41	27
2BM05T									
2BM07S	14	0,75	1	93	83	79	73	57	37
2BM07T									
2BM11S	20	1,1	1,5	130	119	113	104	82	53
2BM11T									
2BM15S	28	1,5	2	182	167	158	146	115	74
2BM15T									

DIMENSIONS AND WEIGHTS AT 50 Hz

PUMP TYPE	No.OF STAGES	DN	L1 mm	L mm	PUMP WEIGHT kg	ELECTRIC PUMP WEIGHT kg
2BM02S	5	Rp1"1/4	299	615	2,6	10,4
2BM03S	7		341	667	2,8	11
2BM03T				667		10,6
2BM05S	10		405	746	3,3	12,2
2BM05T				741		11,3
2BM07S	14		489	850	3,8	13,6
2BM07T				845		12,7
2BM11S	20		616	1008	4,7	15,8
2BM11T				1008		15,1
2BM15S	28		785	1217	5,7	18,7
2BM15T				1202		17,2

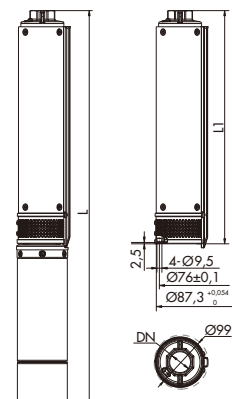

3BM SERIES

OPERATING CHARACTERISTICS AT 50 Hz

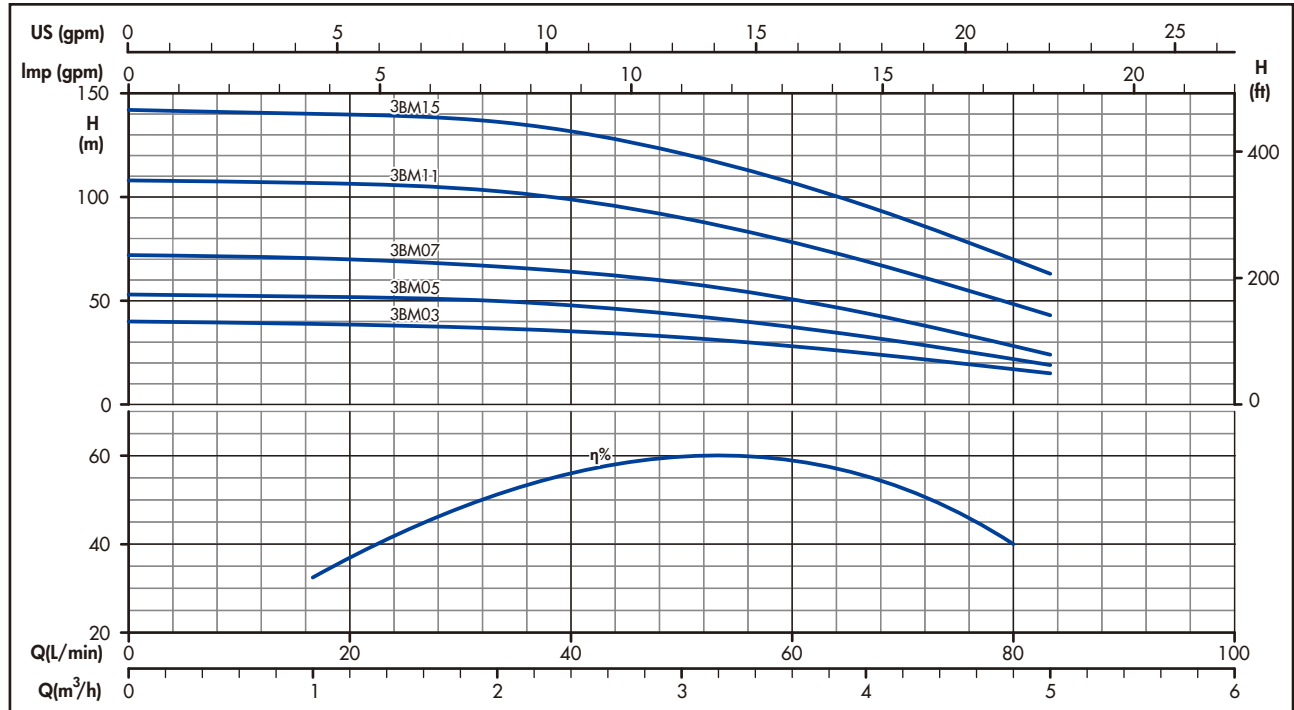

OPERATING CHARACTERISTICS AT 50 Hz

PUMP TYPE	No.OF STAGES	kW	Hp	Q=DELIVERY					
				l/min 0	17	33	50	67	84
				m³/h 0	1	2	3	4	5
H=TOTAL HEAD METERS COLUMN OF WATER									
3BM03S	6	0,37	0,5	40	39	37	33	25	15
3BM03T									
3BM05S	8	0,55	0,75	53	52	50	43	33	19
3BM05T									
3BM07S	11	0,75	1	72	71	67	59	44	24
3BM07T									
3BM11S	16	1,1	1,5	108	107	103	90	69	43
3BM11T									
3BM15S	21	1,5	2	142	141	136	121	96	63
3BM15T									

DIMENSIONS AND WEIGHTS AT 50 Hz

PUMP TYPE	No.OF STAGES	DN	L1 mm	L mm	PUMP WEIGHT kg	ELECTRIC PUMP WEIGHT kg
3BM03S	6	Rp1"1/4	347	673	4,2	12,4
3BM03T				673		12
3BM05S	8		398	739	4,6	13,5
3BM05T				734		12,6
3BM07S	11		474	835	5	14,8
3BM07T				830		13,9
3BM11S	16		602	994	5,7	16,8
3BM11T				994		16,1
3BM15S	21		729	1161	6,5	19,5
3BM15T				1146		18

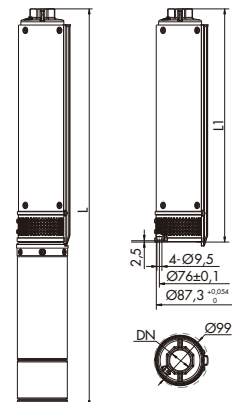

4BM SERIES

OPERATING CHARACTERISTICS AT 50 Hz

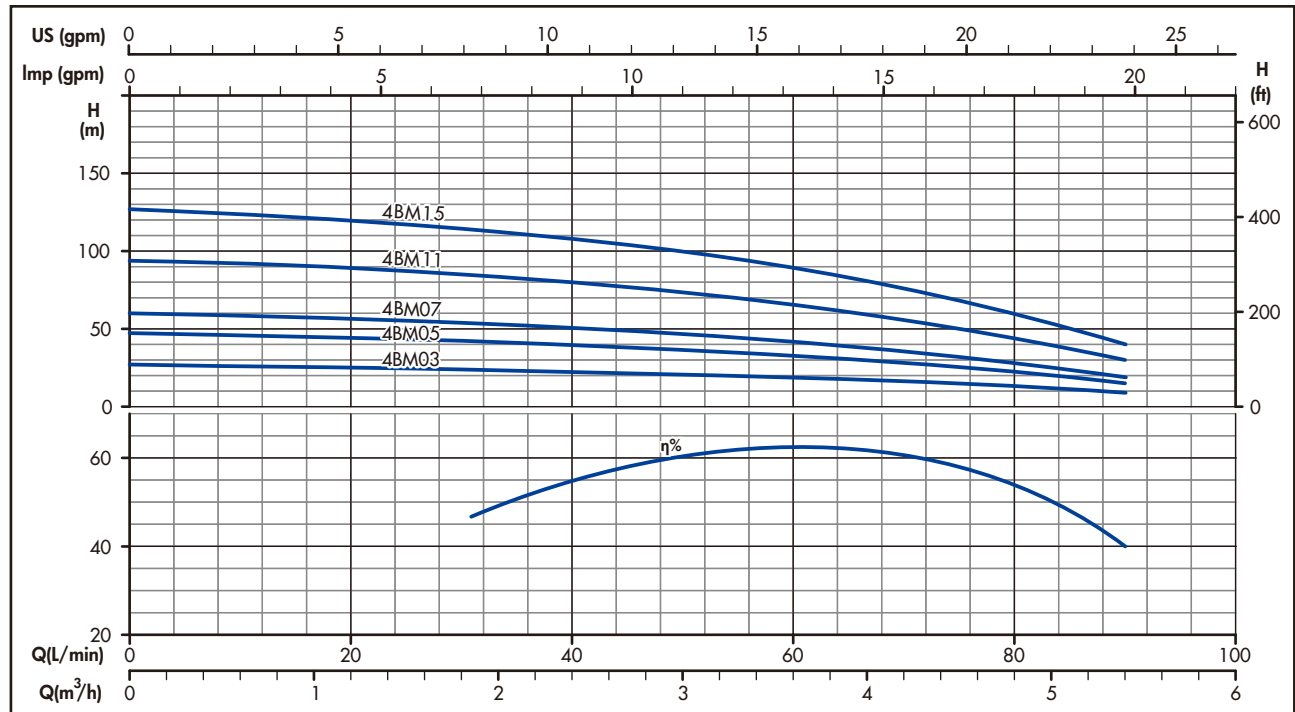

OPERATING CHARACTERISTICS AT 50 Hz

PUMP TYPE	No.OF STAGES	kW	Hp	Q=DELIVERY						
				l/min 0	30	40	50	60	80	90
				m³/h 0	1,8	2,4	3	3,6	4,8	5,4
H=TOTAL HEAD METERS COLUMN OF WATER										
4BM03S	4	0,37	0,5	27	24	23	21	19	13	9
4BM03T										
4BM05S	7	0,55	0,75	47	42	40	37	33	22	15
4BM05T										
4BM07S	9	0,75	1	60	54	51	47	42	28	19
4BM07T										
4BM11S	14	1,1	1,5	94	84	80	74	66	44	30
4BM11T										
4BM15S	19	1,5	2	127	114	108	100	89	60	40
4BM15T										

DIMENSIONS AND WEIGHTS AT 50 Hz

PUMP TYPE	No.OF STAGES	DN	L1 mm	L mm	PUMP WEIGHT kg	ELECTRIC PUMP WEIGHT kg
4BM03S	4	Rp1"1/4	296	622	2,5	10,7
4BM03T				622		10,3
4BM05S	7		371	712	3	11,9
4BM05T				707		11
4BM07S	9		423	784	3,4	13,2
4BM07T				779		12,3
4BM11S	14		550	942	4,3	15,4
4BM11T				942		14,7
4BM15S	19		677	1109	5,6	18,6
4BM15T				1094		17,1

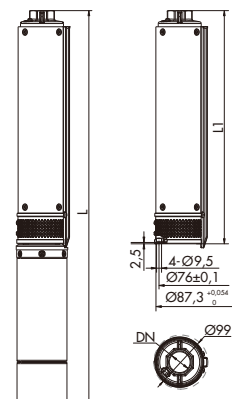

6BM SERIES

OPERATING CHARACTERISTICS AT 50 Hz

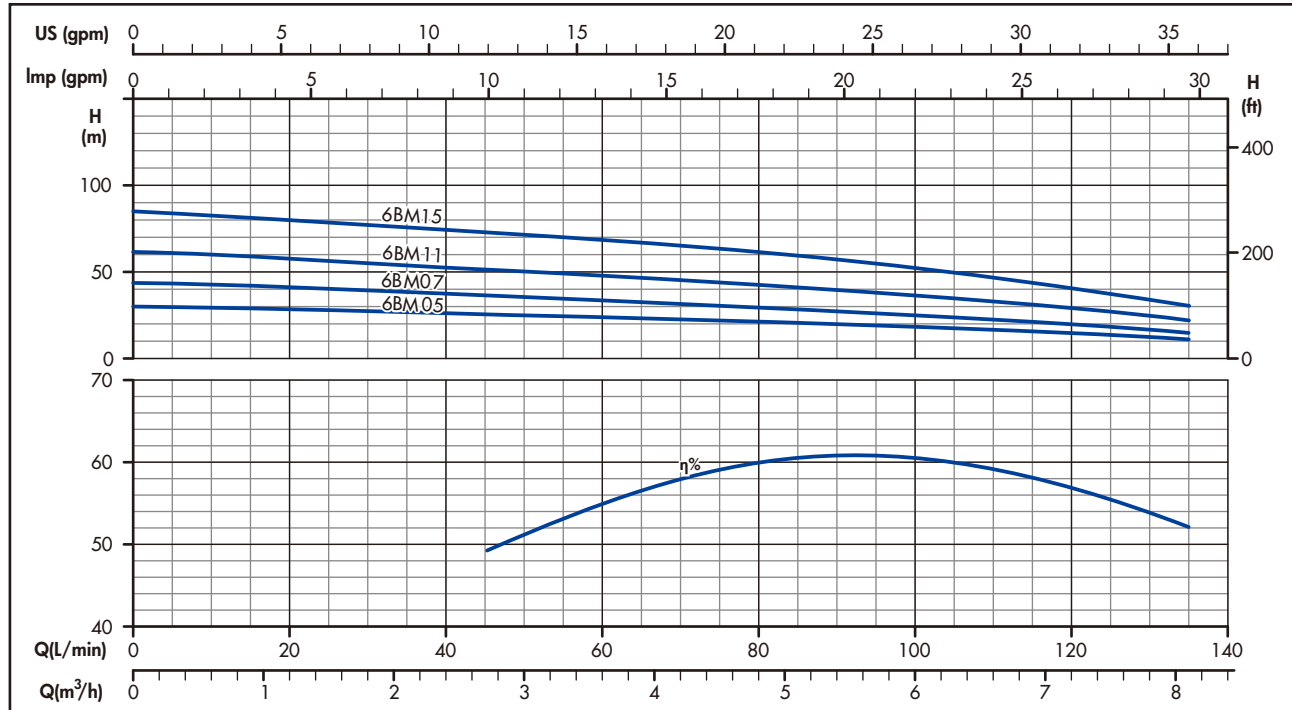

OPERATING CHARACTERISTICS AT 50 Hz

PUMP TYPE	No. OF STAGES	kW	Hp	Q=DELIVERY						
				l/min 0	60	75	90	105	120	135
				H=TOTAL HEAD METERS COLUMN OF WATER						
				m³/h 0	3,6	4,5	5,4	6,3	7,2	8,1
6BM05S	5	0,55	0,75	30	25	23	20	18	15	11
6BM05T										
6BM07S	7	0,75	1	43	35	32	28	24	20	15
6BM07T										
6BM11S	10	1,1	1,5	61	49	46	41	35	30	22
6BM11T										
6BM15S	14	1,5	2	85	69	64	57	50	41	31
6BM15T										

DIMENSIONS AND WEIGHTS AT 50 Hz

PUMP TYPE	No. OF STAGES	DN	L1 mm	L mm	PUMP WEIGHT kg	ELECTRIC PUMP WEIGHT kg
6BM05S	5	Rp1"1/4	357	698	3	11,9
6BM05T				693		11
6BM07S	7		423	784	3,4	13,2
6BM07T				779		12,3
6BM11S	10		522	914	4,1	15,2
6BM11T				914		14,5
6BM15S	14		655	1087	4,9	17,9
6BM15T				1072		16,4

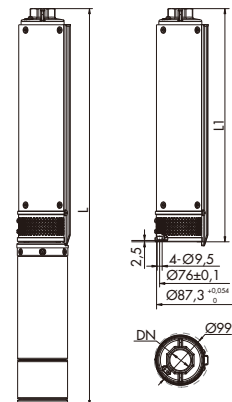

8BM SERIES

OPERATING CHARACTERISTICS AT 50 Hz

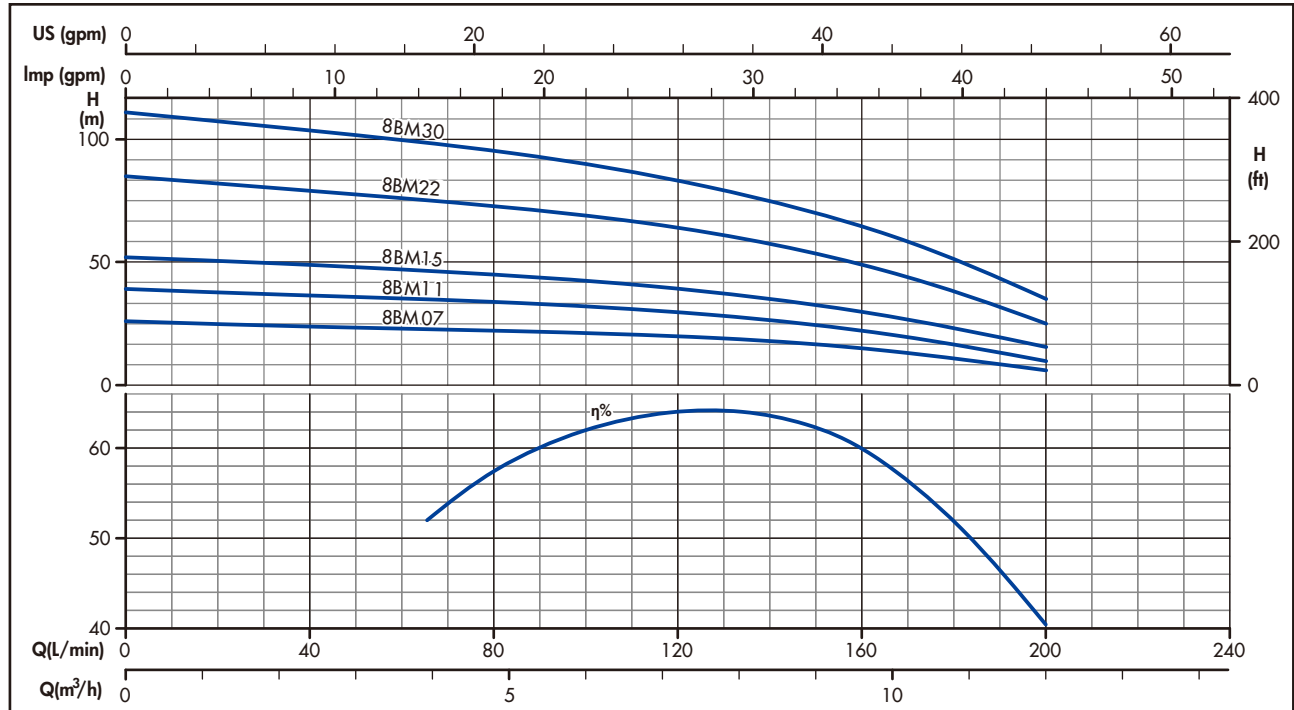

OPERATING CHARACTERISTICS AT 50 Hz

PUMP TYPE	No. OF STAGES	kW	Hp	Q=DELIVERY					
				l/min 0	40	80	120	160	200
				m ³ /h 0	2,4	4,8	7,2	9,6	12
H=TOTAL HEAD METERS COLUMN OF WATER									
8BM07S	4	0,75	1	26	24	22	20	15	6
8BM07T									
8BM11S	6	1,1	1,5	39	36	34	29	22	10
8BM11T									
8BM15S	8	1,5	2	52	49	45	39	30	15
8BM15T									
8BM22S	13	2,2	3	85	79	73	64	49	25
8BM22T									
8BM30T	17	3	4	111	103	95	83	64	35

DIMENSIONS AND WEIGHTS AT 50 Hz

PUMP TYPE	No. OF STAGES	DN	L1 mm	L mm	PUMP WEIGHT kg	ELECTRIC PUMP WEIGHT kg
8BM07S	4	Rp2"	334	695	2,7	12,5
8BM07T				690		11,6
8BM11S	6		400	792	3,2	14,3
8BM11T				792		13,6
8BM15S	8		466	898	3,6	16,6
8BM15T				883		15,1
8BM22S	13		631	1176	4,7	22,4
8BM22T				1101		18,8
8BM30T	17		764	1284	5,6	22

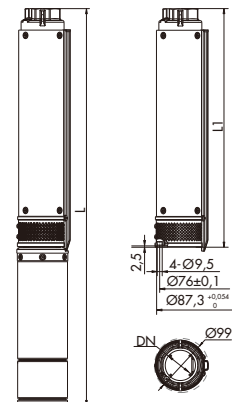

12BM SERIES

OPERATING CHARACTERISTICS AT 50 Hz

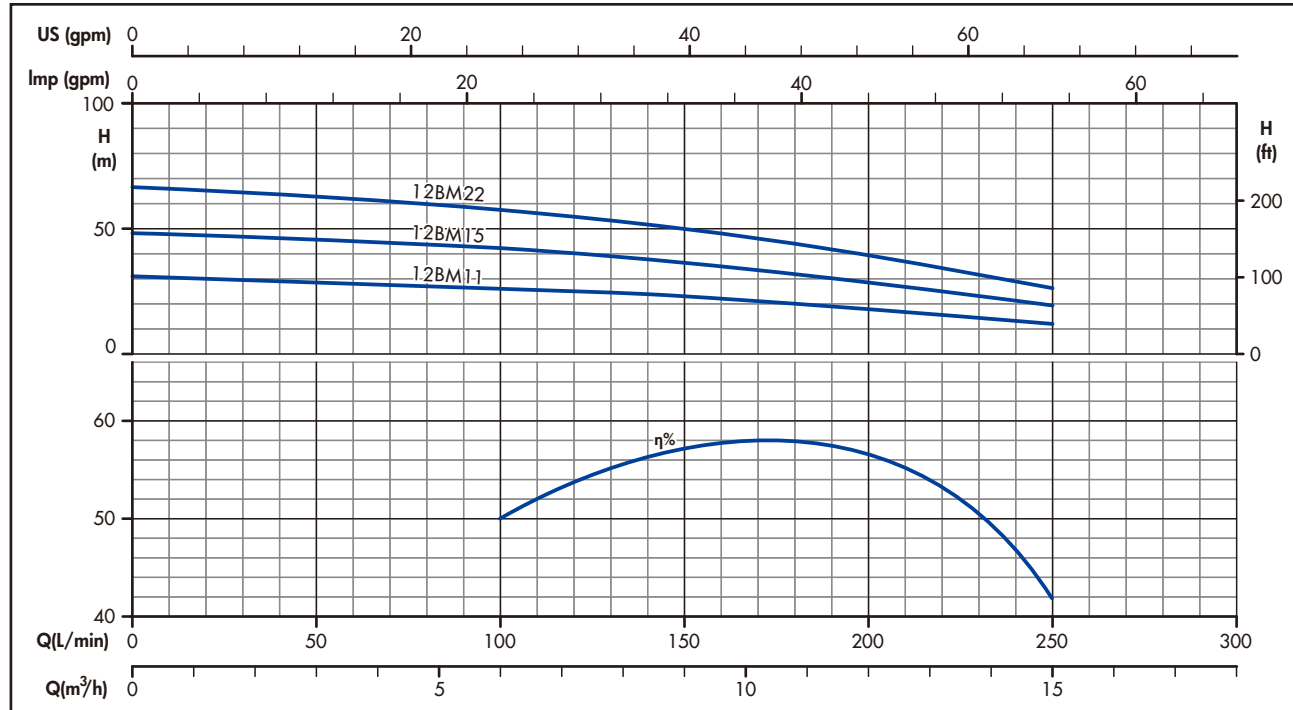

OPERATING CHARACTERISTICS AT 50 Hz

PUMP TYPE	No.OF STAGES	kW	Hp	Q=DELIVERY						
				l/min 0	100	120	140	160	200	250
				m³/h 0	6	7,2	8,4	9,6	12	15
H=TOTAL HEAD METERS COLUMN OF WATER										
12BM11S	5	1,1	1,5	31	26	25	24	21	18	12
12BM11T										
12BM15S	8	1,5	2	49	42	40	38	34	29	19
12BM15T										
12BM22S	11	2,2	3	67	58	55	52	47	40	26
12BM22T										

DIMENSIONS AND WEIGHTS AT 50 Hz

PUMP TYPE	No.OF STAGES	DN	L1 mm	L mm	PUMP WEIGHT kg	ELECTRIC PUMP WEIGHT kg
12BM11S	5	Rp2"	464	856	3,9	15
12BM11T				856		14,3
12BM15S	8		620	1052	5,2	18,2
12BM15T				1037		16,7
12BM22S	11		776	1321	6,4	24,1
12BM22T				1246		20,5

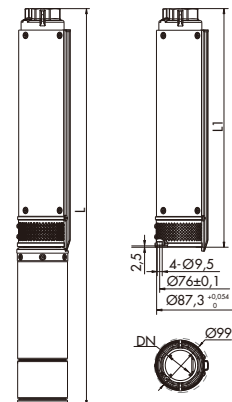

16BM SERIES

OPERATING CHARACTERISTICS AT 50 Hz

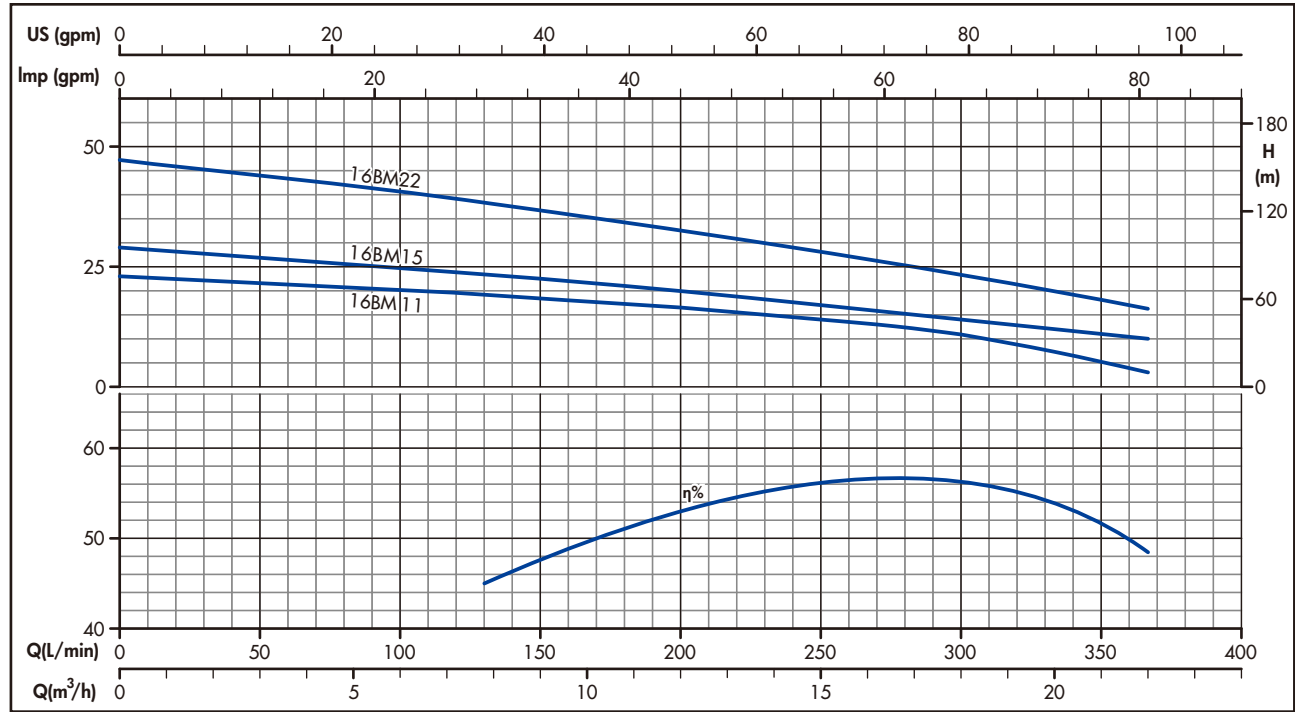

OPERATING CHARACTERISTICS AT 50 Hz

PUMP TYPE	No.OF STAGES	kW	Hp	Q=DELIVERY						
				l/min 0	140	160	200	250	300	367
				m³/h 0	8,4	9,6	12	15	18	22
				H=TOTAL HEAD METERS COLUMN OF WATER						
16BM11S	4	1,1	1,5	23	19	18	16,5	14	11	8
16BM11T										
16BM15S	5	1,5	2	29	23	22	20	17	14	10
16BM15T										
16BM22S	8	2,2	3	47	37	36	32	27	23	16
16BM22T										

DIMENSIONS AND WEIGHTS AT 50 Hz

PUMP TYPE	No.OF STAGES	DN	L1 mm	L mm	PUMP WEIGHT kg	ELECTRIC PUMP WEIGHT kg
16BM11S	4	Rp2"	475	867	3,9	15
16BM11T				867		14,3
16BM15S	5		543	975	4,4	17,4
16BM15T				960		15,9
16BM22S	8		747	1292	6	23,7
16BM22T				1217		20,1

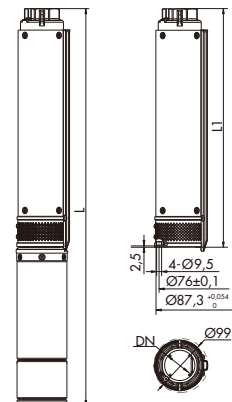

SP SERIES 4" SUBMERSIBLE ELECTRIC PUMPS



- Completely made of corrosion-resistant stainless steel AISI 304, SP pumps are ideal for a wide variety of applications with high efficiency and reliability.

APPLICATIONS

- Water supply from deep well.
- Agricultural irrigation.
- Pressure boosting.
- Fire-fighting.
- Industrial application.

SPECIFICATIONS

- Delivery: up to 19 m³/h at 2850 rpm.
- Head: up to 378 m at 2850 rpm.
- Maximum overall diameter of pump: 99 mm (cable guard included).
- Maximum permissible quantity of suspended sand: 150 g/m³.
- 2SP , 3SP versions: delivery port Rp1"1/4.
- 5SP , 6SP versions: delivery port Rp1"1/2.
- 8SP , 14SP versions: delivery port Rp2".

MOTOR

- 4OS single-phase version:
from 0,37 to 2,2 kW, 220 V, 50 Hz.
- 4OS three-phase version:
from 0,37 to 7,5 kW, 380 V, 50 Hz.

CONSTRUCTION & CHARACTERISTICS

- Sturdy and lightweight, easy to maintain and resistant to corrosion in non-aggressive environments.
- High efficient hydraulic design for cost saving and best performance.
- Stainless steel built-in non-return valve.
- Stainless steel impellers and diffusers.
- Stainless steel delivery port and suction support.
- Stainless steel shaft and replaceable coupling.
- Stainless steel floating wear ring & NBR bush bearings ensure maximum resistance to wear and long-lasting performance and reliability.
- Coupling and flange mounting dimensions meet NEMA standards.
- The SP series pumps can be coupled with the 4OS motors.

OPTIONAL FEATURES

- Different voltage and frequency.

SP SERIES

HYDRAULIC PERFORMANCE RANGE AT 50 Hz

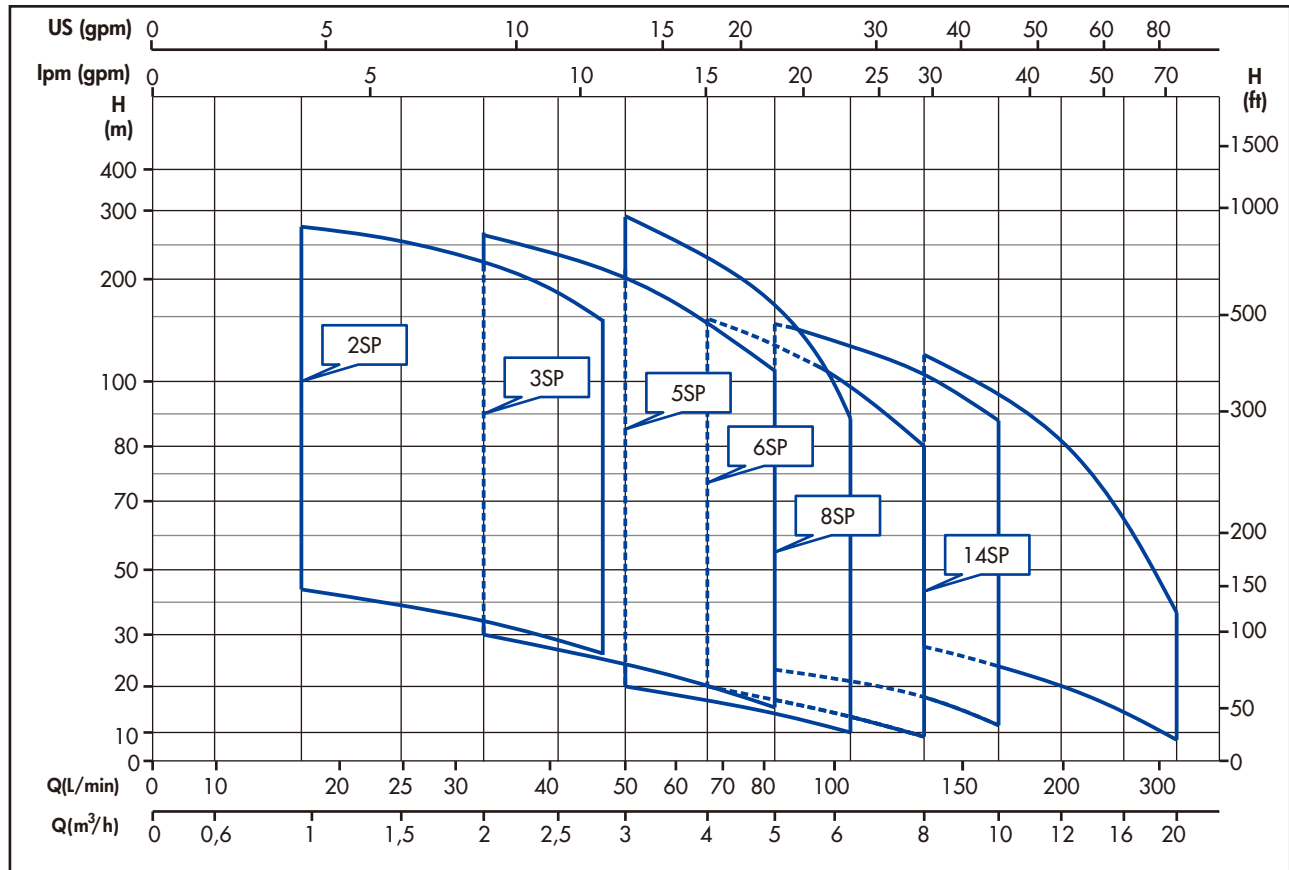

IDENTIFICATION CODE

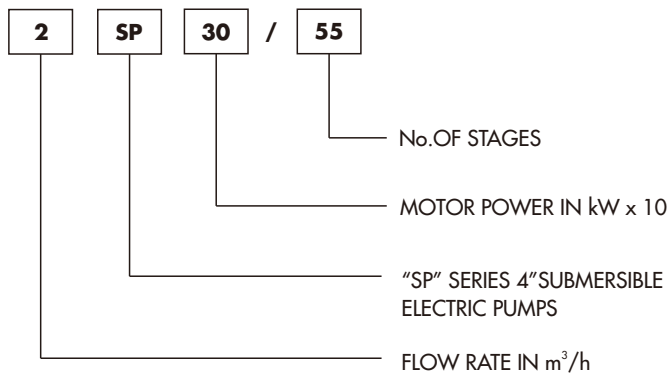

EXAMPLE OF PUMP TYPE

2SP30/55

SP series 4" submersible electric pump with flow rate $2 m^3/h$, 55 stages, and 4" submersible motor 3,0kW(4Hp).



1SP-5SP SERIES

PUMP SECTION AND LIST OF MAIN COMPONENTS MATERIAL

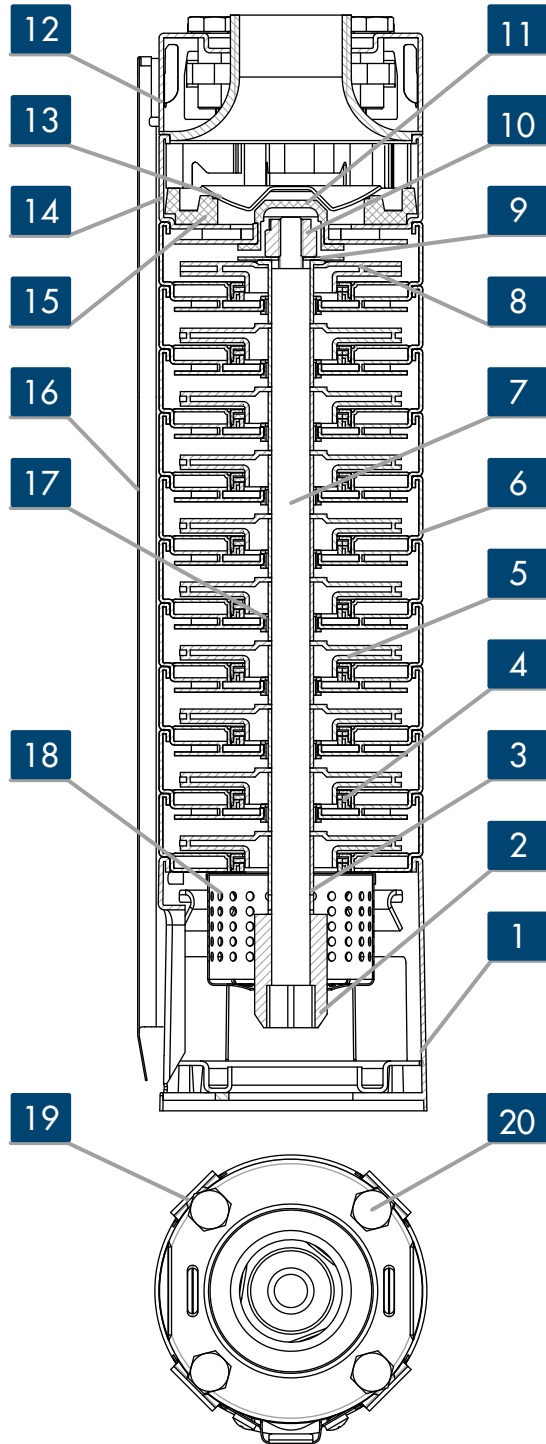

REF.N.	PART	MATERIAL	STANDARD
1	Lower support	Stainless steel	AISI 304
2	Coupling	Stainless steel	AISI 304
3	Shaft sleeve	Stainless steel	AISI 304
4	Neck ring	NBR	-----
5	Impeller	Stainless steel	AISI 304
6	Diffuser	Stainless steel	AISI 304
7	Shaft	Stainless steel	AISI 304
8	End-stage impeller	Stainless steel	AISI 304
9	Thrust washer	Stainless steel	AISI 304
10	Nut	Stainless steel	AISI 304
11	Thrust bearing	NBR	AISI 304
12	Delivery port	Stainless steel	AISI 304
13	Non-return valve	Stainless steel	AISI 304
14	End-stage diffuser	Stainless steel	AISI 304
15	Valve support	NBR	-----
16	Cable guard	Stainless steel	AISI 304
17	Bush bearing	NBR	-----
18	Suction inlet	Stainless steel	AISI 304
19	Strap	Stainless steel	AISI 304
20	Bolt	Stainless steel	AISI 304

8SP SERIES

PUMP SECTION AND LIST OF MAIN COMPONENTS MATERIAL

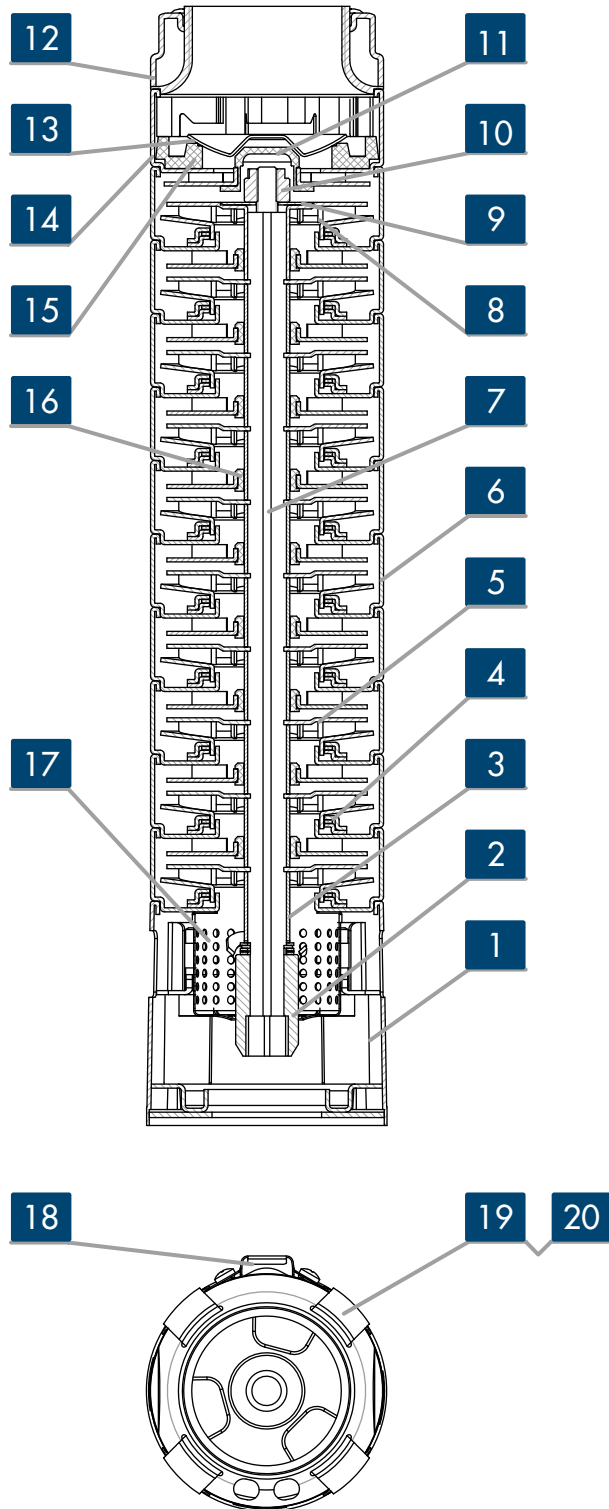

REF.N.	PART	MATERIAL	STANDARD
1	Lower support	Stainless steel	AISI 304
2	Coupling	Stainless steel	AISI 304
3	Shaft sleeve	Stainless steel	AISI 304
4	Neck ring	NBR	-----
5	Impeller	Stainless steel	AISI 304
6	Diffuser	Stainless steel	AISI 304
7	Shaft	Stainless steel	AISI 304
8	End-stage impeller	Stainless steel	AISI 304
9	Thrust washer	Stainless steel	AISI 304
10	Nut	Stainless steel	AISI 304
11	Thrust bearing	NBR	-----
12	Delivery port	Stainless steel	AISI 304
13	Non-return valve	Stainless steel	AISI 304
14	End-stage diffuser	Stainless steel	AISI 304
15	Valve support	NBR	-----
16	Bush bearing	NBR	-----
17	Suction inlet	Stainless steel	AISI 304
18	Cable guard	Stainless steel	AISI 304
19	Strap	Stainless steel	AISI 304
20	Bolt	Stainless steel	AISI 304

14SP SERIES

PUMP SECTION AND LIST OF MAIN COMPONENTS MATERIAL

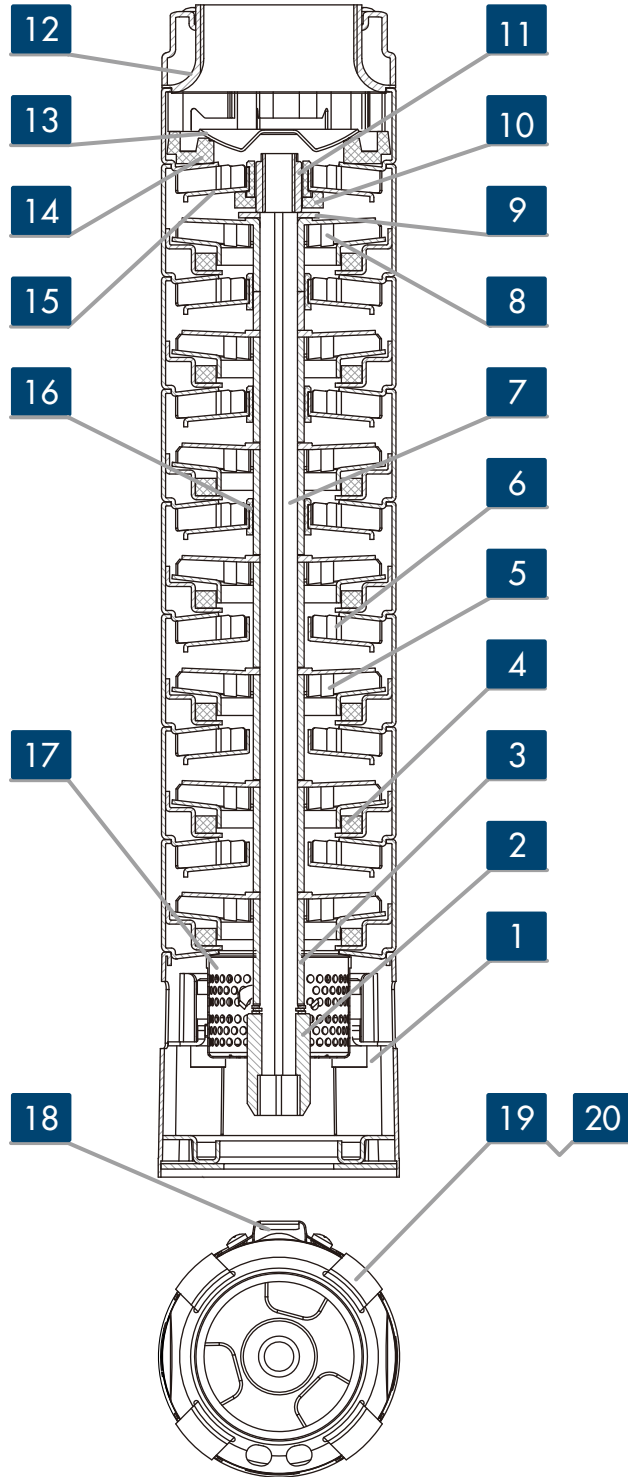

REF.N.	PART	MATERIAL	STANDARD
1	Lower support	Stainless steel	AISI 304
2	Coupling	Stainless steel	AISI 304
3	Shaft sleeve	Stainless steel	AISI 304
4	Neck ring	Stainless steel	AISI 304
5	Impeller	Stainless steel	AISI 304
6	Diffuser	Stainless steel	AISI 304
7	Shaft	Stainless steel	AISI 304
8	End-stage impeller	Stainless steel	AISI 304
9	Thrust washer	Stainless steel	AISI 304
10	Thrust bearing	PTFE	-----
11	Nut	Stainless steel	AISI 304
12	Delivery port	Stainless steel	AISI 304
13	Valve support	NBR	-----
14	Non-return valve	Stainless steel	AISI 304
15	End-stage diffuser	Stainless steel	AISI 304
16	Bush bearing	NBR	-----
17	Suction inlet	Stainless steel	AISI 304
18	Cable guard	Stainless steel	AISI 304
19	Strap	Stainless steel	AISI 304
20	Bolt	Stainless steel	AISI 304

2SP SERIES

OPERATING CHARACTERISTICS AT 50 Hz

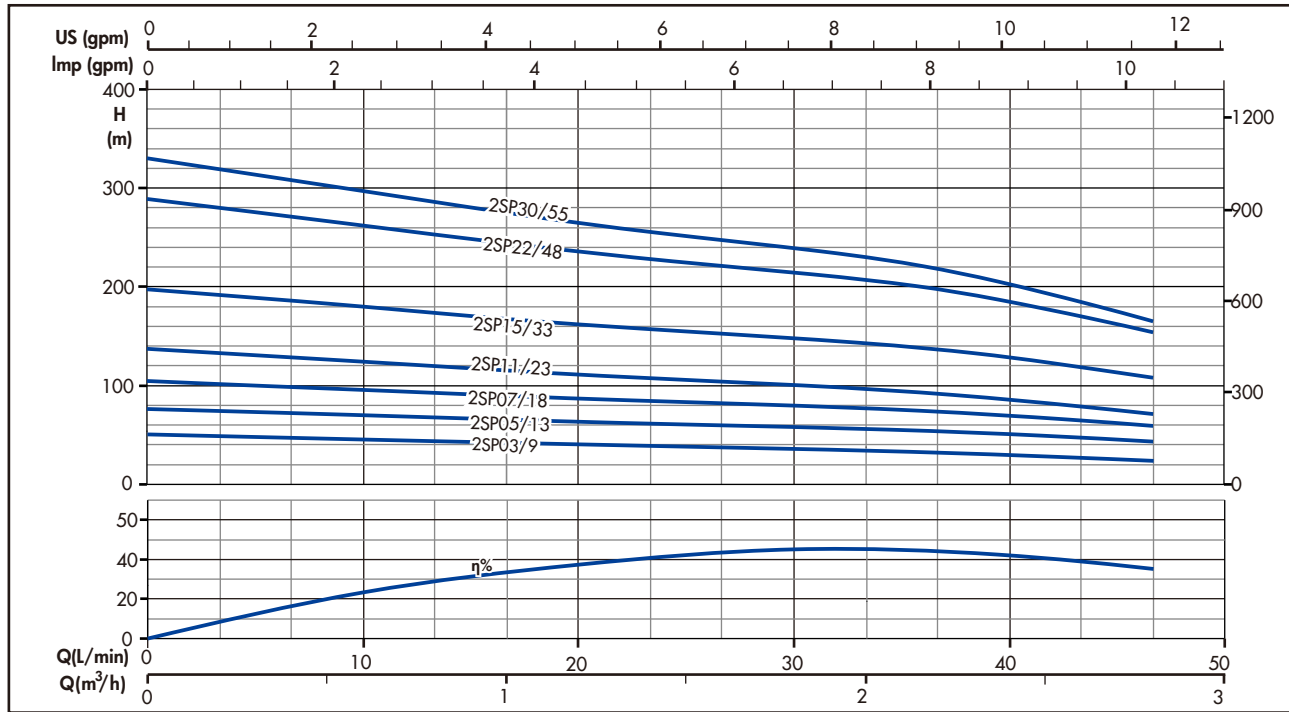

OPERATING CHARACTERISTICS AT 50 Hz

PUMP TYPE	No.OF STAGES	kW	Hp	Q=DELIVERY							
				L/min 0	17	20	27	33	40	47	
				m³/h 0	1	1,2	1,6	2	2,4	2,8	
H=TOTAL HEAD METERS COLUMN OF WATER											
2SP03/9	9	0,37	0,5	54	45	43	41	38	33	27	
2SP05/13	13	0,55	0,75	78	65	62	59	55	48	39	
2SP07/18	18	0,75	1	108	90	86	81	76	67	54	
2SP11/23	23	1,1	1,5	138	115	110	104	97	85	69	
2SP15/33	33	1,5	2	198	165	158	149	139	122	99	
2SP22/48	48	2,2	3	288	240	230	216	202	178	144	
2SP30/55	55	3	4	330	275	264	248	231	204	165	

DIMENSIONS AND WEIGHTS AT 50 Hz

PUMP TYPE	No.OF STAGES	DN	L1 mm	PUMP WEIGHT kg
2SP03/9	9	Rp1"1/4	336	3,4
2SP05/13	13		420	4,3
2SP07/18	18		525	5,4
2SP11/23	23		630	6,5
2SP15/33	33		840	8,7
2SP22/48	48		1155	12
2SP30/55	55		1303	13,8

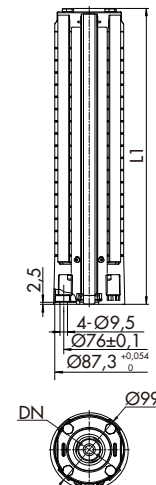

3SP SERIES

OPERATING CHARACTERISTICS AT 50 Hz

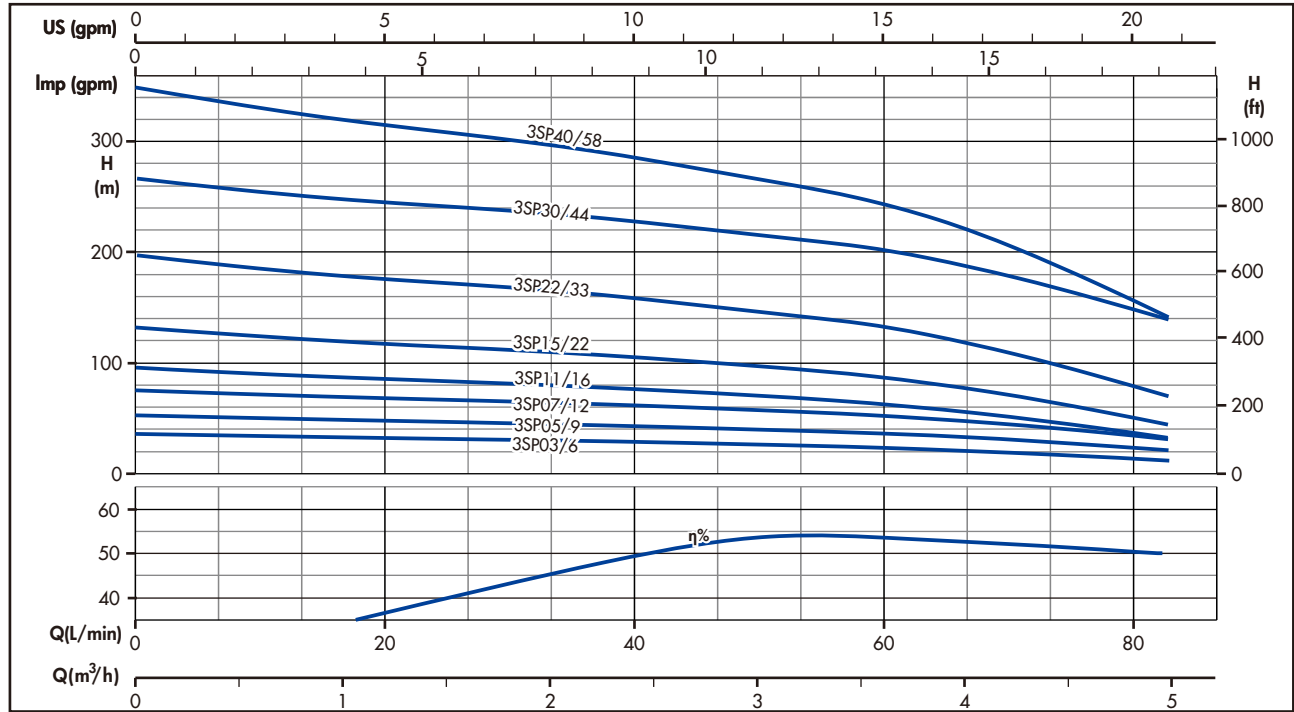

OPERATING CHARACTERISTICS AT 50 Hz

PUMP TYPE	No. OF STAGES	kW	Hp	Q=DELIVERY						
				L/min 0	17	34	40	50	60	83
				m³/h 0	1	2	2,4	3	3,6	5
				H=TOTAL HEAD METERS COLUMN OF WATER						
3SP03/6	6	0,37	0,5	36	32	30	29	26	24	12
3SP05/9	9	0,55	0,75	54	49	45	43	40	36	18
3SP07/12	12	0,75	1	72	65	60	58	53	48	24
3SP11/16	16	1,1	1,5	96	86	80	77	70	64	32
3SP15/22	22	1,5	2	132	119	110	106	97	88	44
3SP22/33	33	2,2	3	198	178	165	158	145	132	66
3SP30/44	44	3	4	264	238	220	211	194	176	88
3SP40/58	58	4	5,5	348	313	290	278	255	232	116

DIMENSIONS AND WEIGHTS AT 50 Hz

PUMP TYPE	No. OF STAGES	DN	L1 mm	PUMP WEIGHT kg
3SP03/6	6	Rp1"1/4	273	2,8
3SP05/9	9		336	3,5
3SP07/12	12		391	4,1
3SP11/16	16		483	4,8
3SP15/22	22		609	6,4
3SP22/33	33		840	8,8
3SP30/44	44		1071	11,4
3SP40/58	58		1365	14,6

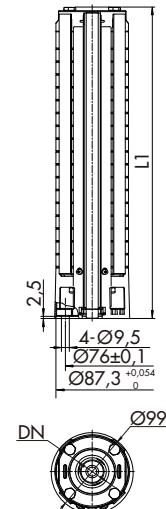

5SP SERIES

OPERATING CHARACTERISTICS AT 50 Hz

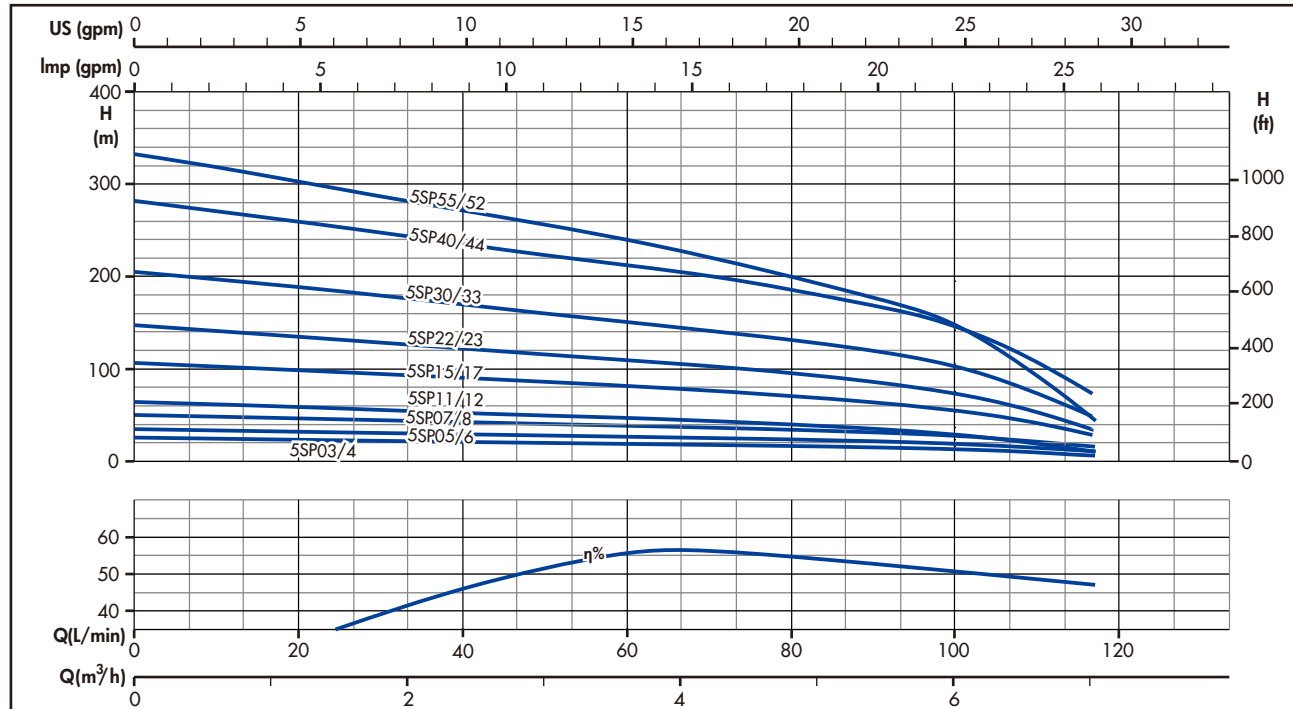

OPERATING CHARACTERISTICS AT 50 Hz

PUMP TYPE	No.OF STAGES	kW	Hp	Q=DELIVERY L/min 0 34 50 67 83 100 117 m³/h 0 2 3 4 5 6 7 H=TOTAL HEAD METERS COLUMN OF WATER						
				0	2	3	4	5	6	7
5SP03/4	4	0,37	0,5	26	22	20	19	16	13	6
5SP05/6	6	0,55	0,75	38	33	30	28	24	20	9
5SP07/8	8	0,75	1	51	44	40	38	32	26	12
5SP11/12	12	1,1	1,5	77	66	60	56	48	40	18
5SP15/17	17	1,5	2	109	94	85	80	68	56	26
5SP22/23	23	2,2	3	147	127	115	108	92	76	35
5SP30/33	33	3	4	211	182	165	155	132	109	50
5SP40/44	44	4	5,5	282	242	220	207	176	145	66
5SP55/52	52	5,5	7,5	333	286	260	244	208	172	78

DIMENSIONS AND WEIGHTS AT 50 Hz

PUMP TYPE	No.OF STAGES	DN	L1 mm	PUMP WEIGHT kg
5SP03/4	4	Rp1"1/2	235	2,3
5SP05/6	6		279	2,9
5SP07/8	8		323	3,3
5SP11/12	12		411	4,3
5SP15/17	17		521	5,5
5SP22/23	23		653	6,9
5SP30/33	33		873	9,5
5SP40/44	44		1115	12,4
5SP55/52	52	1291	14,4	

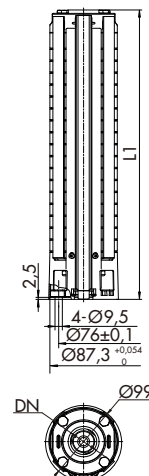

6SP SERIES

OPERATING CHARACTERISTICS AT 50 Hz

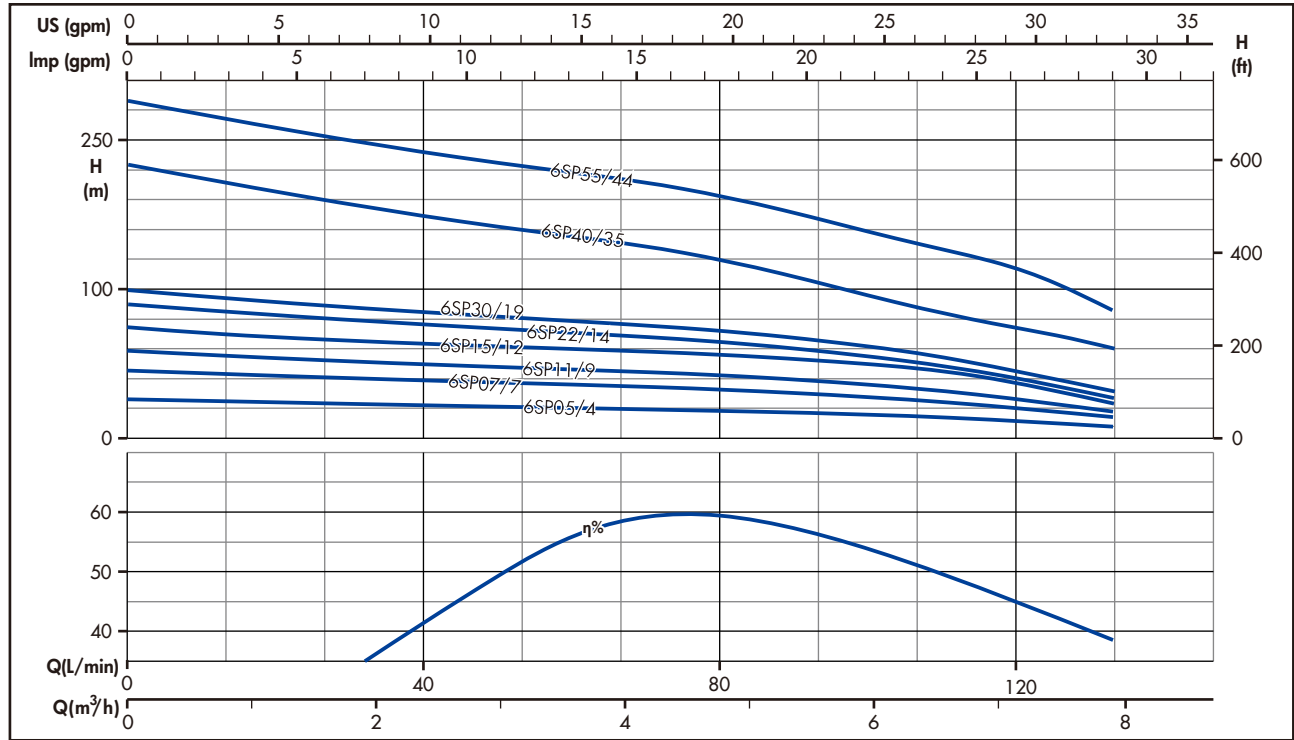

OPERATING CHARACTERISTICS AT 50 Hz

PUMP TYPE	No. OF STAGES	kW	Hp	Q=DELIVERY							
				L/min 0	50	67	80	100	120	133	
				m³/h 0 3 4 4,8 6 7,2 8							
				H=TOTAL HEAD METERS COLUMN OF WATER							
6SP05/5	5	0,55	0,75	33	27	25	24	20	15	10	
6SP07/7	7	0,75	1	46	37	35	33	28	21	14	
6SP11/10	10	1,1	1,5	65	53	50	47	40	30	20	
6SP15/12	12	1,5	2	78	64	60	58	48	36	24	
6SP22/15	15	2,2	3	98	80	75	71	60	45	30	
6SP30/21	21	3	4	137	111	105	99	84	63	42	
6SP40/35	35	4	5,5	228	186	175	165	140	105	70	
6SP55/44	44	5,5	7,5	286	233	220	207	176	132	88	

DIMENSIONS AND WEIGHTS AT 50 Hz

PUMP TYPE	No. OF STAGES	DN	L1 mm	PUMP WEIGHT kg
6SP05/5	5	Rp1"1/2	257	2,2
6SP07/7	7		301	3
6SP11/10	10		367	3,5
6SP15/12	12		411	4,2
6SP22/15	15		477	4,7
6SP30/21	21		609	6
6SP40/35	35		917	10,2
6SP55/44	44		1115	12,5

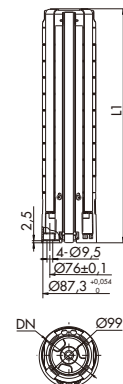

8SP SERIES

OPERATING CHARACTERISTICS AT 50 Hz

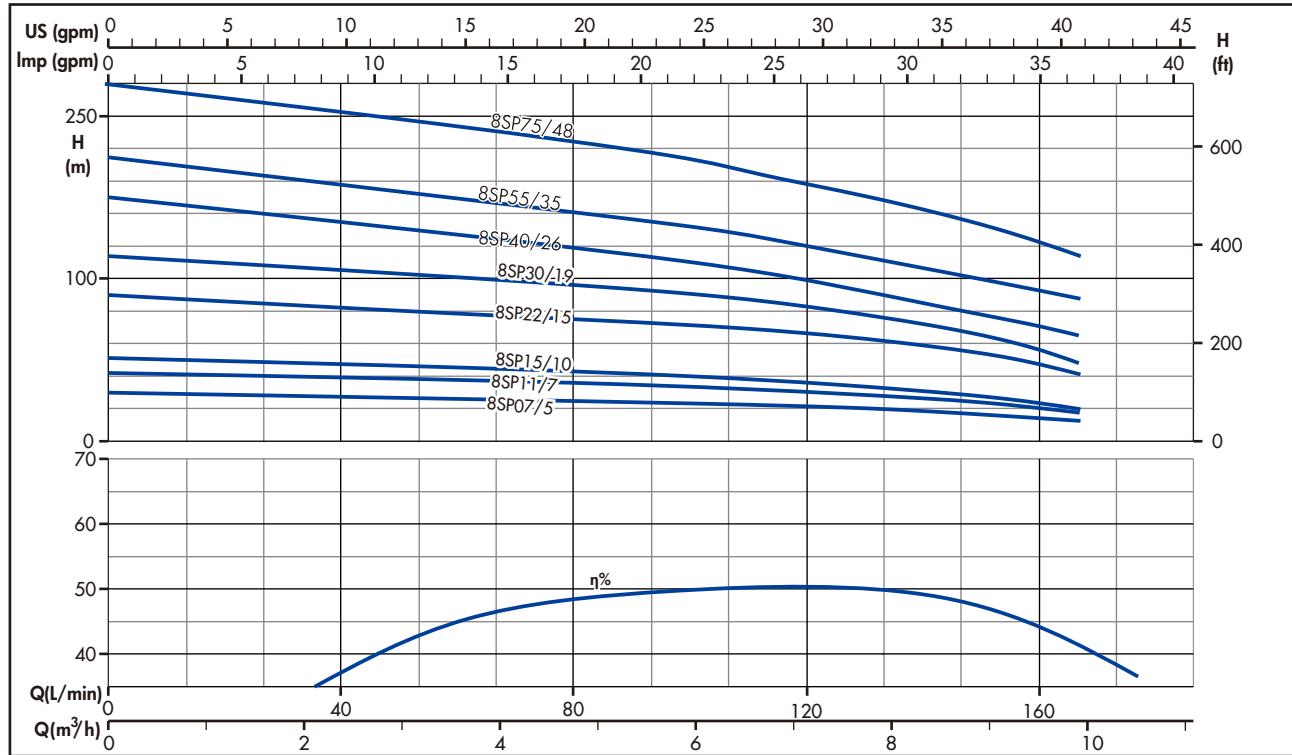

OPERATING CHARACTERISTICS AT 50 Hz

PUMP TYPE	No. OF STAGES	kW	Hp	Q=DELIVERY						
				L/min 0	50	83	107	133	160	167
				m³/h 0 3 5 6,4 8 9,6 10						
				H=TOTAL HEAD METERS COLUMN OF WATER						
8SP07/5	5	0,75	1	30	27	25	24	20	15	13
8SP11/7	7	1,1	1,5	42	37	34	33	28	21	18
8SP15/10	10	1,5	2	60	53	49	47	40	30	25
8SP22/15	15	2,2	3	90	80	74	71	60	45	38
8SP30/19	19	3	4	114	101	93	89	76	57	48
8SP40/26	26	4	5,5	156	138	127	122	104	78	65
8SP55/35	35	5,5	7,5	210	186	171	165	140	105	88
8SP75/48	48	7,5	10	288	254	235	226	192	144	120

DIMENSIONS AND WEIGHTS AT 50 Hz

PUMP TYPE	No. OF STAGES	DN	L1 mm	PUMP WEIGHT kg
8SP07/5	5	Rp2"	319	3,1
8SP11/7	7		375	3,7
8SP15/10	10		459	4,6
8SP22/15	15		599	6,1
8SP30/19	19		711	7,5
8SP40/26	26		907	9,6
8SP55/35	35		1159	12,3
8SP75/48	48		1523	16,2

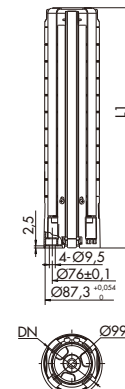

14SP SERIES

OPERATING CHARACTERISTICS AT 50 Hz

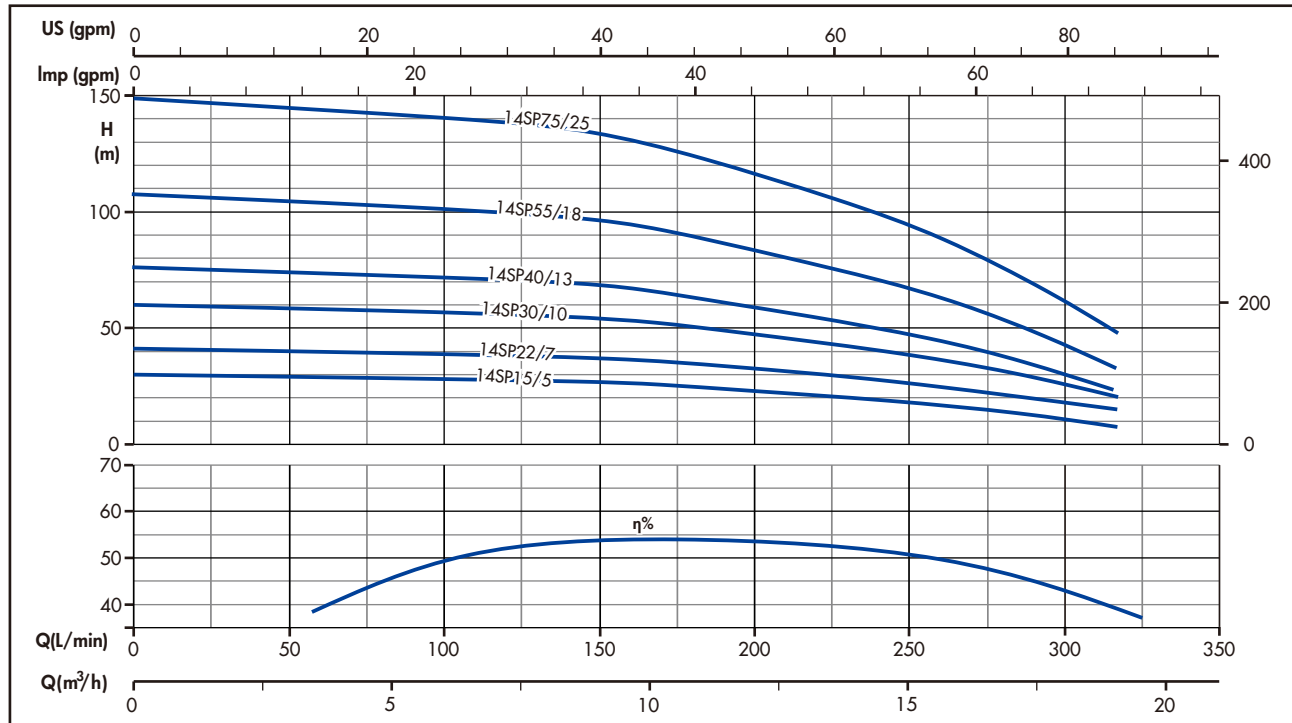

OPERATING CHARACTERISTICS AT 50 Hz

PUMP TYPE	No.OF STAGES	kW	Hp	Q=DELIVERY						
				L/min 0	133	167	183	233	283	317
				m³/h 0	8	10	11	14	17	19
H=TOTAL HEAD METERS COLUMN OF WATER										
14SP15/5	5	1,5	2	30	28	26	25	20	14	8
14SP22/7	7	2,2	3	42	39	36	34	28	20	11
14SP30/10	10	3	4	60	55	52	49	40	28	16
14SP40/13	13	4	5,5	78	72	68	64	52	36	21
14SP55/18	18	5,5	7,5	108	99	94	88	72	50	29
14SP75/25	25	7,5	10	150	138	130	123	100	70	40

DIMENSIONS AND WEIGHTS AT 50 Hz

PUMP TYPE	No.OF STAGES	DN	L1 mm	PUMP WEIGHT kg
14SP15/5	5	Rp2"	389	3,6
14SP22/7	7		473	4,6
14SP30/10	10		599	6,1
14SP40/13	13		725	7,6
14SP55/18	18		935	10,1
14SP75/25	25		1229	13,6

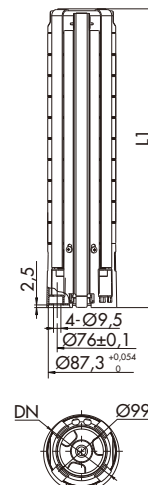

ACQUAJET SERIES 4" SUBMERSIBLE ELECTRIC PUMPS

- Advanced hydraulic model, compact structure
- Easy to move and install

APPLICATIONS

- Water supply from deep well.
- Pressure boosting.

SPECIFICATIONS

- Delivery: up to 8 m³/h at 2850 rpm.
- Head: up to 97 m at 2850 rpm.
- Maximum pump overall diameter (cable cover included): 99mm.
- Maximum permissible quantity of sand: 150 g/m³.
- Delivery port Rp1"1/4.

MOTOR POWER

Single-phase version:

from 0,37 to 1,1 kW, 220 V, 50 Hz.

Three-phase version:

from 0,37 to 1,1 kW, 380 V, 50 Hz.

CONSTRUCTION & CHARACTERISTICS

- Filling fluid in compliance with standards concerning oils contact with foodstuffs and with the purity requirements specified by the annex to G.U. no. 104 of 20/04/1973; it also complies with F.D.A. (FOOD AND DRUG ADMINISTRATION) standards.
- Large compensation bellows for the expansion of the internal liquid.
- Pump and motor connected inside complete pump sleeve, compact and aesthetic.
- Discharge made of engineering plastic pump sleeve and filter made of AISI304, makes pump corrosion resistant and portable.
- Inlet at bottom of pump, which makes pump get more water in case of low water level.
- Water flow around motor sleeve, carries away most heat generated by motor, which cools down motor, saves cost and prolongs motor life.

IDENTIFICATION CODE

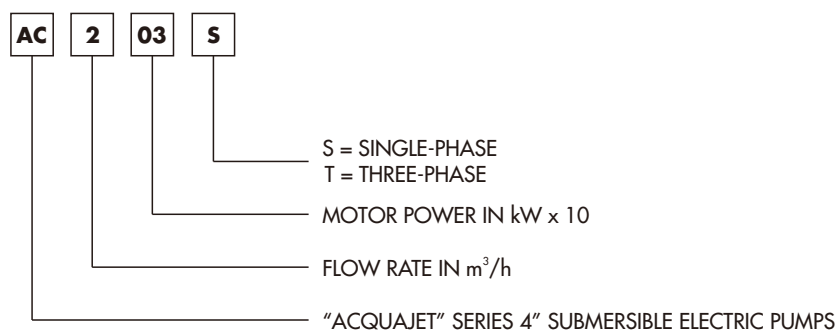

EXAMPLE OF PUMP TYPE

AC203S

ACQUAJET series 4" submersible electric pump with flow rate 2m³/h, single phase 0,37 kW(0,5 Hp) motor.



ACQUAJET SERIES

PUMP SECTION AND LIST OF MAIN COMPONENTS MATERIAL

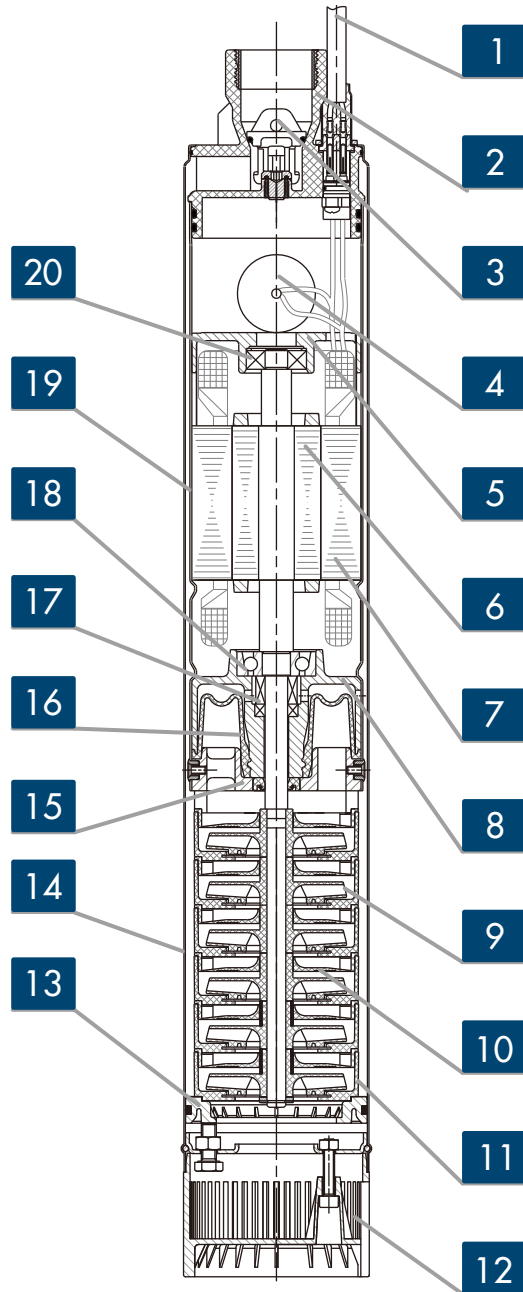

REF.N.	PART	MATERIAL	STANDARD
1	Cable	-----	-----
2	Discharge port	Noryl® PPO	-----
3	Non-return valve	ABS	-----
4	Capacitor(only single-phase)	-----	-----
5	Upper support	Cast iron	ASTM 200A
6	Rotor	-----	-----
7	Stator	-----	-----
8	Lower support	Aluminium alloy	-----
9	Impeller	ABS	-----
10	Diffuser	ABS	-----
11	Stage housing	ABS	-----
12	Filter	Noryl® PPO	-----
13	Locating plate	Noryl® PPO	-----
14	Pump sleeve	Stainless steel	AISI 304
15	Gland	Noryl® PPO	-----
16	Compensation bellow	NBR	-----
17	Mechanical seal	Carbon/Ceramic	-----
18	Bearing	-----	-----
19	Motor sleeve	Stainless steel	AISI 304
20	Bearing	-----	-----

ACQUAJET SERIES

OPERATING CHARACTERISTICS AT 50 Hz

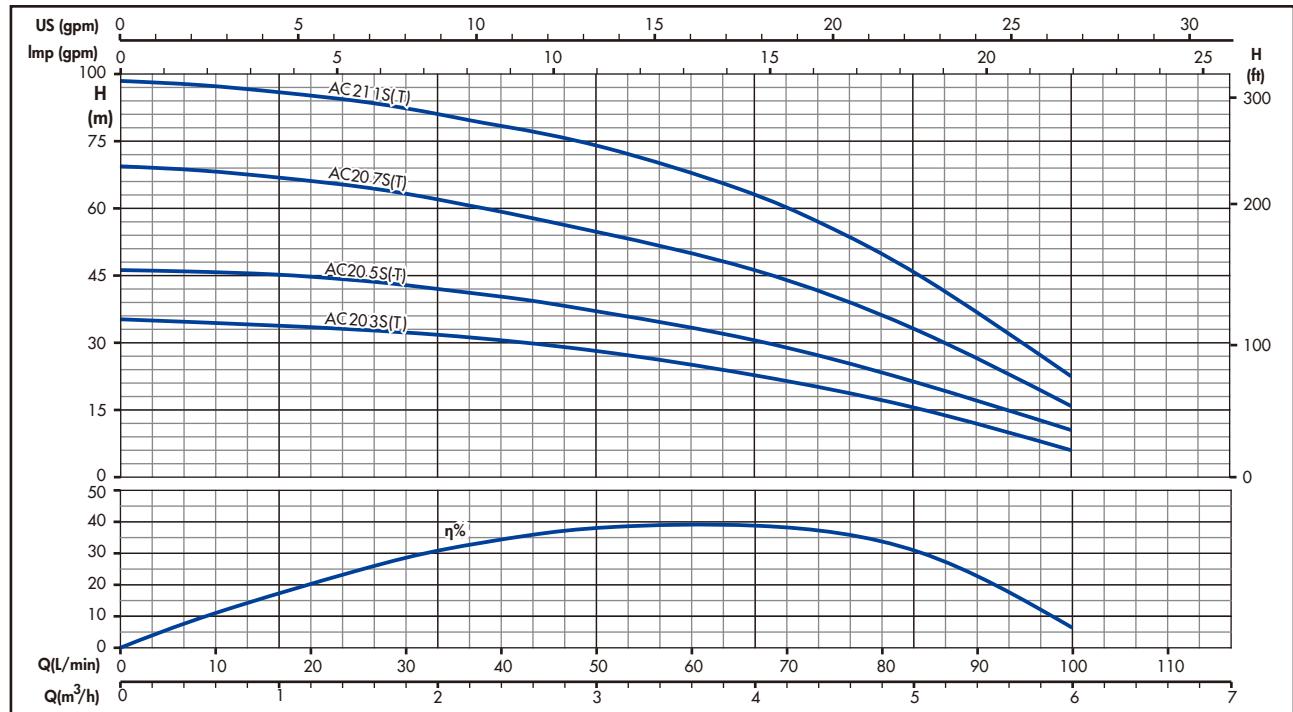

OPERATING CHARACTERISTICS AT 50 Hz

PUMP TYPE	kW	Hp	Q=DELIVERY							
			l/min 0	17	33	50	67	83	100	
			m³/h 0	1	2	3	4	5	6	
H=TOTAL HEAD METERS COLUMN OF WATER										
AC203S	0,37	0,5	35	34	32	28,5	23	16	6	
AC203T										
AC205S	0,55	0,75	46	45	42	37	30,5	22	10,5	
AC205T										
AC207S	0,75	1	69	67	62	55,5	46	33	16	
AC207T										
AC211S	1,1	1,5	97	92	85	72	63	47	22	
AC211T										

DIMENSIONS AND WEIGHTS AT 50 Hz

PUMP TYPE	No. OF STAGES	DN	L mm	PUMP WEIGHT kg
AC203S	5	Rp1"1/4	623,5	10,5
AC203T			561,5	8
AC205S	7		680,5	11,5
AC205T			630,5	9
AC207S	10		774	13
AC207T			717	10,5
AC211S	14		936	16
AC211T			851	10

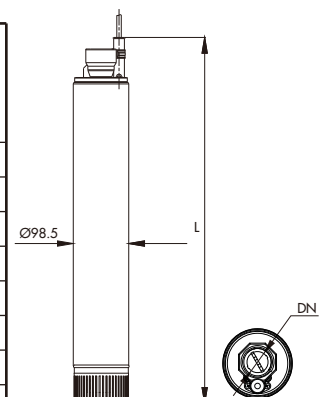

ACQUAJET SERIES

OPERATING CHARACTERISTICS AT 50 Hz

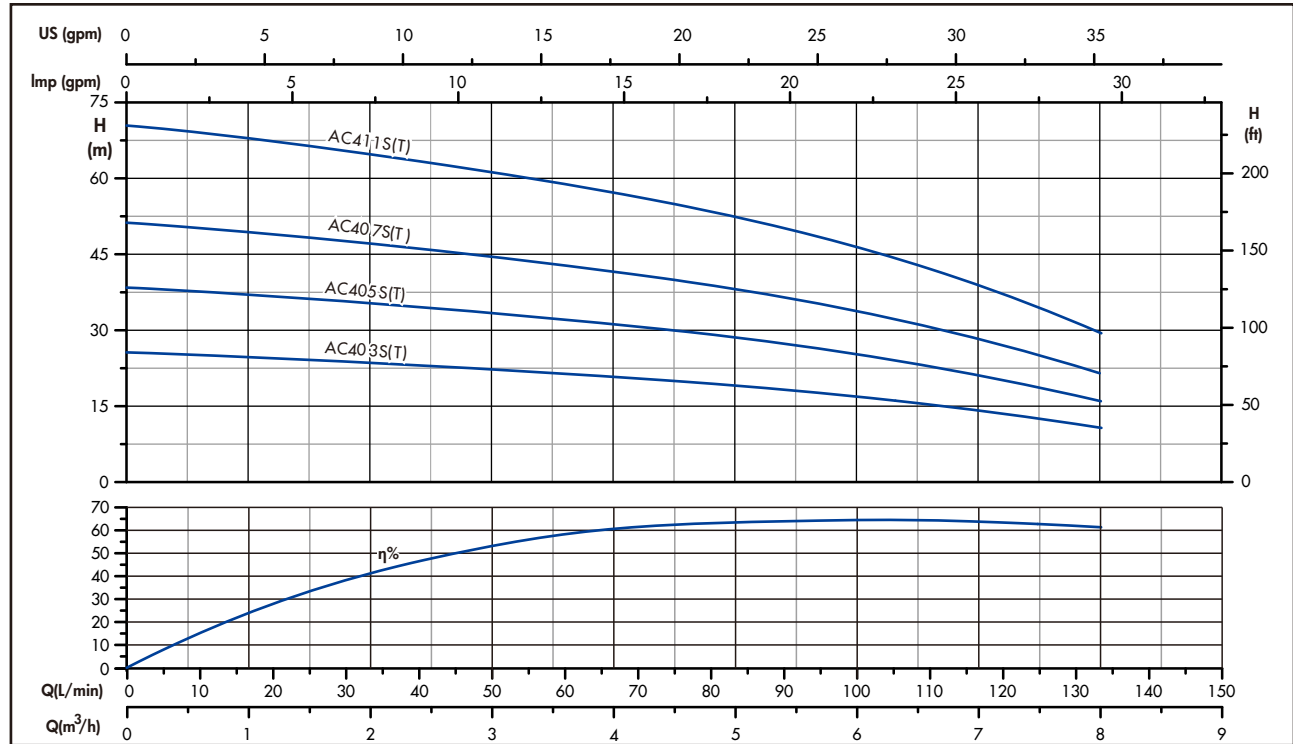

OPERATING CHARACTERISTICS AT 50 Hz

PUMP TYPE	kW	Hp	Q=DELIVERY							
			l/min 0	33	50	67	83	100	133	
			m³/h 0	2	3	4	5	6	8	
H=TOTAL HEAD METERS COLUMN OF WATER										
AC403S	0,37	0,5	25,5	23,5	22,5	20	19	17	11	
AC403T										
AC405S	0,55	0,75	38,5	35	33,5	30	28,5	25,5	16	
AC405T										
AC407S	0,75	1	51	47	44,5	40	38	34	21	
AC407T										
AC411S	1,1	1,5	70,5	65	61,5	55	52	46,5	29	
AC411T										

DIMENSIONS AND WEIGHTS AT 50 Hz

PUMP TYPE	No.OF STAGES	DN	L mm	PUMP WEIGHT kg
AC403S	4	Rp1"1/4	641	10,5
AC403T			576	8
AC405S	6		717	12
AC405T			662	9,5
AC407S	8		813	13,5
AC407T			743	11
AC411S	11		972	16,5
AC411T			872	10,5

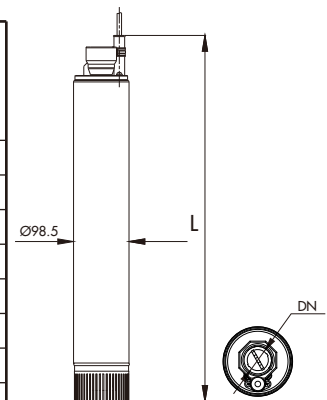

5OS SERIES 5" OIL-FILLED SUBMERSIBLE MOTORS

- The state-of-art design and choice of component materials ensure optimum operating performances, superior quality, reliability and ease of installation.

SPECIFICATIONS

- Shaft extension and couplings meet NEMA standards.
- Rewindable stator.
- Winding insulation: Class F .
- Protection grade: IP68.
- Filling fluid in compliance with standards concerning oils contact with foodstuffs and with the purity requirements specified by the annex to G.U. no. 104 of 20/04/1973; it also complies with F.D.A. (FOOD AND DRUG ADMINISTRATION) standards.
- Large compensation bellows for the expansion of the internal liquid.
- Oversized thrust bearings: Shaft supported by oversized angular bearings which can support thrust load up to 10000N.
- Mechanical seal with sand protection.
- Maximum immersion depth: 150 m .
- Maximum water temperature: 35°C.
- Max temperature applies to motors working in a installation capable of delivering a flow of water around the motor jacket of at least 0,16 m/s.
- Maximum number of starts per hour at regular intervals: 30 for direct start.
- Maximum allowable voltage fluctuations over the rated voltage: 380 V \pm 10 %.

MODELS

- Three-phase:
from 2,2 kW to 15 kW, 380 V, 50 Hz.

IDENTIFICATION CODE

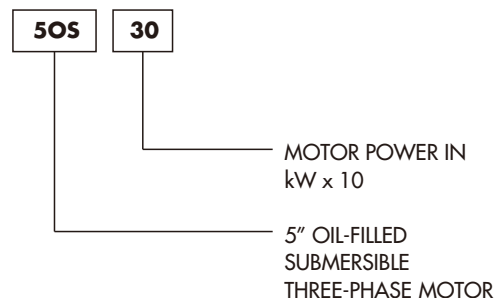

EXAMPLE OF MOTOR TYPE

5OS30

5" oil-filled submersible motor, three-phase, 3 kW (4 Hp).



50S SERIES MOTOR CROSS SECTION AND TABLE OF MATERIAL

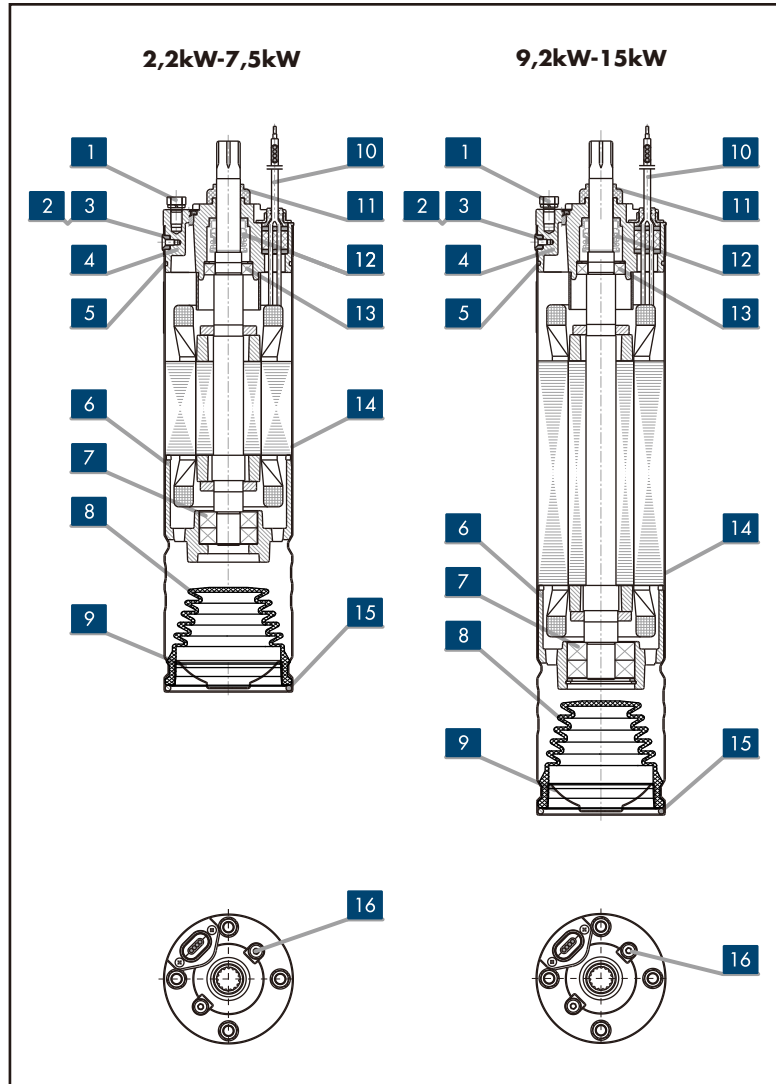

REF.N.	PART	MATERIAL	STANDARD
1	Double ends studs	Stainless steel	AISI 304
2	Pin	Stainless steel	AISI 304
3	Screw	Stainless steel	AISI 304
4	Upper support	Cast iron	ASTM 200A
5	O-ring	NBR	-----
6	Lower support	Cast iron	ASTM 200A
7	Angular bearing	-----	-----
8	Compensation bellow	NBR	-----
9	Lower protection	Stainless steel	AISI 304
10	Cable	-----	-----
11	Sand protection	NBR	-----
12	Mechanical seal	Carbon/Ceramic	-----
13	Ball bearing	-----	-----
14	Motor shell	Stainless steel	AISI 304
15	Snap ring	Stainless steel	AISI 304
16	Filling screw	Stainless steel	AISI 304

DIMENSIONS AND WEIGHTS AT 50 Hz

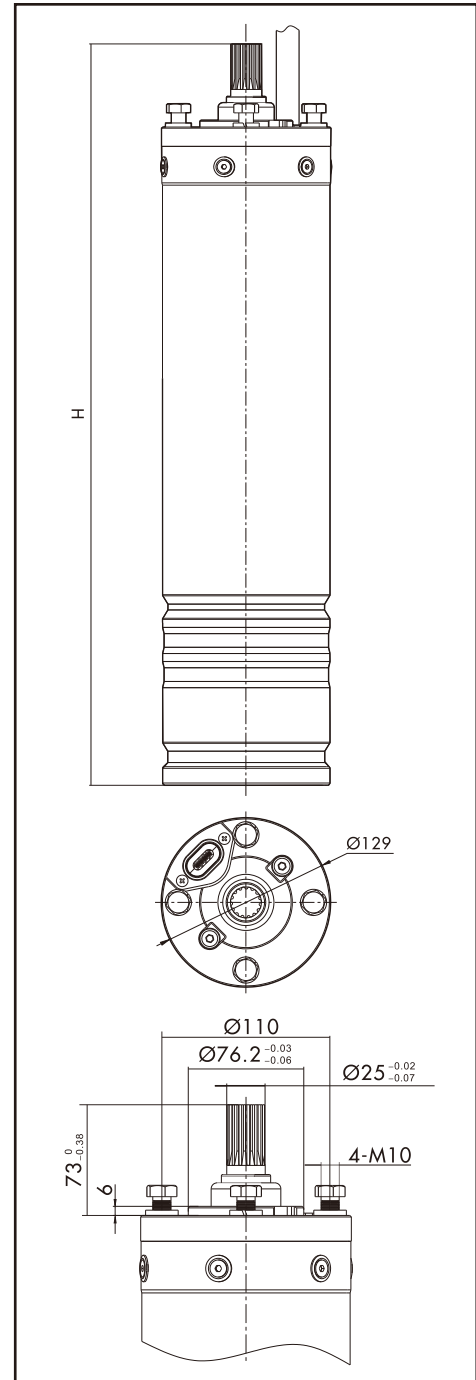

MOTOR TYPE	POWER		H mm	WEIGHT kg
	kW	Hp		
50S22	2,2	3	610,5	22,5
50S30	3	4	640,5	25
50S40	4	5,5	675,5	27,5
50S55	5,5	7,5	735,5	32,5
50S75	7,5	10	780,5	36
50S92	9,2	12,5	825	40
50S110	11	15	900	44,5
50S130	13	17,5	925	49
50S150	15	20	945	53

60S SERIES 6" OIL-FILLED SUBMERSIBLE MOTORS

- The state-of-art design and choice of component materials ensure optimum operating performances, superior quality, reliability and ease of installation.

SPECIFICATIONS

- Shaft extension and couplings meet NEMA standards.
- Rewindable stator.
- Winding insulation: Class F .
- Protection grade: IP68.
- Filling fluid in compliance with standards concerning oils contact with foodstuffs and with the purity requirements specified by the annex to G.U. no. 104 of 20/04/1973; it also complies with F.D.A. (FOOD AND DRUG ADMINISTRATION) standards.
- Large compensation bellows for the expansion of the internal liquid.
- Oversized thrust bearings: Shaft supported by oversized angular bearings which can support thrust load up to 10000N.
- Mechanical seal with sand protection.
- Maximum immersion depth: 150 m .
- Maximum water temperature: 35°C.
- Max temperature applies to motors working in a installation capable of delivering a flow of water around the motor jacket of at least 0,16 m/s.
- Maximum number of starts per hour at regular intervals: 30 for direct start.
- Maximum allowable voltage fluctuations over the rated voltage: $380\text{ V} \pm 10\%$.

MODELS

- Three-phase:
from 3 to 15 kW, 380 V, 50 Hz.

OPTIONAL FEATURES

- Different voltage and frequency.
- Different materials.

IDENTIFICATION CODE

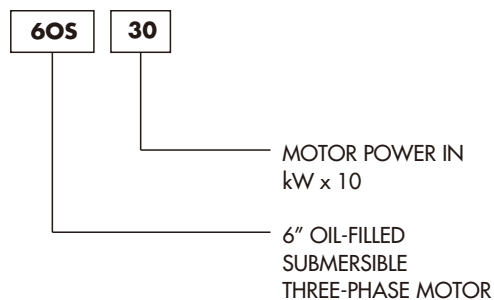

EXAMPLE OF MOTOR TYPE

60S30

6" oil-filled submersible motor, three-phase, 3 kW (4 Hp).



6OS SERIES MOTOR CROSS SECTION AND TABLE OF MATERIAL

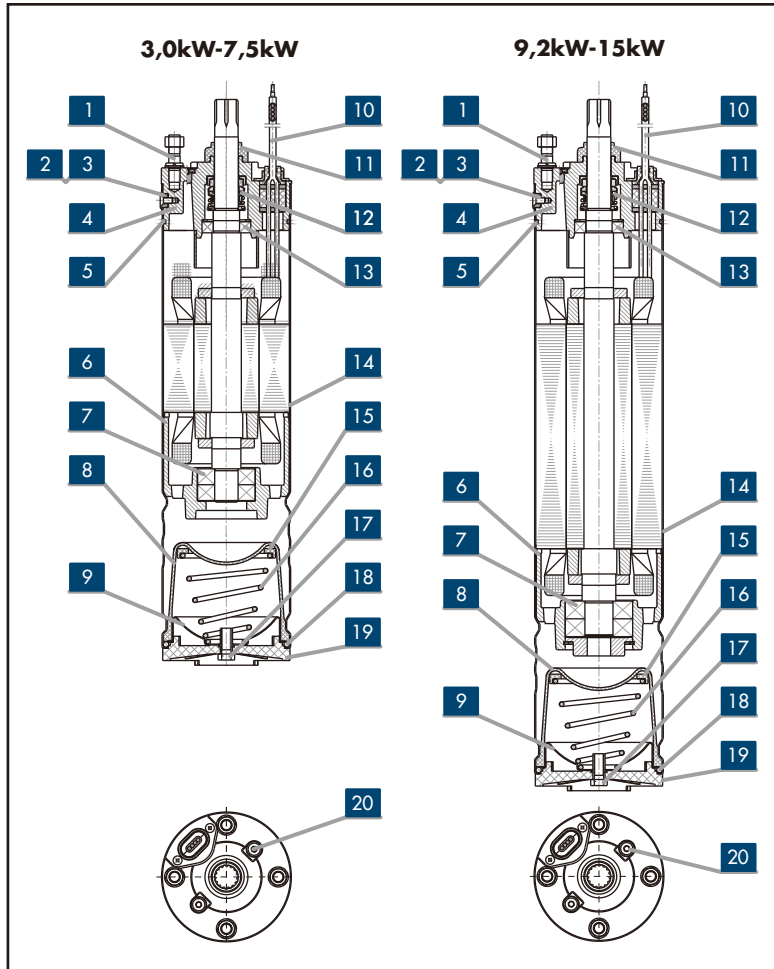

REF.N.	PART	MATERIAL	STANDARD
1	Double ends studs	Stainless steel	AISI 304
2	Pin	Stainless steel	AISI 304
3	Screw	Stainless steel	AISI 304
4	Upper support	Cast iron	ASTM 200A
5	O-ring	NBR	-----
6	Lower support	Cast iron	ASTM 200A
7	Angular bearing	-----	-----
8	Compensation bellow	NBR	-----
9	Lower protection	Stainless steel	AISI 304
10	Cable	-----	-----
11	Sand protection	NBR	-----
12	Mechanical seal	Carbon/Ceramic	-----
13	Ball bearing	-----	-----
14	Motor shell	Stainless steel	AISI 304
15	Spring base	PA66	-----
16	Spring	Stainless steel	-----
17	Bolt	Stainless steel	AISI 304
18	Snap ring	Stainless steel	AISI 304
19	Protection support	ABS	-----
20	Filling screw	Stainless steel	AISI 304

DIMENSIONS AND WEIGHTS AT 50 Hz

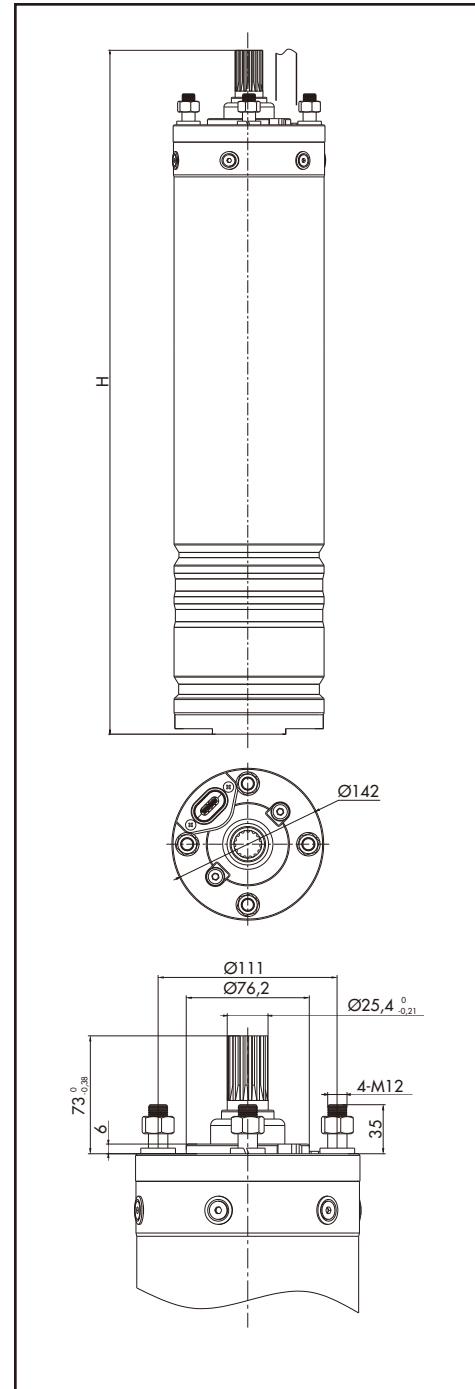

MOTOR TYPE	POWER		H mm	WEIGHT kg
	kW	Hp		
6OS30	3	4	605,5	27
6OS40	4	5,5	625,5	29
6OS55	5,5	7,5	655,5	32
6OS75	7,5	10	695,5	36
6OS92	9,2	12,5	738,5	41
6OS110	11	15	768,5	44
6OS130	13	17,5	798,5	46,5
6OS150	15	20	848,5	51,5

6OST SERIES 6" OIL-FILLED SUBMERSIBLE MOTORS

- The state-of-art design and choice of component materials ensure optimum operating performances, superior quality, reliability and ease of installation.

SPECIFICATIONS

- Shaft extension and couplings meet NEMA standards.
- Rewindable stator.
- Winding insulation: Class F .
- Protection grade: IP68.
- Filling fluid in compliance with standards concerning oils contact with foodstuffs and with the purity requirements specified by the annex to G.U. no. 104 of 20/04/1973; it also complies with F.D.A. (FOOD AND DRUG ADMINISTRATION) standards.
- Large compensation bellows for the expansion of the internal liquid.
- Oversized thrust bearings: Shaft supported by oversized angular bearings which can support thrust load up to 15500N.
- Mechanical seal with sand protection.
- Maximum immersion depth: 150 m .
- Maximum water temperature: 35°C.
- Max temperature applies to motors working in a installation capable of delivering a flow of water around the motor jacket of at least 0,16 m/s.
- Maximum number of starts per hour at regular intervals: 30 for direct start.
- Maximum allowable voltage fluctuations over the rated voltage: 380 V \pm 10 %.

MODELS

- Three-phase:
6OST : from 5, 5 to 37 kW, 380 V, 50 Hz.

OPTIONAL FEATURES

- Different voltage and frequency.
- Different materials.

IDENTIFICATION CODE

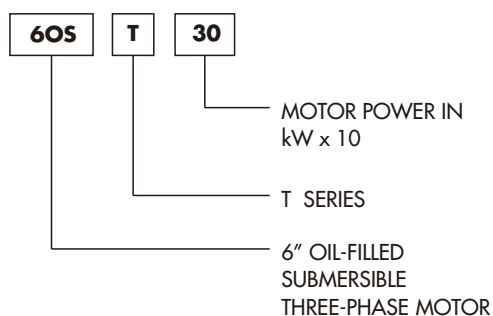

EXAMPLE OF MOTOR TYPE

6OST30

6" oil-filled submersible motor, T series, three-phase, 3 kW (4 Hp).



6OST SERIES MOTOR CROSS SECTION AND TABLE OF MATERIAL

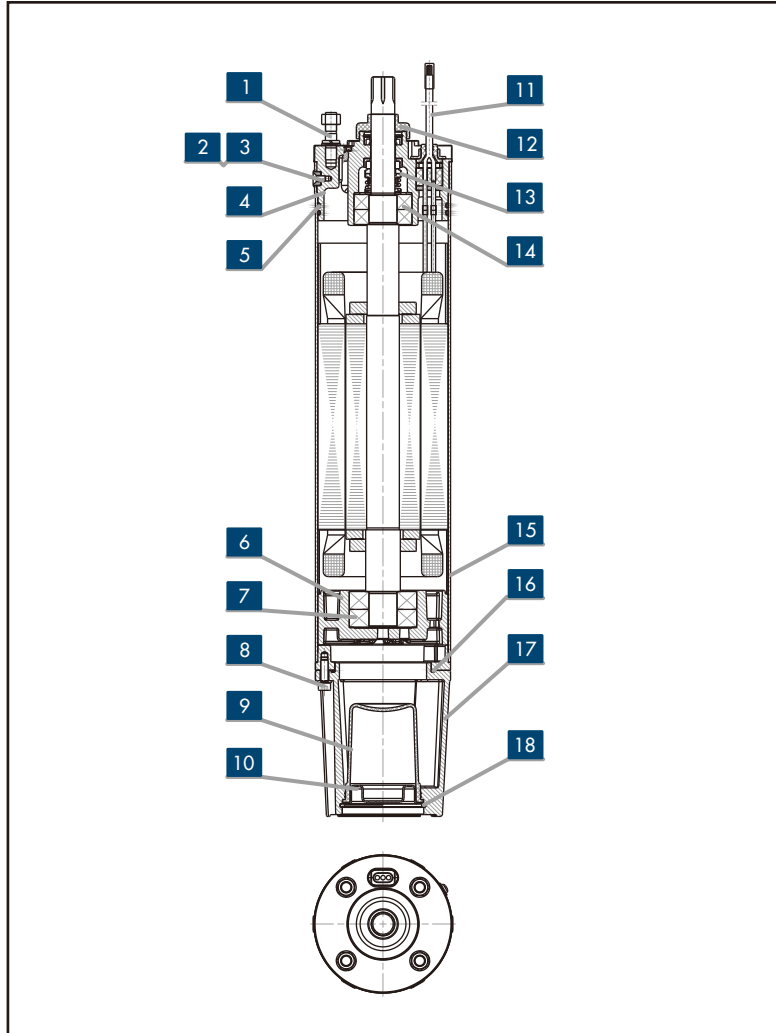

REF.N.	PART	MATERIAL	STANDARD
1	Double ends studs	Stainless steel	AISI 304
2	Pin	Stainless steel	AISI 304
3	Screw	Stainless steel	AISI 304
4	Upper support	Cast iron	ASTM 200A
5	O-ring	NBR	-----
6	Lower support	Cast iron	ASTM 200A
7	Angular bearing	-----	-----
8	Screw	Stainless steel	AISI 201
9	Compensation bellow	NBR	-----
10	Lower protection	Stainless steel	AISI 304
11	Cable	-----	-----
12	Sand protection	NBR	-----
13	Mechanical seal	Carbon/Ceramic	-----
14	Ball bearing	-----	-----
15	Motor shell	Stainless steel	AISI 304
16	O-ring	NBR	-----
17	Base	Cast iron	ASTM 200A
18	Snap ring	Stainless steel	AISI 304

DIMENSIONS AND WEIGHTS AT 50 Hz

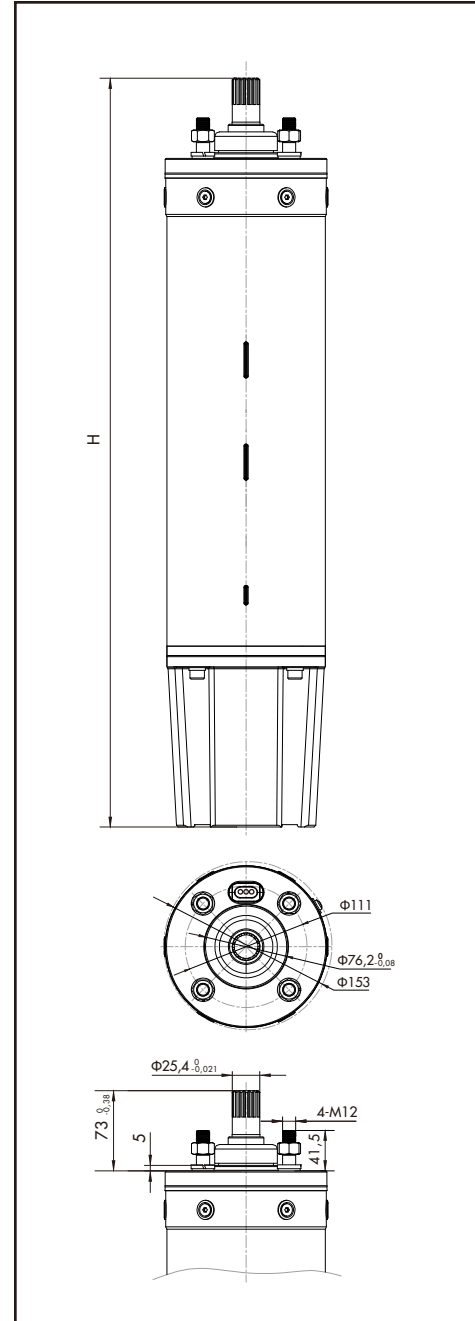

MOTOR TYPE	POWER		H mm	WEIGHT kg
	kW	Hp		
6OST55	5,5	7,5	694,5	42
6OST75	7,5	10	724,5	45,5
6OST92	9,2	12,5	739,5	48
6OST110	11	15	769,5	51,5
6OST130	13	17,5	794,5	54,5
6OST150	15	20	844,5	59
6OST185	18,5	25	864,5	61,5
6OST220	22	30	919,5	68,5
6OST250	25	35	954,5	72,5
6OST300	30	40	1024,5	81
6OST370	37	50	1114,5	92

OMSY6 SERIES 6" WATER-FILLED SUBMERSIBLE MOTORS

- The robust design and choice of component materials ensure optimum operating performances, superior quality, reliability and ease of installation.

SPECIFICATIONS

- Shaft extension and couplings meet NEMA standards.
- Rewindable stator.
- Protection grade: IP68.
- Standard compensation bellows for internal liquid expansion for regular operation.
- Oversized thrust bearings: Shaft supported by oversized thrust bearings which can support thrust load up to 20000 N.
- Filling fluid: water mixed with non-toxic anti-freeze glycol, provides cooling and lubrication, also protects and prevents parts inside from corrosion.
- Maximum immersion depth: 200 m .
- Maximum number of starts per hour at regular intervals: 10.
- Maximum allowable voltage fluctuations over the rated voltage: $\pm 10\%$.

VERSION

- Three-phase from 3 to 45 kW, 380 V/50 Hz.

OPTIONAL FEATURES

- Different voltage and frequency.
- Different material.
- Motors with double cable outlets for star/delta start.



IDENTIFICATION CODE

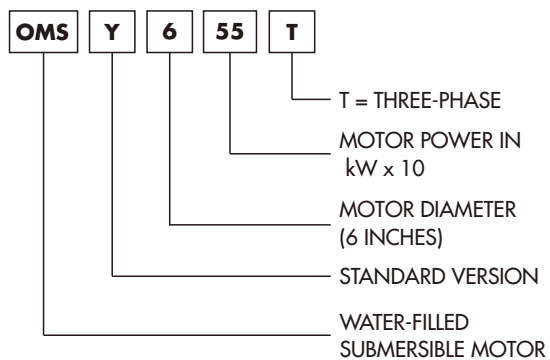

EXAMPLE OF MOTOR TYPE

OMSY655T

6" water-filled submersible motor, standard version, three-phase, 5,5kW (7.5HP).

OMSY6 SERIES MOTOR CROSS SECTION AND TABLE OF MATERIAL

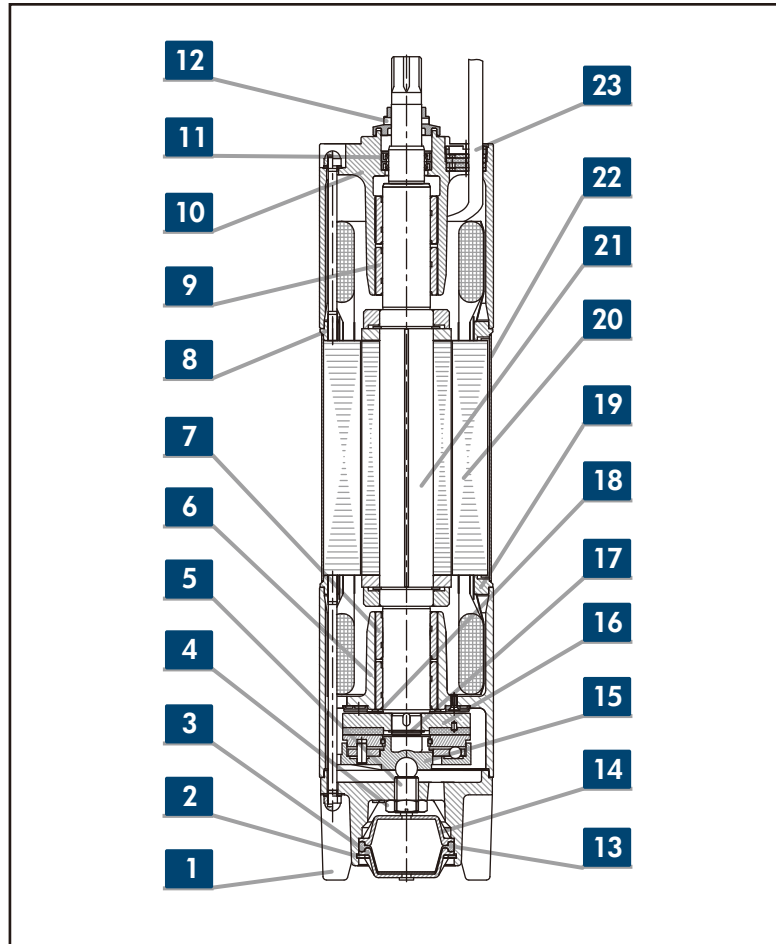

REF.N.	PART	MATERIAL	STANDARD
1	Base	Cast iron	ASTM 35A
2	Snap ring	Steel	----
3	Cover	Cast iron	ASTM 20A
4	Nut	Steel	----
5	Screw	Steel	----
6	Lower support	Cast iron	ASTM 30A
7	Bush bearing	Graphite	----
8	Upper flange	Stainless steel	AISI 304
9	Bush bearing	Graphite	----
10	Upper support	Cast iron	ASTM 30A
11	Lip seal	----	----
12	Sand protection	Stainless steel	----
13	Compensation bellow	NBR	----
14	Cover	----	----
15	Thrust bearing	----	----
16	Thrust disk	----	----
17	Ring	Steel	----
18	Plate	----	----
19	Lower flange	Stainless steel	AISI 304
20	Stator	----	----
21	Rotor	----	----
22	Motor casing	Stainless steel	----
23	Cable	----	----

DIMENSIONS AND WEIGHTS AT 50 Hz

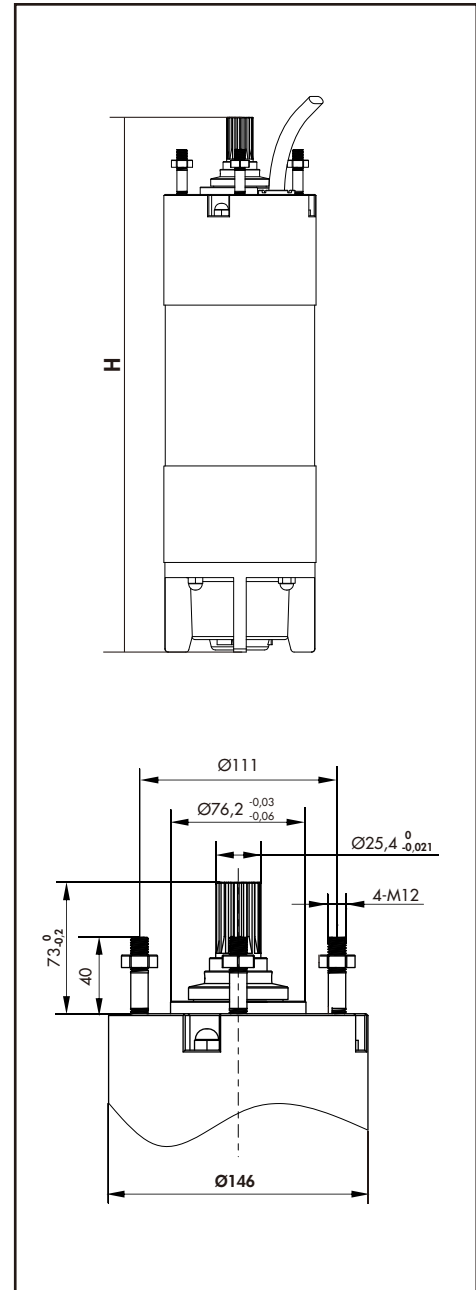

MOTOR TYPE	RATED POWER		H mm	WEIGHT kg
	kW	Hp		
OMSY630T	3	4	654	39
OMSY640T	4	5,5	684	43
OMSY655T	5,5	7,5	684	43
OMSY675T	7,5	10	704	45
OMSY692T	9,2	12,5	754	50
OMSY6110T	11	15	764	53
OMSY6130T	13	17,5	794	56
OMSY6150T	15	20	874	65
OMSY6185T	18,5	25	934	73
OMSY6220T	22	30	1019	83
OMSY6250T	25	34	1084	90
OMSY6300T	30	40	1169	100
OMSY6370T	37	50	1334	118
OMSY6450T	45	60	1394	125

OMSJ6 SERIES 6" WATER-FILLED SUBMERSIBLE MOTORS

- The robust design and choice of component materials ensure optimum operating performances, superior quality, reliability and ease of installation.

SPECIFICATIONS

- Shaft extension and couplings meet NEMA standards.
- Rewindable stator.
- Protection grade: IP68.
- Bigger compensation bellows for internal liquid expansion for severe operation condition.
- Oversized thrust bearings: Shaft supported by oversized thrust bearings which can support thrust load up to 20000 N.
- Mechanical seal: reliable, long service, more resistant to sand.
- Filling fluid: water mixed with non-toxic anti-freeze glycol, provides cooling and lubrication, also protects and prevents parts inside from corrosion.
- Maximum immersion depth: 200 m .
- Maximum number of starts per hour at regular intervals: 10.
- Maximum allowable voltage fluctuations over the rated voltage: $\pm 10\%$.

VERSION

- Three-phase from 3 to 45 kW, 380 V/50 Hz.

OPTIONAL FEATURES

- Different voltage and frequency.
- Different material.
- Motors with double cable outlets for star/delta start.



IDENTIFICATION CODE

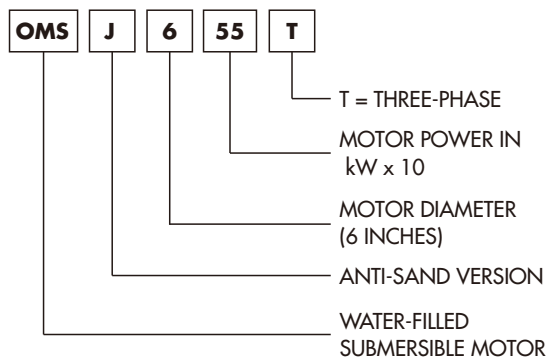

EXAMPLE OF MOTOR TYPE

OMSJ655T

6" water-filled submersible motor, anti-sand version, three-phase, 5,5kW(7.5HP).

OMSJ6 SERIES

MOTOR CROSS SECTION AND TABLE OF MATERIAL

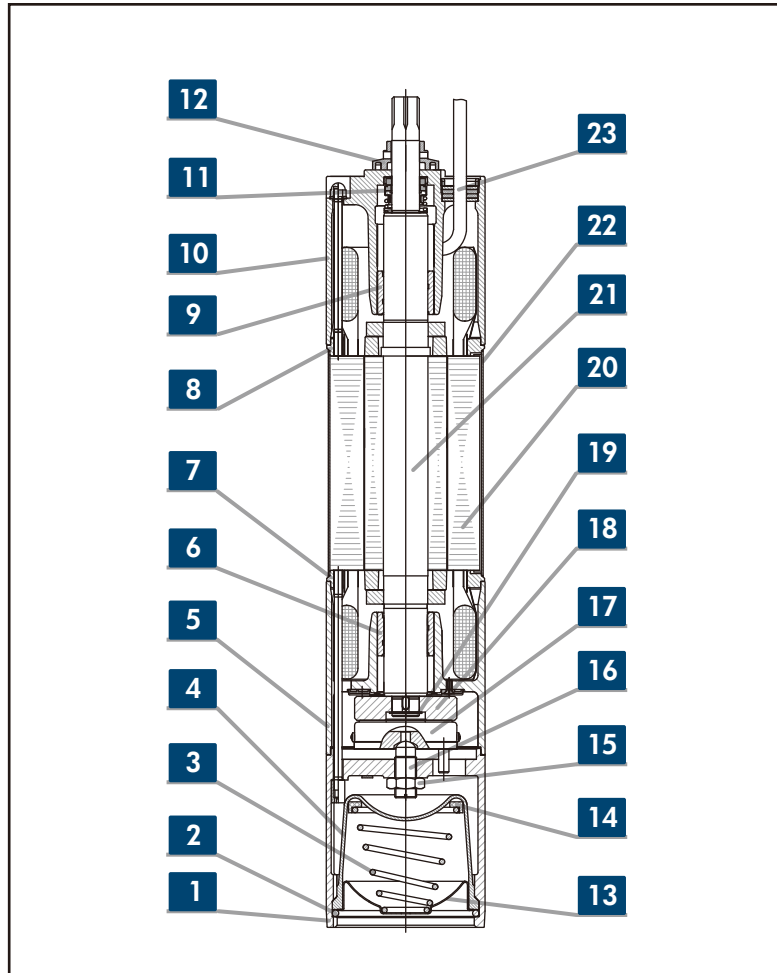

REF.N.	PART	MATERIAL	STANDARD
1	Base	Cast iron	ASTM 35A
2	Snap ring	Stainless steel	AISI 304
3	Conical spring	Stainless steel	AISI 304
4	Compensation bellow	NBR	----
5	Lower support	Cast iron	ASTM 30A
6	Bush bearing	Graphite	----
7	Upper flange	Stainless steel	AISI 304
8	Upper flange	Stainless steel	AISI 304
9	Bush bearing	Graphite	----
10	Upper support	Cast iron	ASTM 30A
11	Mechanical seal	----	----
12	Sand protection	Stainless steel	----
13	Gland	Stainless steel	AISI 304
14	Tower spring seat	----	----
15	Nut	Steel	----
16	Ball Screw	Steel	----
17	Thrust bearing	----	----
18	Thrust disk	----	----
19	Ring	Stainless steel	AISI 304
20	Stator	----	----
21	Rotor	----	----
22	Motor casing	Stainless steel	----
23	Cable	----	----

DIMENSIONS AND WEIGHTS AT 50 Hz

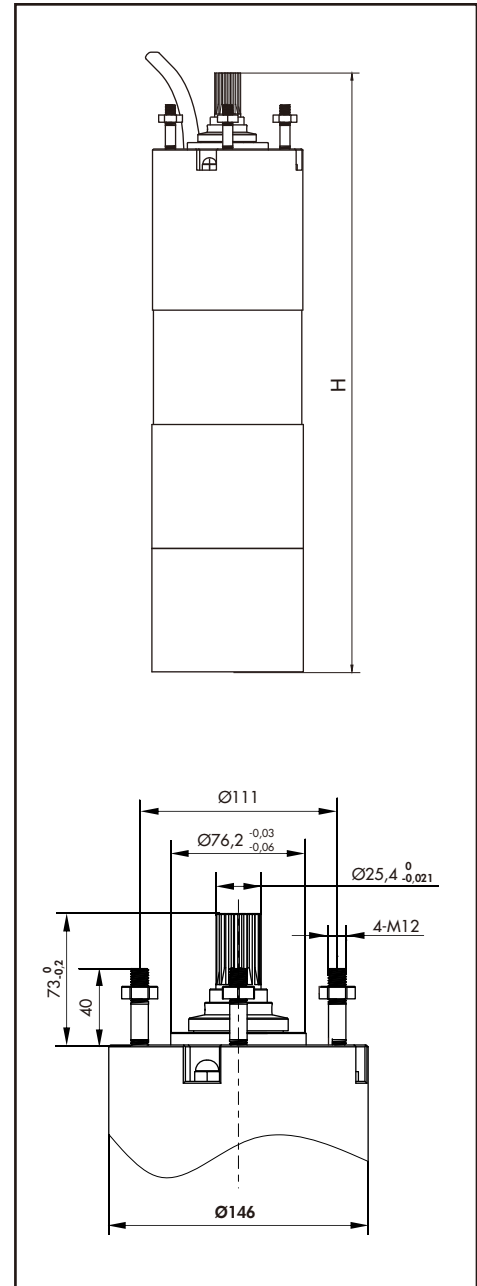

MOTOR TYPE	RATED POWER		H mm	WEIGHT kg
	kW	Hp		
OMSJ630T	3	4	726,4	41
OMSJ640T	4	5,5	756,4	45
OMSJ655T	5,5	7,5	756,4	45
OMSJ675T	7,5	10	776,4	47
OMSJ692T	9,2	12,5	826,4	52
OMSJ6110T	11	15	836,4	55
OMSJ6130T	13	17,5	866,4	58
OMSJ6150T	15	20	946,4	67
OMSJ6185T	18,5	25	1006,4	75
OMSJ6220T	22	30	1091,4	85
OMSJ6250T	25	34	1156,4	92
OMSJ6300T	30	40	1241,4	102
OMSJ6370T	37	50	1406,4	120
OMSJ6450T	45	60	1466,4	127

OMSY8 SERIES 8" WATER-FILLED SUBMERSIBLE MOTORS

- The robust design and choice of component materials ensure optimum operating performances, superior quality, reliability and ease of installation.

SPECIFICATIONS

- Shaft extension and couplings meet NEMA standards.
- Rewindable stator.
- Protection grade: IP68.
- Standard compensation bellows for internal liquid expansion for regular operation.
- Oversized thrust bearings: Shaft supported by oversized thrust bearings which can support thrust load up to 60000 N.
- Filling fluid: water mixed with non-toxic anti-freeze glycol, provides cooling and lubrication, also protects and prevents parts inside from corrosion.
- Maximum immersion depth: 200 m .
- Maximum number of starts per hour at regular intervals: 10.
- Maximum allowable voltage fluctuations over the rated voltage: $\pm 10\%$.

VERSION

- Three-phase from 22 to 90 kW, 380 V/50 Hz.

OPTIONAL FEATURES

- Different voltage and frequency.
- Different material.
- Motors with double cable outlets for star/delta start.



IDENTIFICATION CODE

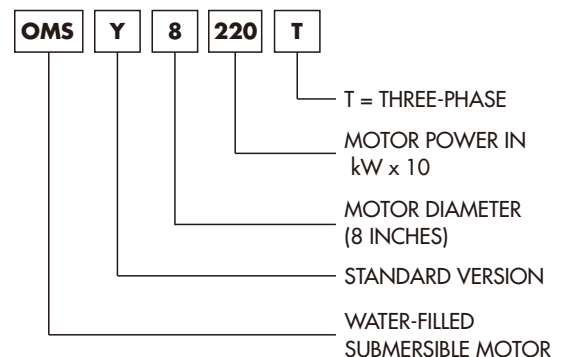

EXAMPLE OF MOTOR TYPE

OMSY8220T

8" water-filled submersible motor, standard version, three-phase, 22kW (30HP).

OMSY8 SERIES

DIMENSIONS AND WEIGHTS AT 50 Hz

MOTOR CROSS SECTION AND TABLE OF MATERIAL

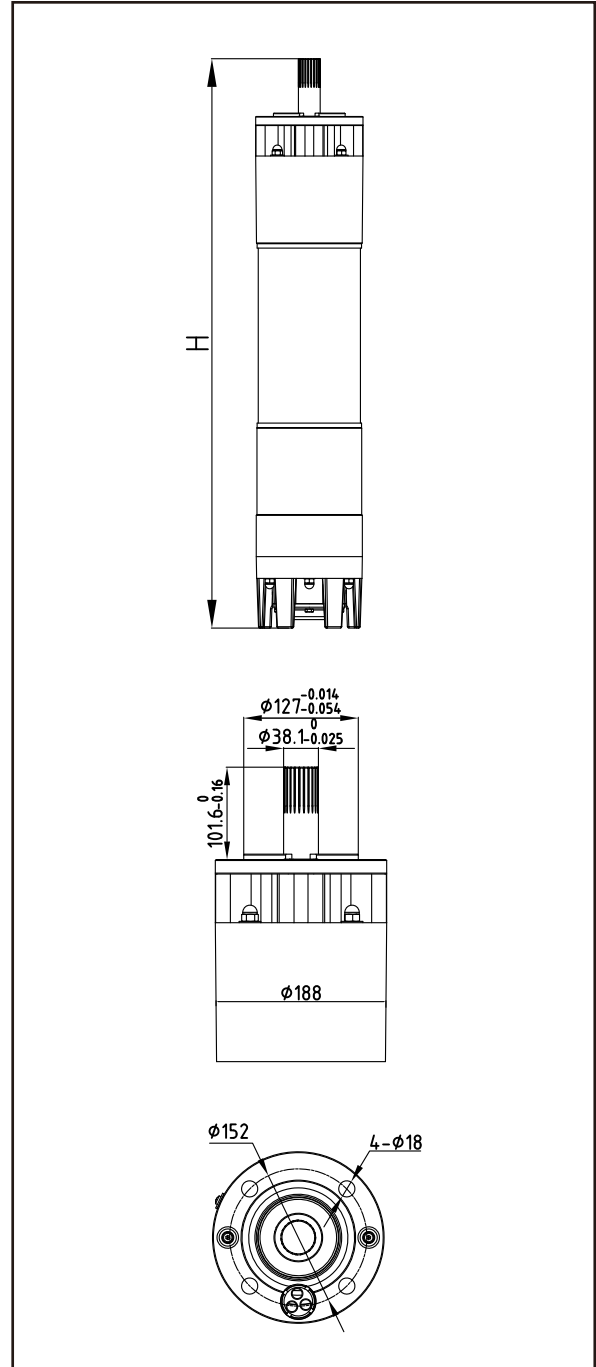
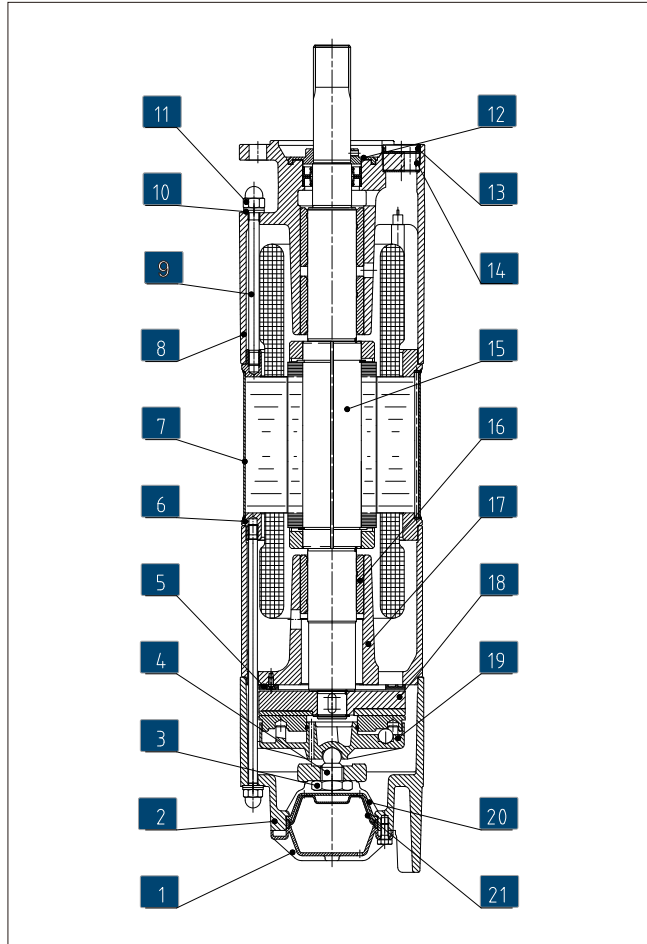

REF.N.	PART	MATERIAL	STANDARD
1	Cover	Cast iron	ASTM A48 Grade 250
2	Base	Cast iron	ASTM A48 Grade 250
3	Nut	Stainless Steel	AISI 304
4	Screw	Stainless Steel	AISI 304
5	Striker disk	Resine	----
6	Seal gasker	Oil-resistant fiber paper	----
7	Stator	Magn.sheet iron	----
8	Upper support	Cast iron	ASTM A48 Grade 250
9	Stud	Stainless steel	AISI 304
10	Washer	Brass	----
11	Nut	Stainless Steel	AISI 304
12	Sand protection	Stainless steel	AISI 420
13	Ring nut	Stainless steel	AISI 304
14	Gland	Rubber	----
15	Rotor	Magn.sheet iron	----
16	Bush bearing	Graphite	----
17	Lower support	Cast iron	ASTM A48 Grade 250
18	Thrust disk	Resine	----
19	Thrust bearing	Cast iron+Stainless steel	----
20	Cover	Stainless steel	----
21	Membrane	Rubber	----

MOTOR TYPE	POWER		In A	η %	COS Φ	H mm	WEIGHT kg
	kW	Hp					
OMSY8220T	22	30	48,5	83	0,83	998	119
OMSY8300T	30	40	65,4	84	0,83	1098	135
OMSY8370T	37	50	78,7	85	0,84	1218	155
OMSY8450T	45	60	95,8	85	0,84	1298	170
OMSY8550T	55	75	116,4	85,5	0,84	1398	191
OMSY8660T	66	90	139,6	85,5	0,84	1548	219
OMSY8750T	75	100	156,8	85,5	0,85	1648	229
OMSY8900T	90	120	187,1	86	0,85	1748	238

OMSJ8 SERIES 8" WATER-FILLED SUBMERSIBLE MOTORS

- The robust design and choice of component materials ensure optimum operating performances, superior quality, reliability and ease of installation.

SPECIFICATIONS

- Shaft extension and couplings meet NEMA standards.
- Rewindable stator.
- Protection grade: IP68.
- Bigger compensation bellows for internal liquid expansion for severe operation condition.
- Oversized thrust bearings: Shaft supported by oversized thrust bearings which can support thrust load up to 60000 N.
- Mechanical seal: reliable, long service, more resistant to sand.
- Filling fluid: water mixed with non-toxic anti-freeze glycol, provides cooling and lubrication, also protects and prevents parts inside from corrosion.
- Maximum immersion depth: 200 m .
- Maximum number of starts per hour at regular intervals: 10.
- Maximum allowable voltage fluctuations over the rated voltage: $\pm 10\%$.

VERSION

- Three-phase from 22 to 90 kW, 380 V/50 Hz.

OPTIONAL FEATURES

- Different voltage and frequency.
- Different material.
- Motors with double cable outlets for star/delta start.



IDENTIFICATION CODE

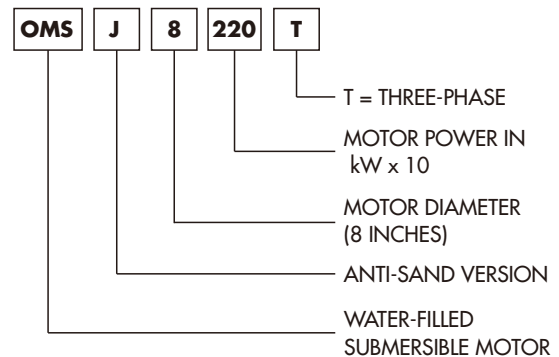

EXAMPLE OF MOTOR TYPE

OMSJ8220T

8" water-filled submersible motor, anti-sand version , three-phase, 22kW(30HP).

OMSJ8 SERIES MOTOR CROSS SECTION AND TABLE OF MATERIAL

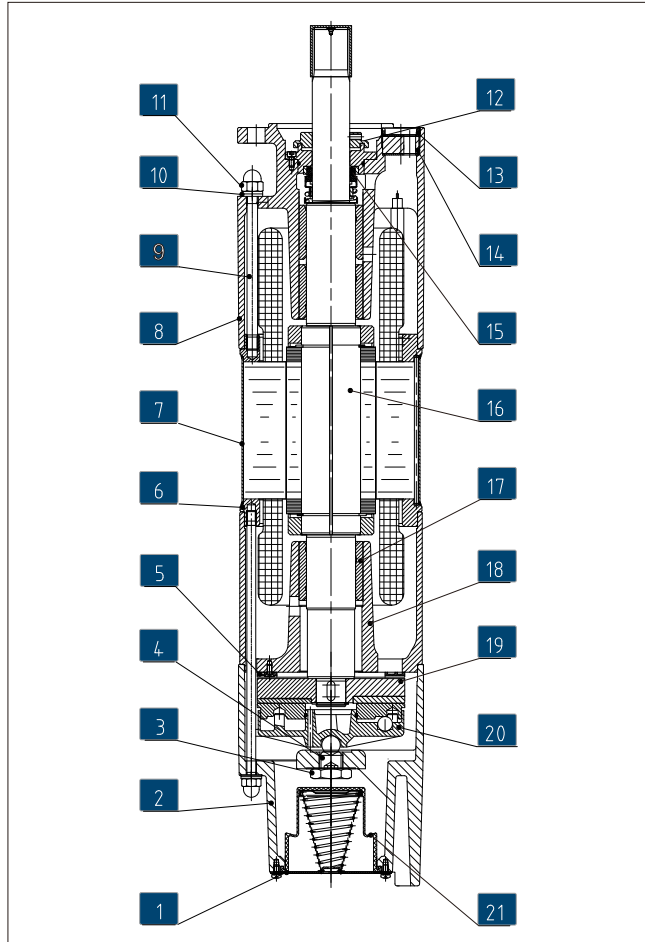

REF.N.	PART	MATERIAL	STANDARD
1	Cover	Cast iron	AISI 304
2	Base	Cast iron	ASTM A48 Grade 250
3	Nut	Stainless Steel	AISI 304
4	Screw	Stainless Steel	AISI 304
5	Striker disk	Resine	----
6	Seal gasker	Oil-resistant fiber paper	----
7	Stator	Magn.sheet iron	----
8	Upper support	Cast iron	ASTM A48 Grade 250
9	Stud	Stainless steel	AISI 304
10	Washer	Brass	----
11	Nut	Stainless Steel	AISI 304
12	Sand protection	Stainless steel	AISI 420
13	Ring nut	Stainless steel	AISI 304
14	Gland	Rubber	----
15	Mechanical seal	----	----
16	Rotor	Magn.sheet iron	----
17	Bush bearing	Graphite	ASTM A48 Grade 250
18	Lower support	Cast iron	----
19	Thrust disk	Resine	----
20	Thrust bearing	Cast iron+Stainless steel	----
21	Membrane	Rubber	----

DIMENSIONS AND WEIGHTS AT 50 Hz

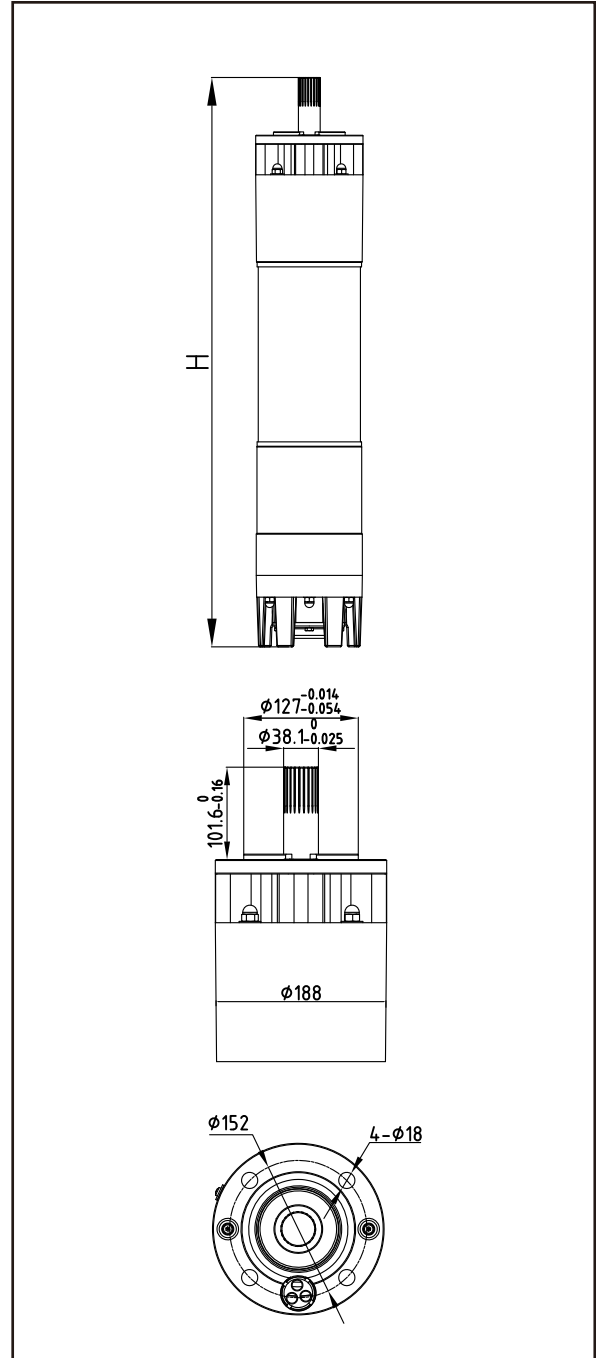

MOTOR TYPE	POWER		I _n A	η %	COSΦ	H	
	kW	Hp				mm	kg
OMSJ8220T	22	30	48,5	83	0,83	1023	122
OMSJ8300T	30	40	65,4	84	0,83	1123	138
OMSJ8370T	37	50	78,7	85	0,84	1243	158
OMSJ8450T	45	60	95,8	85	0,84	1323	173
OMSJ8550T	55	75	116,4	85,5	0,84	1423	194
OMSJ8660T	66	90	139,6	85,5	0,84	1573	222
OMSJ8750T	75	100	156,8	86	0,85	1673	232
OMSJ8900T	90	120	187,1	86	0,85	1773	241

TH SERIES 5" SUBMERSIBLE PUMPS

APPLICATIONS

- water supply from deep well
- Agricultural irrigation
- pressure boosting

CONSTRUCTION&CHARACTERISTICS

- Sturdy and lightweight, easy to disassemble and resistant to corrosion in non-aggressive environments.
- The delivery port and lower support are made of precision-caststainless steel, ensuring resistance to corrosion, durability and a sturdy coupling to the motor
- The impellers and diffusers are made of Noryl® PPO.
- The hexagonal pump shaft guarantees an effective impeller driving.
- A stainless steel non-return valve is fitted in the discharge to prevent back flow of water and alleviate water hammer to the pump,safeguarding impellers and diffusers.
- The guide bearings made of special TPU, ensure high resistance to wear and guarantee the constant and long-lasting using.
- Coupling and flange mounting dimensions meet NEMA standards.
- Simple maintenance, rapid installation and dismantling.
- Standard and special versions available.

SPECIFICATIONS

- Delivery: up to 40 m³/h;
- Head: up to 454 m at 2850rpm;
- Maximum pump overall diameter(cable guard included): 133mm;
- Maximum immersion depth: 150m;
- Solid content of pumped liquid on volume: ≤0,01%;
- Pumped liquid temperature: 0 ~ 35°C ;
- Pumped liquid PH: 6,5-8,5;
- Chlorine content of pumped liquid: 400mg/L;
- Hydrogen sulfide content of pumped liquid: ≤1,5mg/L.

OPTIONAL FEATURES

- Different voltage and frequency.
- Dual cable outlet for star/delta starting.
- Cast iron lower support and delivery port (2,2 kW to 15 kW)



TH SERIES

HYDRAULIC PERFORMANCE RANGE AT 50 HZ

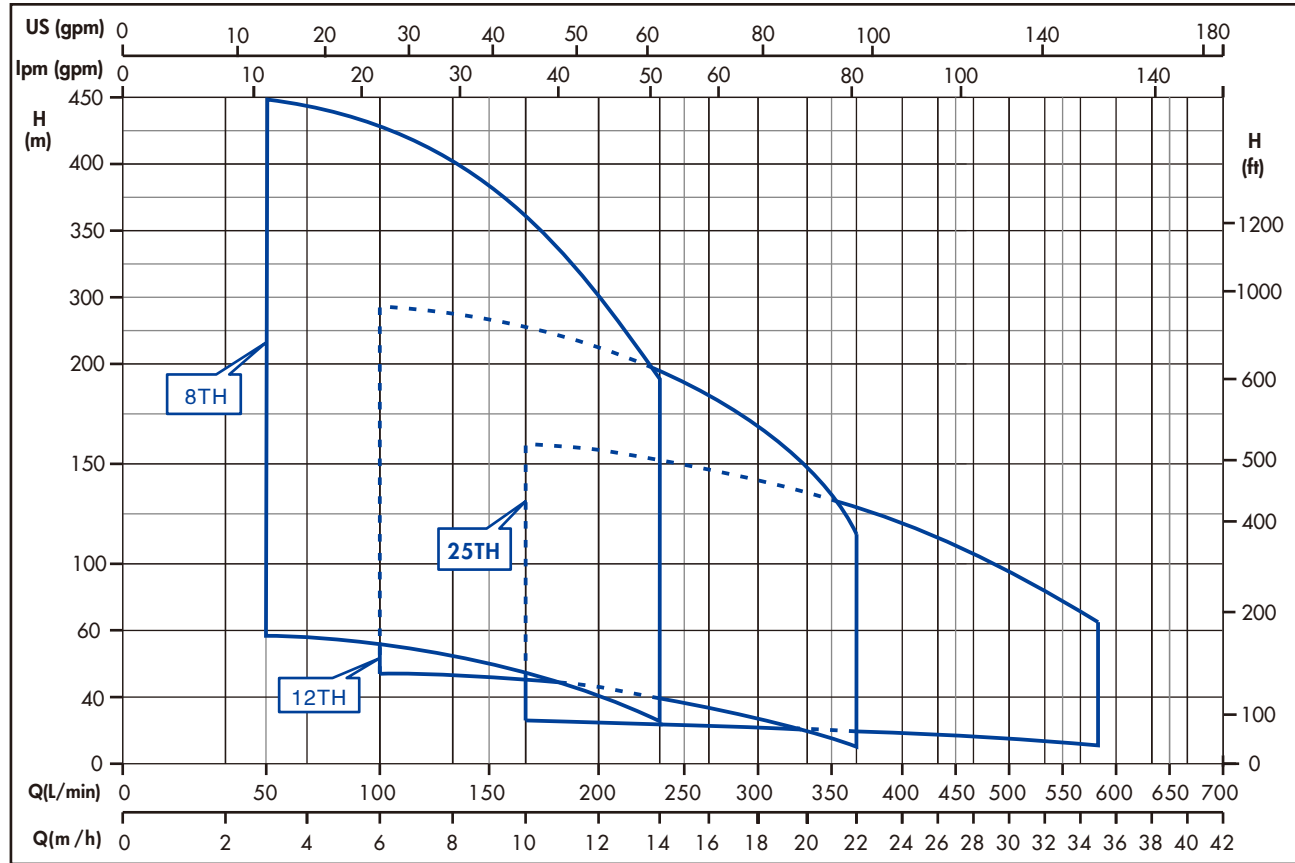

IDENTIFICATION CODE

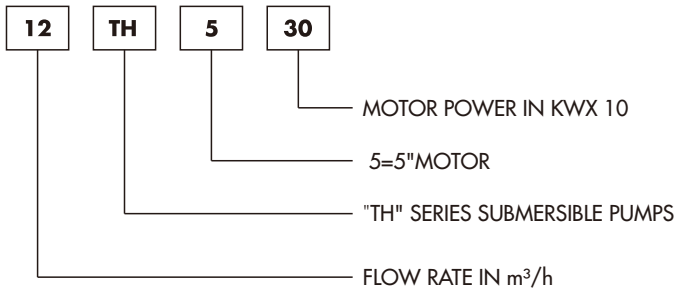

EXAMPLE OF PUMP TYPE

12TH530

TH series submersible pump with flow rate in 12 m³/h and 5" motor 3 kW (4 Hp)

TH SERIES

PUMP SECTION AND LIST OF MAIN COMPONENTS MATERIAL

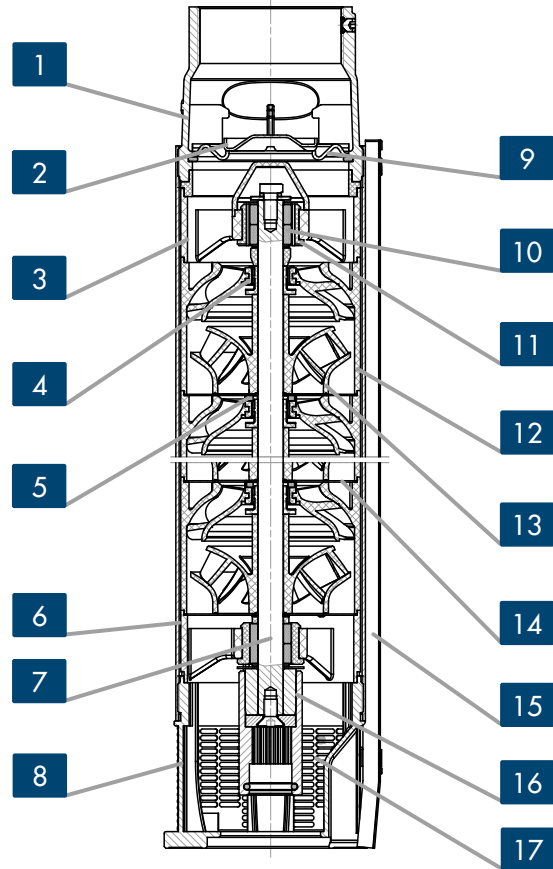
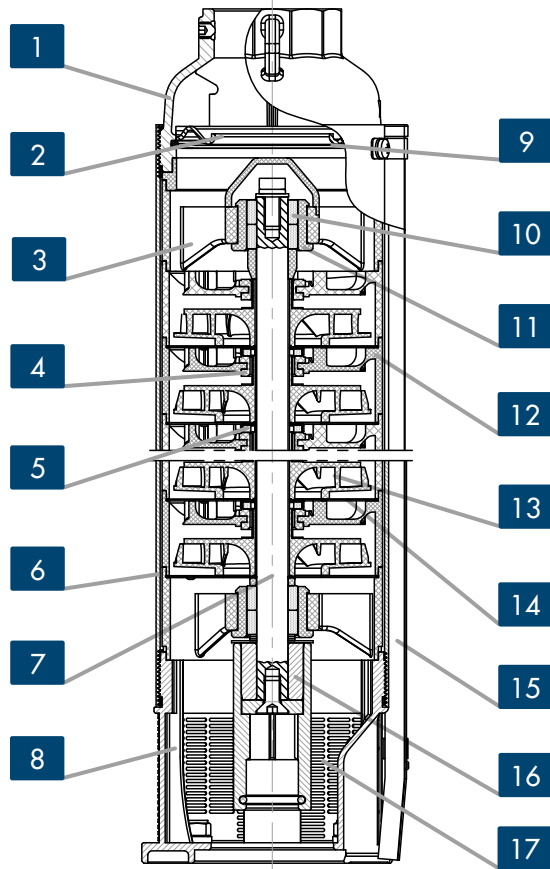

REF.N.	PART	MATERIAL	STANDARD
1	Delivery port	Precision-cast stainless steel / cast iron	AISI 304 / ASTM200A
2	Non-return valve	Stainless steel	AISI201
3	Upper support	Noryl® PPO	-----
4	Interstage bearing	NBR	-----
5	Thrust bearing	-----	-----
6	Outer sleeve	Stainless steel	AISI201
7	Shaft	Stainless steel	AISI420
8	Lower support	Precision-cast stainless steel / cast iron	AISI 304 / ASTM200A
9	Valve support	Stainless steel	AISI201
10	Shaft sleeve	Ceramic	-----
11	Bush bearing	TPU	-----
12	Diffuser	Noryl® PPO	-----
13	Impeller	Noryl POM	-----
14	Stage housing	Stainless steel	AISI201
15	Cable guard	Stainless steel	AISI201
16	Coupling	Stainless steel	AISI420
17	Filter	Stainless steel	AISI201

8TH SERIES

OPERATING CHARACTERISTICS AT 50 Hz

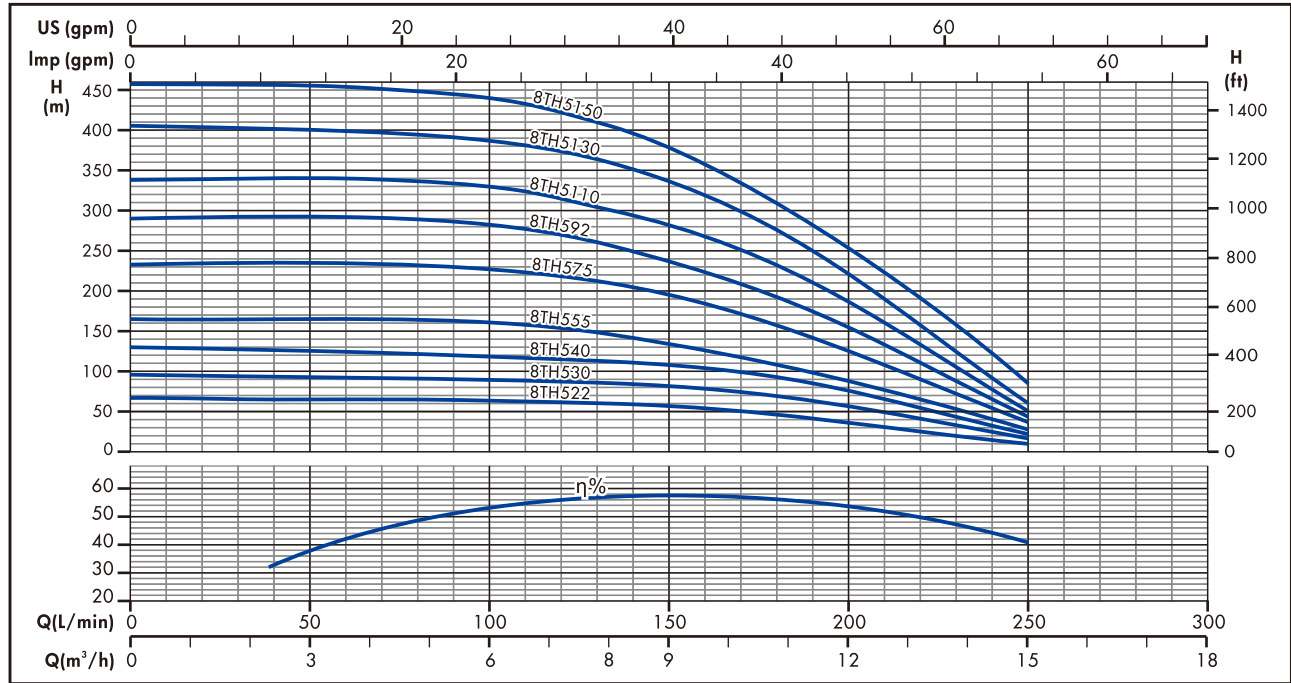

OPERATING CHARACTERISTICS AT 50 Hz

PUMP TYPE	No.OF STAGES	kW	Hp	Q=DELIVERY					
				L/min 0	67	100	133	167	233
				m³/h 0	4	6	8	10	14
H=TOTAL HEAD METERS COLUMN OF WATER									
8TH522	7	2,2	3	68	67	65	60	54	28
8TH530	10	3	4	97	96	93	86	77	40
8TH540	13	4	5,5	126	126	121	112	100	52
8TH555	17	5,5	7,5	165	164	158	148	128	67
8TH575	24	7,5	10	233	233	223	210	186	97
8TH592	30	9,2	12,5	292	290	279	258	233	121
8TH5110	35	11	15	340	339	326	300	271	142
8TH5130	42	13	17,5	409	406	391	360	326	170
8TH5150	47	15	20	454	452	435	404	366	190

DIMENSIONS AND WEIGHTS AT 50 Hz

PUMP TUPE	No.OF STAGES	DN	L mm	PUMP WEIGHT kg
8TH522	7	GAS 2"	533	10
8TH530	10		646	11
8TH540	13		759	12
8TH555	17		910	13
8TH575	24		1173	15
8TH592	30		1455	19
8TH5110	35		1663	21
8TH5130	42		1889	23
8TH5150	47		2153	25

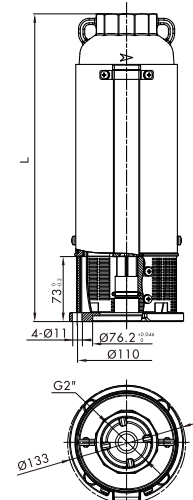

12TH SERIES

OPERATING CHARACTERISTICS AT 50 Hz

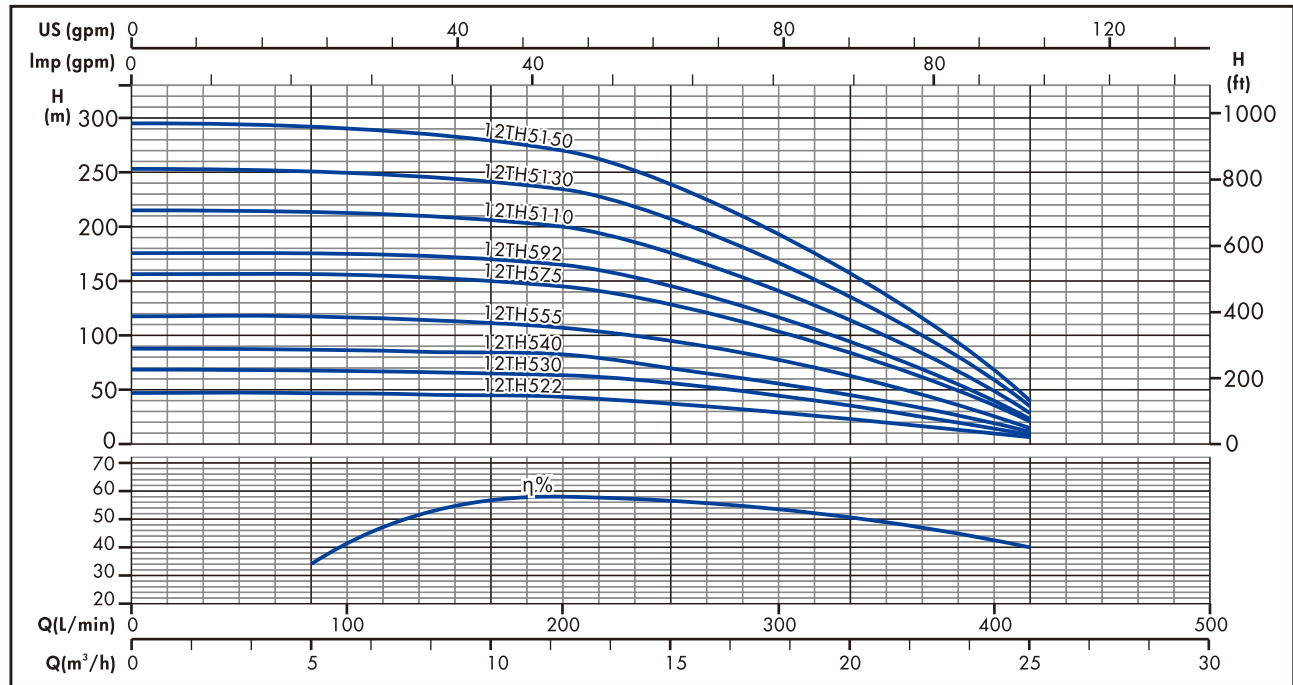

OPERATING CHARACTERISTICS AT 50 Hz

PUMP TYPE	No.OF STAGES	kW	Hp	Q=DELIVERY					
				L/min 0	67	133	200	267	367
				m ³ /h 0					
				4					
				12					
				16					
				22					
				H=TOTAL HEAD METERS COLUMN OF WATER					
12TH522	5	2,2	3	48	48	47	45	37	18
12TH530	7	3	4	68	68	66	63	52	26
12TH540	9	4	5,5	87	87	85	81	66	33
12TH555	12	5,5	7,5	117	117	113	108	89	45
12TH575	16	7,5	10	156	154	151	146	119	60
12TH592	18	9,2	12,5	175	175	171	164	133	67
12TH5110	22	11	15	216	215	208	200	162	81
12TH5130	26	13	17,5	254	253	246	234	193	97
12TH5150	30	15	20	293	292	284	270	225	114

DIMENSIONS AND WEIGHTS AT 50 Hz

PUMP TUPE	No.OF STAGES	DN	L mm	PUMP WEIGHT kg
12TH522	5	GAS 2"	465	9
12TH530	7		543	9,5
12TH540	9		622	10
12TH555	12		739	11
12TH575	16		896	12
12TH592	18		974	13
12TH5110	22		1131	18
12TH5130	26		1357	19
12TH5150	30		1516	20

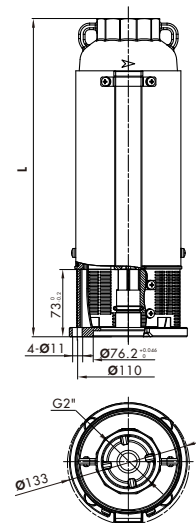

25TH SERIES

OPERATING CHARACTERISTICS AT 50 Hz

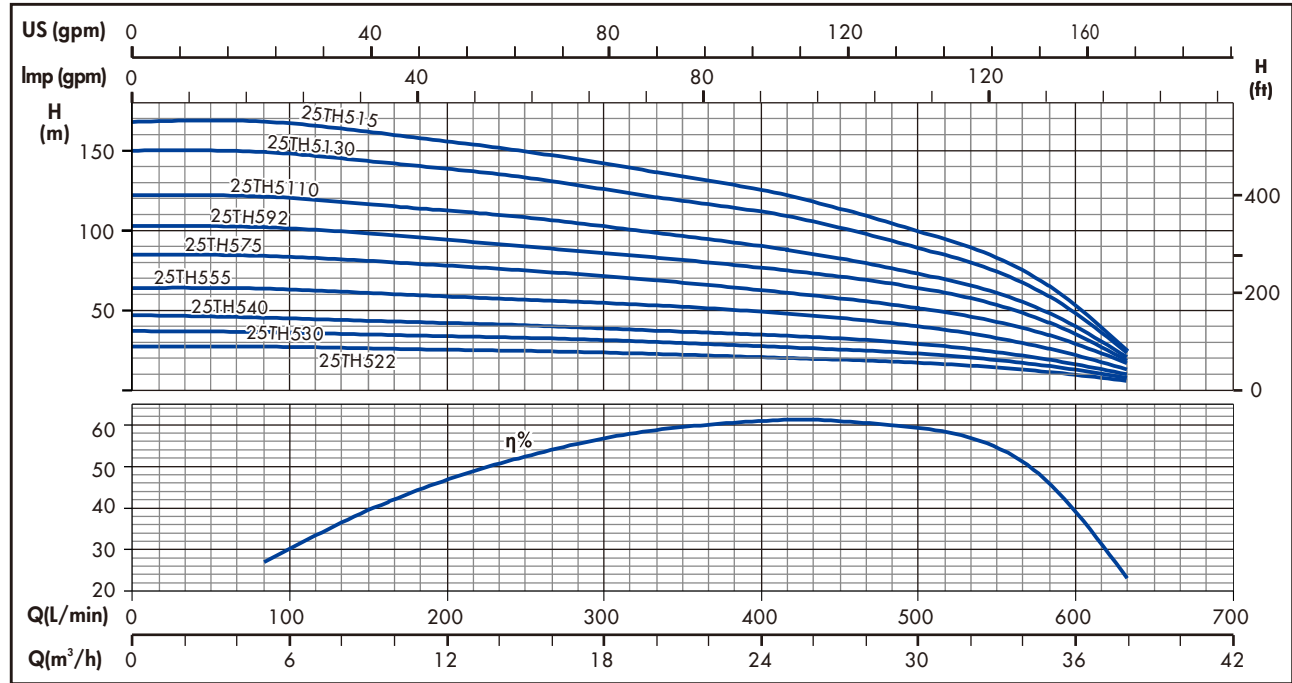

OPERATING CHARACTERISTICS AT 50 Hz

PUMP TYPE	No. OF STAGES	kW	Hp	Q=DELIVERY										
				L/min 0	83	167	250	333	417	500	583	633		
				m³/h 0										
				5	10	15	20	25	30	35	38			
H=TOTAL HEAD METERS COLUMN OF WATER														
25TH522	3	2,2	3	27	27	26	25	23	20	17	11	6		
25TH530	4	3	4	37	36	34	33	30	27	23	15	8		
25TH540	5	4	5,5	47	45	43	41	37	34	29	19	10		
25TH555	7	5,5	7,5	64	64	60	57	53	48	40	26	13		
25TH575	9	7,5	10	85	84	80	75	69	61	51	34	17		
25TH592	11	9,2	12,5	103	102	97	90	83	75	64	42	19		
25TH5110	13	11	15	122	121	115	108	99	88	73	48	21		
25TH5130	16	13	17,5	150	149	142	133	121	109	89	59	23		
25TH5150	18	15	20	168	168	160	150	137	122	100	65	25		

DIMENSIONS AND WEIGHTS AT 50 Hz

PUMP TUPE	No. OF STAGES	DN	L mm	PUMP WEIGHT kg
25TH522	3	GAS 3"	534	7
25TH530	4		614	8
25TH540	5		694,5	9
25TH555	7		854,5	10,5
25TH575	9		1015	12,5
25TH592	11		1175	14
25TH5110	13		1335,5	16
25TH5130	16		1576	19
25TH5150	18		1736,5	20,5

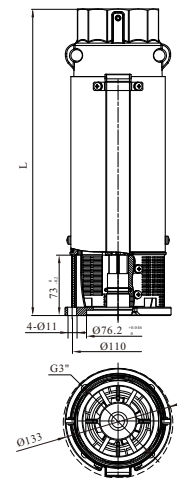

BF SERIES 6" SUBMERSIBLE PUMPS

APPLICATIONS

- Water supply from deep well.
- Agricultural irrigation.
- Pressure boosting.
- Fire-fighting.
- Industrial application.

SPECIFICATIONS

- Delivery: up to 60 m³/h at 2850 rpm.
- Head: up to 385 m at 2850 rpm.
- Maximum pump overall diameter (cable cover included): 147 mm.
- Maximum permissible quantity of sand: 150 g/m³.
- Delivery port GAS 3".
- Maximum temperature of water in contact with motor: 35 °C.

CONSTRUCTION & CHARACTERISTICS

- Sturdy and lightweight, easy to disassemble and resistant to corrosion in non-aggressive environments.
- The delivery port and lower support are made of precision-cast stainless steel, ensuring resistance to corrosion, durability and a sturdy coupling to the motor.
- The hexagonal pump shaft guarantees an effective impeller driving.
- A stainless steel non-return valve is fitted in the discharge to prevent back flow of water and alleviate water hammer to the pump, safeguarding impellers and diffusers.
- The guide bearings made of special TPU, ensure high resistance to wear and guarantee the constant and long-lasting using.
- Coupling and flange mounting dimensions meet NEMA standards.
- The BF series pumps can be coupled to the 4" or 6" motors.
- Simple maintenance, rapid installation and dismantling.
- Standard and special versions available .

OPTIONAL FEATURES

- Different voltage and frequency.
- Dual cable outlet for star/delta starting.
- Cast iron lower support and delivery port (3,0 kW to 18,5 kW)



BF SERIES

HYDRAULIC PERFORMANCE RANGE AT 50 Hz

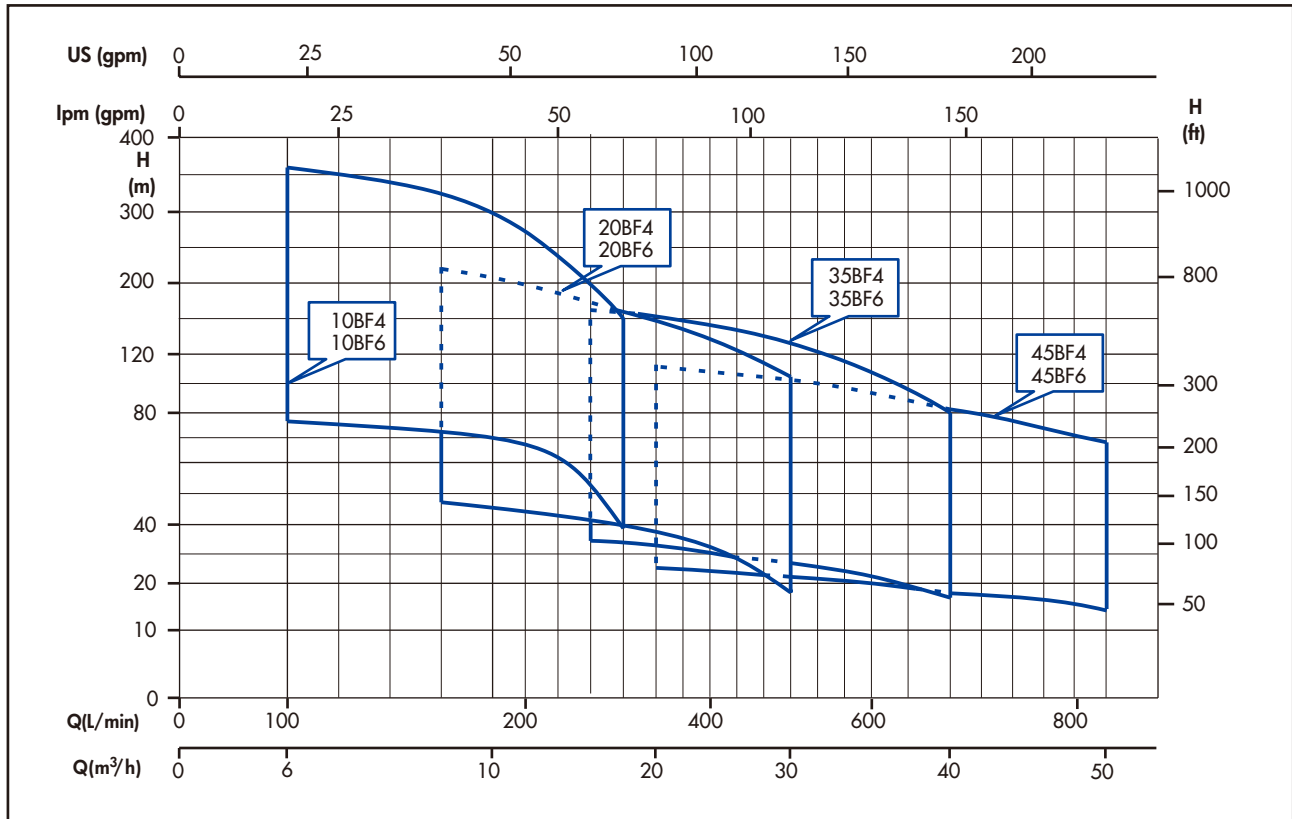

IDENTIFICATION CODE

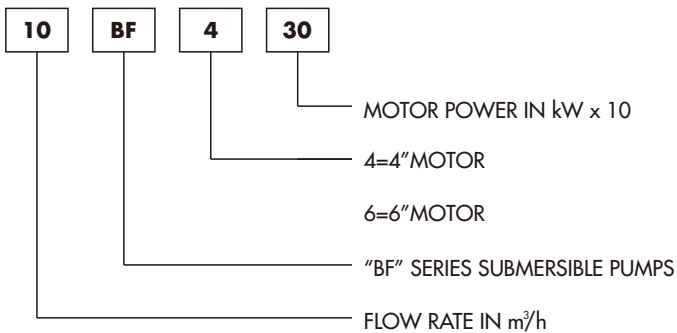

EXAMPLE OF PUMP TYPE

10BF430
 BF series submersible pump with flow rate in 10 m³/h and 4" motor 3 kW (4 Hp).

10BF-20BF SERIES

PUMP SECTION AND LIST OF MAIN COMPONENTS MATERIAL

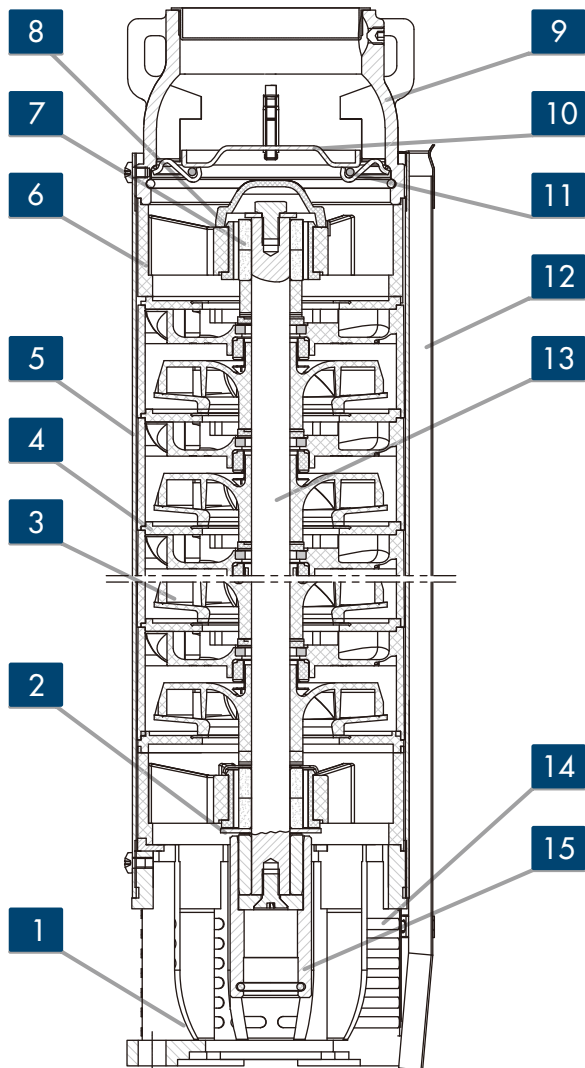

10BF6-20BF6 SERIES

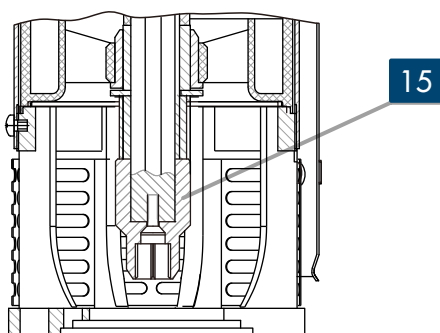

10BF4-20BF4 SERIES

REF.N.	PART	MATERIAL	STANDARD
1	Lower support	Precision-cast Stainless steel	AISI 304
2	Thrust bearing	Stainless steel	AISI 304
3	Diffuser	PC	-----
4	Impeller	POM	-----
5	Plate	PC	-----
6	Pump sleeve	Stainless steel	AISI 304
7	Upper support	PPO	-----
8	Shaft sleeve	Ceramic	-----
9	Bush bearing	TPU	TPU
10	Delivery port	Precision cast Stainless steel	AISI 304
11	Non-return valve	Stainless steel	AISI 304
12	Valve support with O-ring	Stainless steel	AISI 304
13	Cable guard	Stainless steel	AISI 304
14	Shaft	Stainless steel	AISI 420
15	Filter	Stainless steel	AISI 304
16	Coupling	Stainless steel	AISI 304

35BF-45BF SERIES

PUMP SECTION AND LIST OF MAIN COMPONENTS MATERIAL

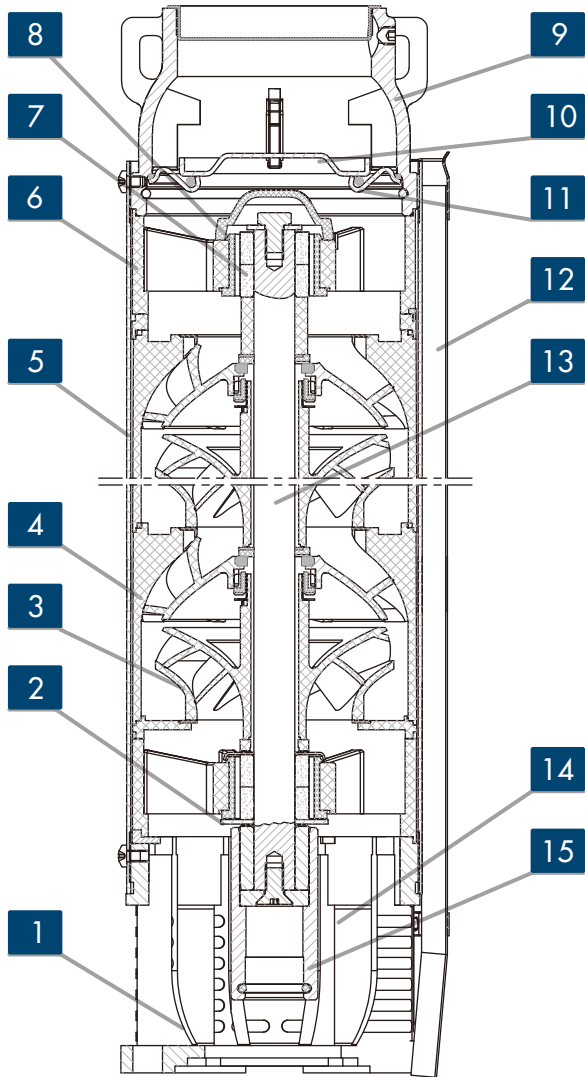

35BF6-45BF6 SERIES

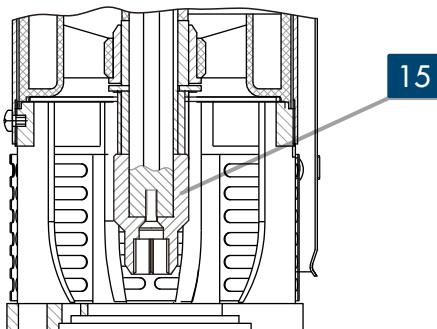

10BF4-20BF4 SERIES

REF.N.	PART	MATERIAL	STANDARD
1	Lower support	Precision-cast Stainless steel	AISI 304
2	Thrust bearing	Stainless steel	AISI 304
3	Diffuser	PC	-----
4	Impeller	POM	-----
5	Plate	PC	-----
6	Pump sleeve	Stainless steel	AISI 304
7	Upper support	PPO	-----
8	Shaft sleeve	Ceramic	-----
9	Bush bearing	TPU	TPU
10	Delivery port	Precision cast Stainless steel	AISI 304
11	Non-return valve	Stainless steel	AISI 304
12	Valve support with O-ring	Stainless steel	AISI 304
13	Cable guard	Stainless steel	AISI 304
14	Shaft	Stainless steel	AISI 420
15	Filter	Stainless steel	AISI 304
16	Coupling	Stainless steel	AISI 304

10BF SERIES OPERATING CHARACTERISTICS AT 50 Hz

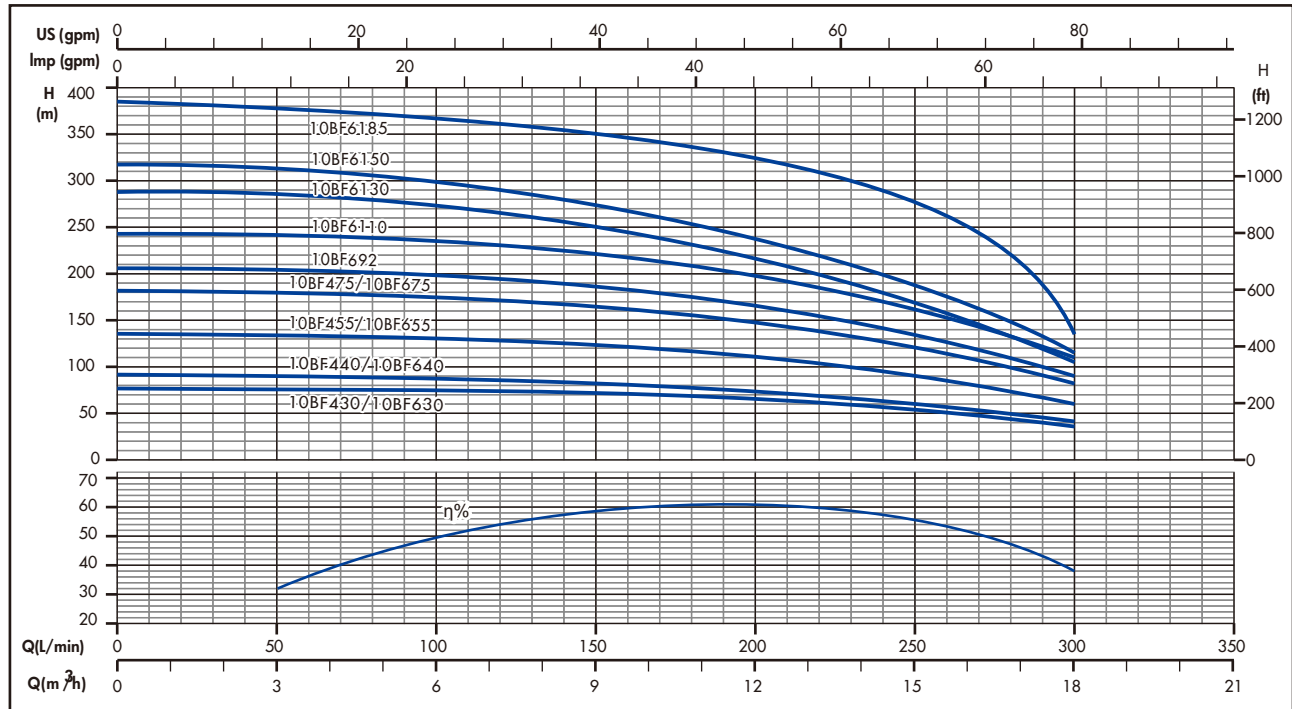

OPERATING CHARACTERISTICS AT 50 Hz

PUMP TYPE	No.OF STAGES	kW	Hp	Q=DELIVERY					
				l/min 0	100	150	200	250	300
				H=TOTAL HEAD METERS COLUMN OF WATER					
				m/h 0	6	9	12	15	18
10BF430	5	3	4	78	77	72	64	54	36
10BF630									
10BF440	6	4	5,5	91	89	87	74	60	41
10BF640									
10BF455	8	5,5	7,5	136	130	120	111	91	61
10BF655									
10BF475	11	7,5	10	182	173	165	149	121	81
10BF675									
10BF692	13	9,2	12,5	206	202	187	166	132	90
10BF6110	15	11	15	243	238	221	198	161	109
10BF6130	18	13	17,5	288	283	262	235	192	129
10BF6150	20	15	20	316	313	290	264	213	144
10BF6185	24	18,5	25	385	380	350	325	280	186

DIMENSIONS AND WEIGHTS AT 50 Hz

PUMP TYPE	No.OF STAGES	DN	L mm	PUMP WEIGHT kg
10BF430	5	GAS 3"	488,5	9
10BF630				9
10BF440	6		529,5	10
10BF640				10
10BF455	8		610,5	11
10BF655				11
10BF475	11		732,5	13
10BF675				13
10BF692	13		813,5	14
10BF6110	15		894,5	15,5
10BF6130	18	1016,5	17	
10BF6150	20	1097,5	18	
10BF6185	24	1257,5	20	

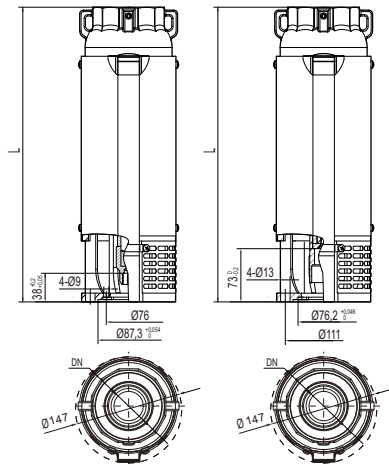

10BF4 SERIES

10BF6 SERIES

20BF SERIES

OPERATING CHARACTERISTICS AT 50 Hz

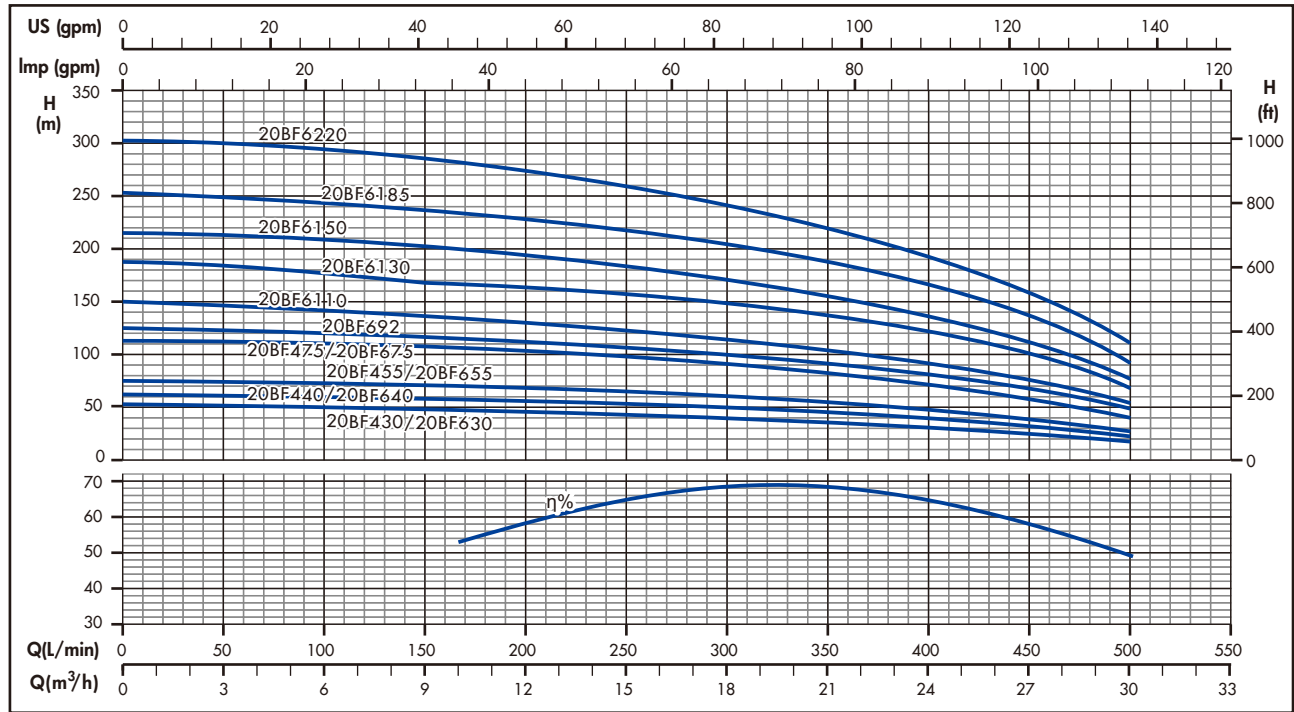

OPERATING CHARACTERISTICS AT 50 Hz

PUMP TYPE	No.OF STAGES	kW	Hp	Q=DELIVERY					
				l/min 0	150	250	350	400	500
				m ³ /h 0	9	15	21	24	30
H=TOTAL HEAD METERS COLUMN OF WATER									
20BF430	4	3	4	50	45	41	37	31	18
20BF630									
20BF440	5	4	5,5	62,5	56	51	46	39	23
20BF640									
20BF455	6	5,5	7,5	75	68	62	55	46	27
20BF655									
20BF475	9	7,5	10	112,5	101	92	83	69	40
20BF675									
20BF692	10	9,2	12,5	125	115	106	91	78	48
20BF6110	12	11	15	150	138	127	110	94	54
20BF6130	15	13	17,5	188	172	159	138	117	68
20BF6150	17	15	20	213	195	180	156	133	77
20BF6185	20	18,5	25	252	235	215	190	158	93
20BF6220	24	22	30	303	283	260	230	190	111

DIMENSIONS AND WEIGHTS AT 50 Hz

PUMP TYPE	No.OF STAGES	DN	L mm	PUMP WEIGHT kg
20BF430	4	GAS 3"	495,5	9,5
20BF630				9,5
20BF440	5		547,5	10,5
20BF640				10,5
20BF455	6		600,5	11
20BF655				11
20BF475	9		757,5	13
20BF675				13
20BF692	10		810,5	14
20BF6110	12		915,5	15
20BF6130	15	1072,5	17,5	
20BF6150	17	1177,5	19	
20BF6185	20	1335,5	22	
20BF6220	24	1545,5	25	

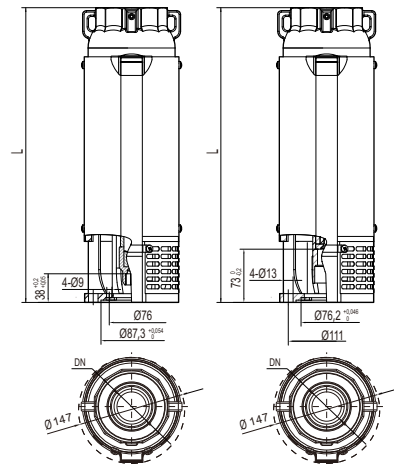

20BF4 SERIES

20BF6 SERIES

35BF SERIES

OPERATING CHARACTERISTICS AT 50 Hz

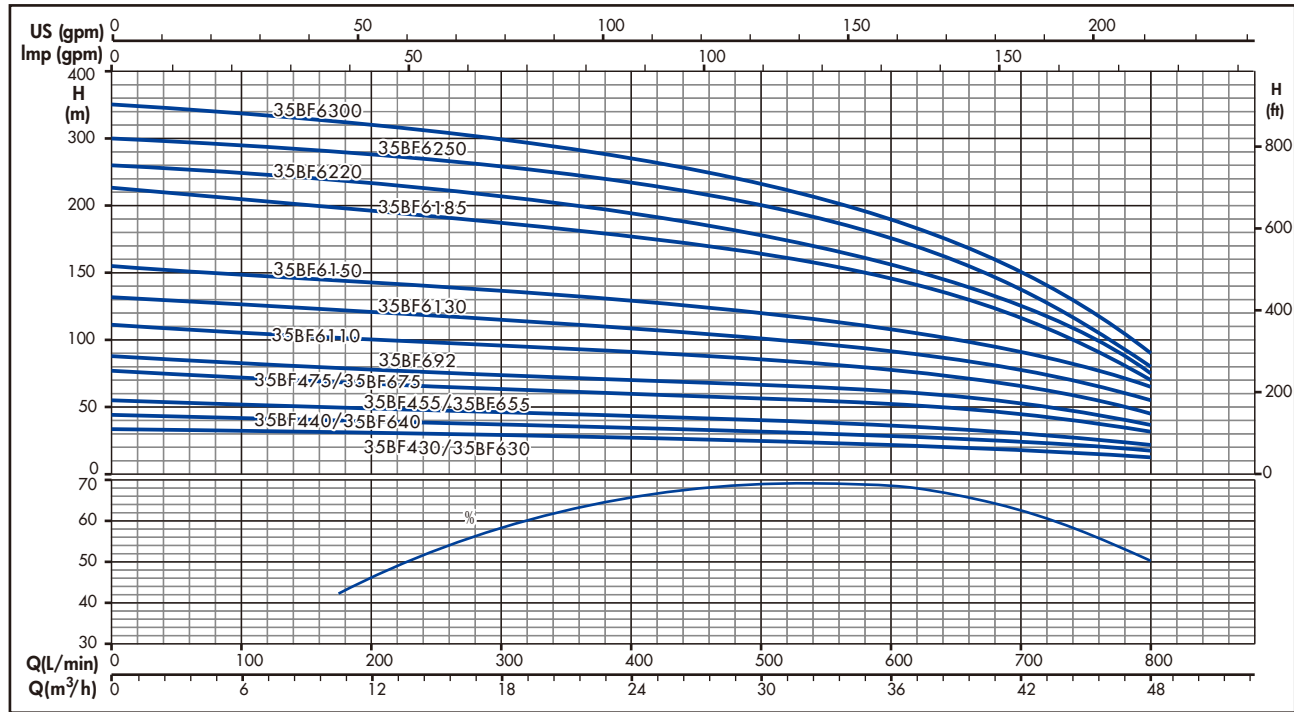

OPERATING CHARACTERISTICS AT 50 Hz

PUMP TYPE	No.OF STAGES	kW	Hp	Q=DELIVERY					
				l/min 0	300	500	600	700	800
				m ³ /h 0					
				H=TOTAL HEAD METERS COLUMN OF WATER					
35BF430	3	3	4	33	28	26	21	19	13
35BF630	3	3	4	33	28	26	21	19	13
35BF440	4	4	5,5	44	37	34	28	25	18
35BF640	4	4	5,5	44	37	34	28	25	18
35BF455	5	5,5	7,5	55	46	43	36	32	23
35BF655	5	5,5	7,5	55	46	43	36	32	23
35BF475	7	7,5	10	77	65	60	53	45	32
35BF675	7	7,5	10	77	65	60	53	45	32
35BF692	8	9,2	12,5	88	75	69	62	51	36
35BF6110	10	11	15	110	92	86	78	64	45
35BF6130	12	13	17,5	132	111	103	93	77	54
35BF6150	14	15	20	154	130	121	107	89	64
35BF6185	17	18,5	25	222	185	154	123	101	70
35BF6220	20	22	30	260	218	182	150	106	75
35BF6250	23	25	34	300	251	209	175	112	79
35BF6300	27	30	40	352	295	246	205	118	83

DIMENSIONS AND WEIGHTS AT 50 Hz

PUMP TYPE	No.OF STAGES	DN	L mm	PUMP WEIGHT kg
35BF430	3	GAS 3"	545,5	9
35BF630	3			9
35BF440	4		630,5	10
35BF640	4			10
35BF455	5		714,5	11,5
35BF655	5			11,5
35BF475	7		882,5	13
35BF675	7			13
35BF692	8		967,5	14
35BF6110	10		1135,5	16
35BF6130	12		1304,5	18
35BF6150	14		1472,5	20
35BF6185	17		1725,5	23
35BF6220	20		1978,5	26
35BF6250	23	2231,5	29	
35BF6300	27	2568,5	33	

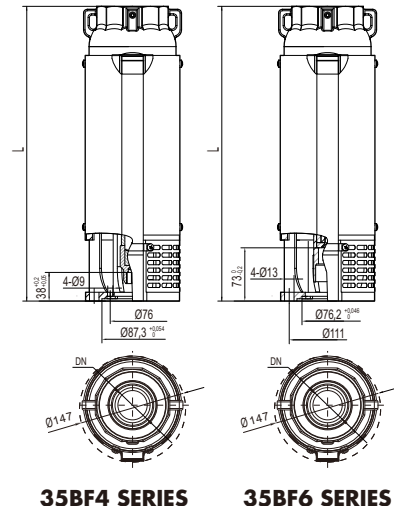

35BF4 SERIES

35BF6 SERIES

45BF SERIES

OPERATING CHARACTERISTICS AT 50 Hz

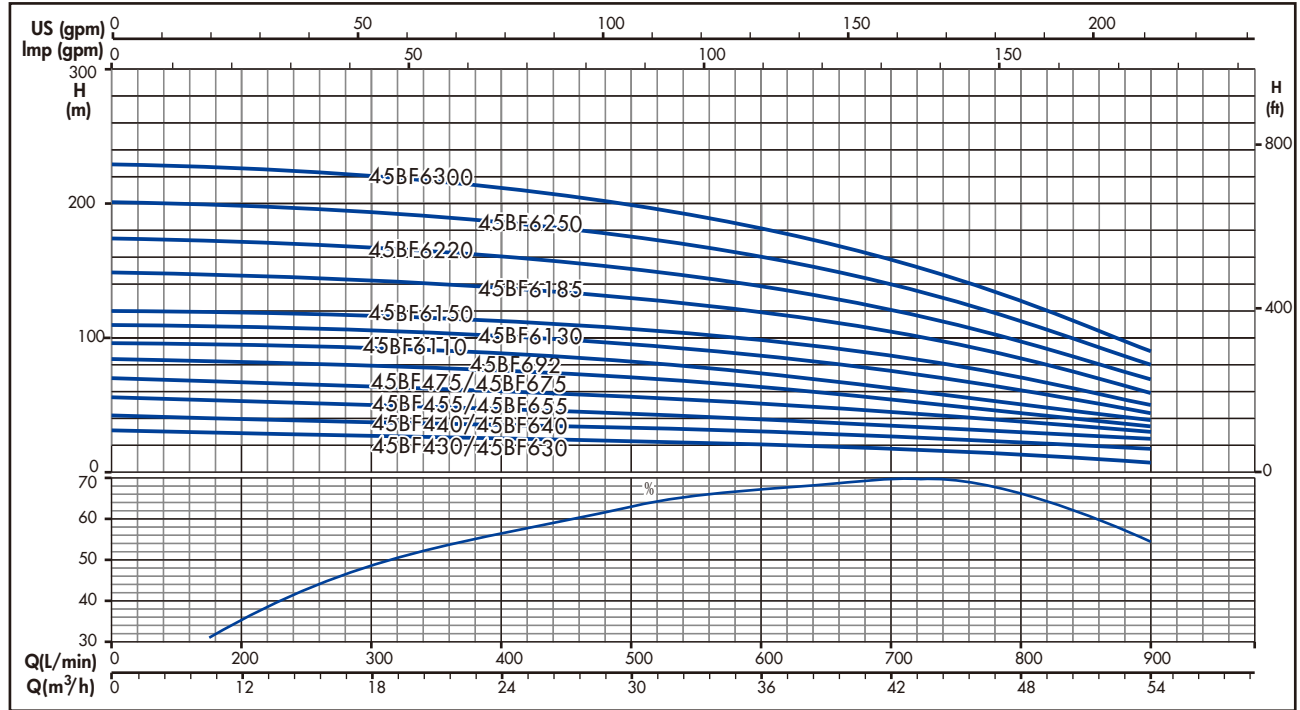

OPERATING CHARACTERISTICS AT 50 Hz

PUMP TYPE	No.OF STAGES	kW	Hp	Q=DELIVERY					
				l/min 0	300	500	700	800	900
				m ³ /h 0	18	30	42	48	54
H=TOTAL HEAD METERS COLUMN OF WATER									
45BF430	2	3	4	28	24	21	18	14	12
45BF630									
45BF440	3	4	5,5	41	36	31	27	23	18
45BF640									
45BF455	4	5,5	7,5	56	49	42	35	30	23
45BF655									
45BF475	5	7,5	10	70	61	52	44	38	30
45BF675									
45BF692	6	9,2	12,5	80	72	63	52	44	33
45BF6110	7	11	15	94	84	73	61	51	39
45BF6130	8	13	17,5	107	96	84	70	59	45
45BF6150	9	15	20	120	108	94	78	66	50
45BF6185	11	18,5	25	147	132	115	95	80	58
45BF6220	13	22	30	174	156	136	113	94	68
45BF6250	15	15	34	201	180	157	130	109	79
45BF6300	17	30	40	227	204	178	147	124	90

DIMENSIONS AND WEIGHTS AT 50 Hz

PUMP TYPE	No.OF STAGES	DN	L mm	PUMP WEIGHT kg
45BF430	2	GAS 3"	765,5	8,5
45BF630				8,5
45BF440	3		568,5	9,5
45BF640				9,5
45BF455	4		660,5	10,5
45BF655				10,5
45BF475	5		752,5	12,5
45BF675				12,5
45BF692	6		844,5	13,5
45BF6110	7		936,5	15
45BF6130	8		1028,5	16,5
45BF6150	9		1120,5	18
45BF6185	11		1304,5	20
45BF6220	13		1488,5	22
45BF6250	15	1672,5	24	
45BF6300	17	1856,5	26	

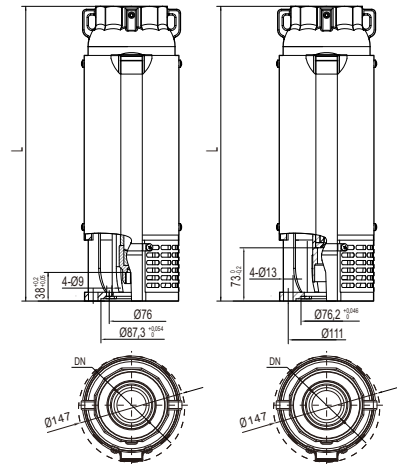

45BF4 SERIES

45BF6 SERIES

BP SERIES 6" SUBMERSIBLE PUMPS

- Completely made of corrosion-resistant stainless steel AISI 304, BP pumps are ideal for a wide variety of applications with high efficiency and reliability.

APPLICATIONS

- Water supply from deep well.
- Agricultural irrigation.
- Pressure boosting.
- Fire-fighting.
- Industrial application.

SPECIFICATIONS

- Delivery: up to 80 m³/h at 2850 rpm.
- Head: up to 715 m at 2850 rpm.
- Maximum overall diameter of pump: 156 mm (one cable guard included).
- Maximum permissible quantity of suspended sand: 150 g/m³.
- 17BP , 30BP Standard delivery port: Rp 3".
- 46BP , 60BP Standard delivery port: Rp 4".

MOTOR

- Three-phase:
from 2,2 to 45 kW, 380 V, 50 Hz.

CONSTRUCTION CHARACTERISTICS

- Sturdy and lightweight, easy to maintain and resistant to corrosion in non-aggressive environments.
- High efficient hydraulic design for cost saving and best performance.
- Stainless steel built-in non-return valve.
- Stainless steel impellers and diffusers.
- Stainless steel delivery port and suction support.
- Stainless steel shaft and replaceable coupling.
- Coupling and flange mounting dimensions meet NEMA standards.

OPTIONAL FEATURES

- Different voltage and frequency.
- Delivery port: Rp4".



BP SERIES

HYDRAULIC PERFORMANCE RANGE AT 50 Hz

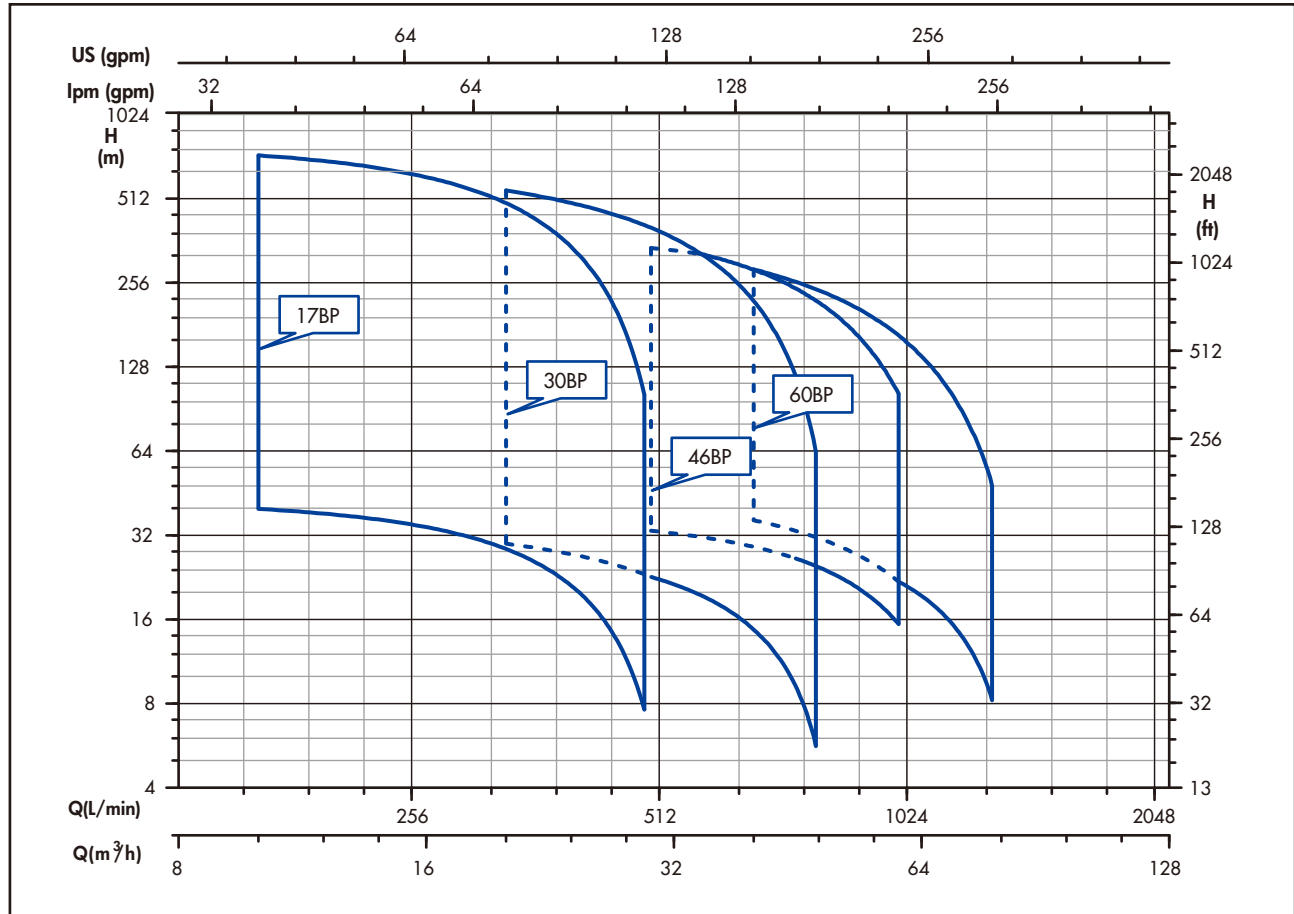

IDENTIFICATION CODE

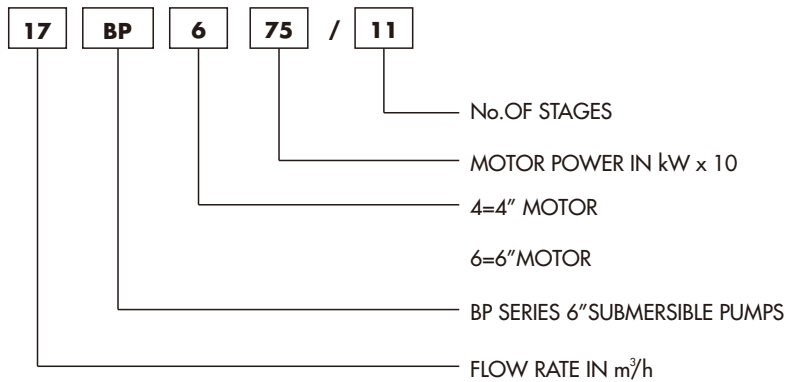

EXAMPLE OF PUMP TYPE

17BP675/11

BP series submersible pump with flow rate 17 m³/h, No. of stages 11, and 6" submersible motor 7,5 kW (10 Hp).



17BP SERIES

PUMP SECTION AND LIST OF MAIN COMPONENTS MATERIAL

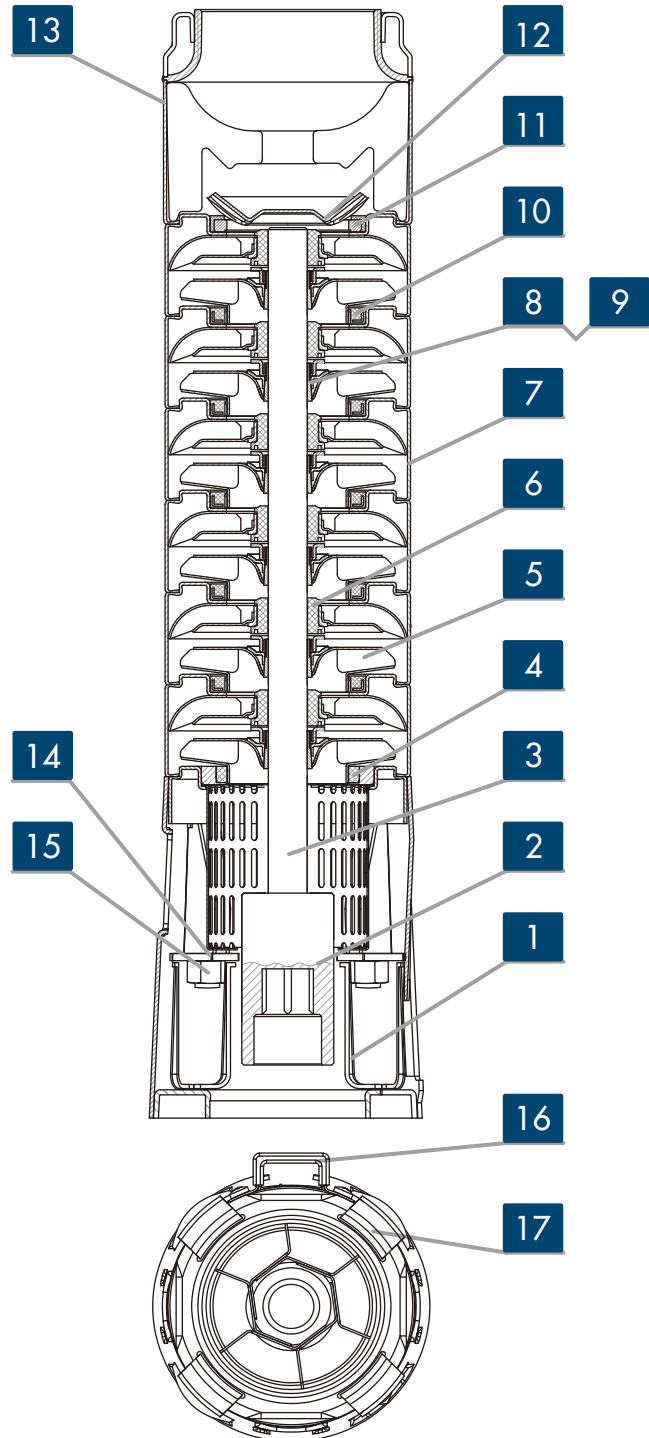

REF.N.	PART	MATERIAL	STANDARD
1	Lower support	Stainless steel	AISI 304
2	Coupling	Stainless steel	AISI 304
3	Shaft	Stainless steel	AISI 304
4	First neck ring	NBR	-----
5	Impeller	Stainless steel	AISI 304
6	Bush bearing		-----
7	Diffuser	Stainless steel	AISI 304
8	Split cone	Stainless steel	AISI 304
9	Split cone nut	Stainless steel	AISI 304
10	Neck ring	NBR	-----
11	Valve support	NBR	-----
12	Non-return valve	Stainless steel	AISI 304
13	Delivery port	Stainless steel	AISI 304
14	Washer	Stainless steel	AISI 304
15	Nut for strap	Stainless steel	AISI 304
16	Cable guard	Stainless steel	AISI 304
17	Strap	Stainless steel	AISI 304

30BP SERIES

PUMP SECTION AND LIST OF MAIN COMPONENTS MATERIAL

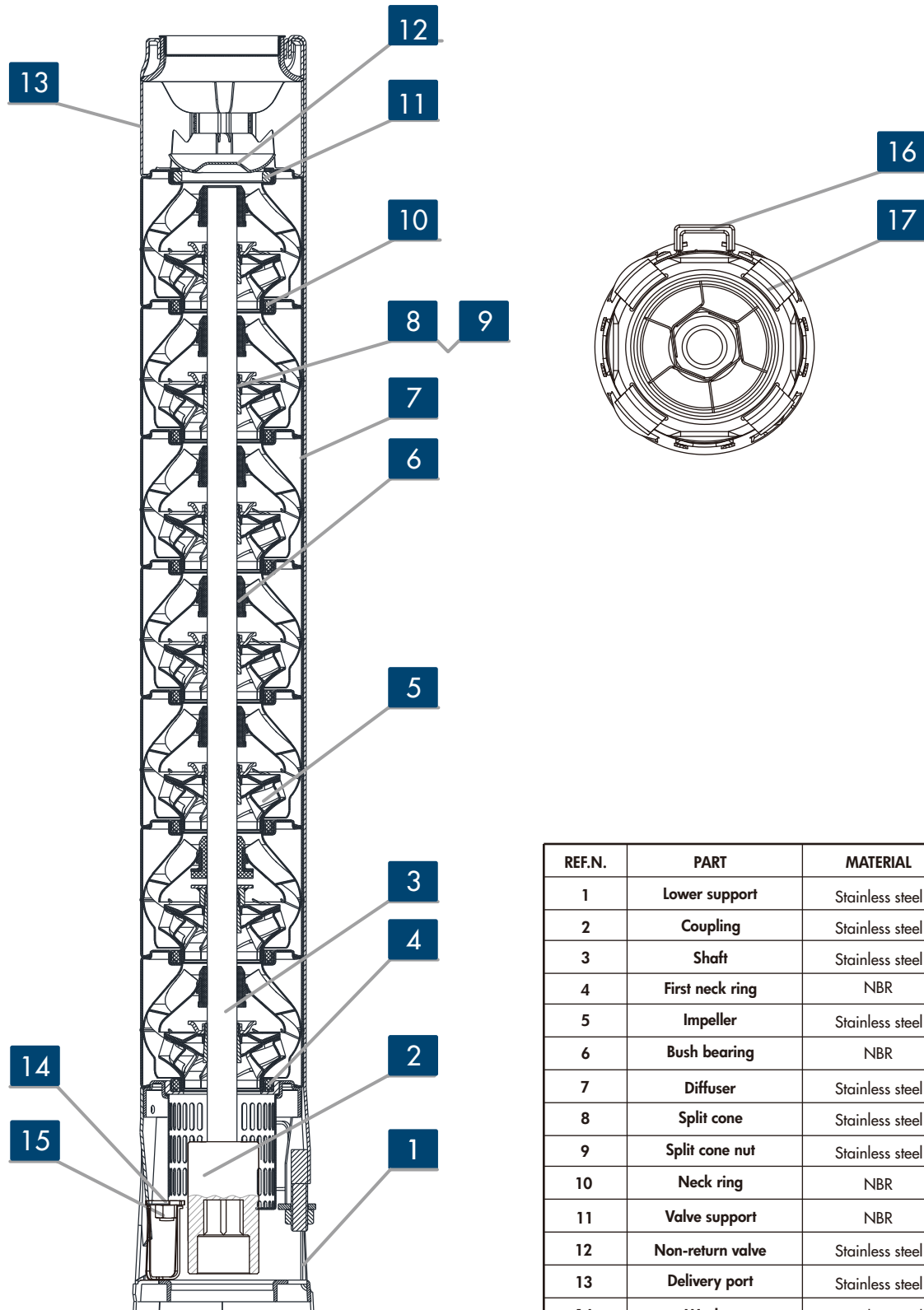

REF.N.	PART	MATERIAL	STANDARD
1	Lower support	Stainless steel	AISI 304
2	Coupling	Stainless steel	AISI 304
3	Shaft	Stainless steel	AISI 304
4	First neck ring	NBR	-----
5	Impeller	Stainless steel	AISI 304
6	Bush bearing	NBR	-----
7	Diffuser	Stainless steel	AISI 304
8	Split cone	Stainless steel	AISI 304
9	Split cone nut	Stainless steel	AISI 304
10	Neck ring	NBR	-----
11	Valve support	NBR	-----
12	Non-return valve	Stainless steel	AISI 304
13	Delivery port	Stainless steel	AISI 304
14	Washer	Stainless steel	AISI 304
15	Nut for strap	Stainless steel	AISI 304
16	Cable guard	Stainless steel	AISI 304
17	Strap	Stainless steel	AISI 304

46BP-60BP SERIES

PUMP SECTION AND LIST OF MAIN COMPONENTS MATERIAL

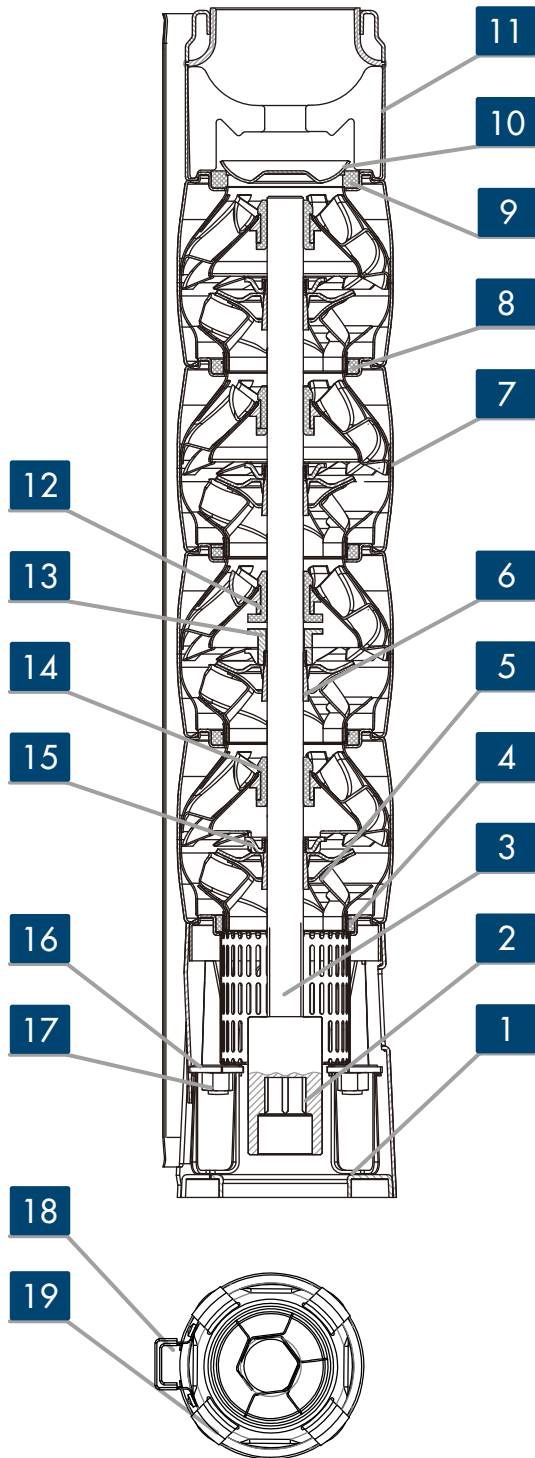

REF.N.	PART	MATERIAL	STANDARD
1	Lower support	Stainless steel	AISI 304
2	Coupling	Stainless steel	AISI 304
3	Shaft	Stainless steel	AISI 304
4	First neck ring	NBR	-----
5	Impeller	Stainless steel	AISI 304
6	Split cone	Stainless steel	AISI 304
7	Diffuser	Stainless steel	AISI 304
8	Neck ring	NBR	-----
9	Valve support	NBR	-----
10	Non-return valve	Stainless steel	AISI 304
11	Delivery port	Stainless steel	AISI 304
12	Thrust bearing	NBR	-----
13	Nut for stop ring	Stainless steel	AISI 304
14	Bush bearing	NBR	-----
15	Split cone nut	Stainless steel	AISI 304
16	Washer	Stainless steel	AISI 304
17	Nut for strap	Stainless steel	AISI 304
18	Cable guard	Stainless steel	AISI 304
19	Strap	Stainless steel	AISI 304

17BP SERIES

OPERATING CHARACTERISTICS AT 50 Hz

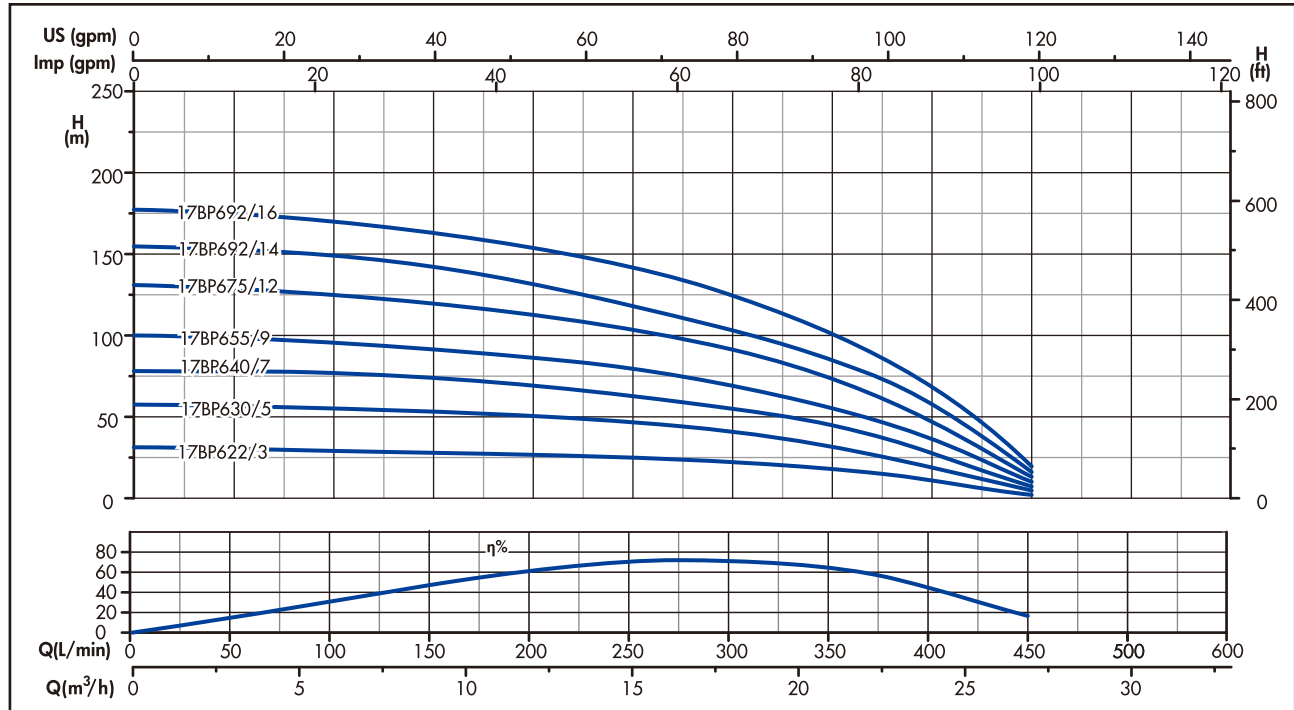

OPERATING CHARACTERISTICS AT 50 Hz

PUMP TYPE	No.OF STAGES	kW	Hp	Q=DELIVERY						
				l/min 0	167	250	283	317	367	433
				m3/h 0	10	15	17	19	22	26
H=TOTAL HEAD METERS COLUMN OF WATER										
17BP622/3	3	2,2	3	33	30	26	24	20	14	3
17BP630/5	5	3	4	55	50	44	40	34	23	6
17BP640/7	7	4	5,5	77	70	62	56	48	33	8
17BP655/9	9	5,5	7,5	99	90	79	72	61	42	10
17BP675/12	12	7,5	10	132	120	106	96	82	56	14
17BP692/14	14	9,2	12,5	154	140	123	112	95	65	16
17BP692/16	16	9,2	12,5	176	160	141	128	109	74	18

DIMENSIONS AND WEIGHTS AT 50 Hz

PUMP TYPE	No.OF STAGES	DN	L mm	PUMP WEIGHT kg
17BP622/3	3	Rp3"	451	8,2
17BP630/5	5		572	10,6
17BP640/7	7		693	13
17BP655/9	9		814	15,4
17BP675/12	12		995	19
17BP692/14	14		1116	21,4
17BP692/16	16		1237	23,8

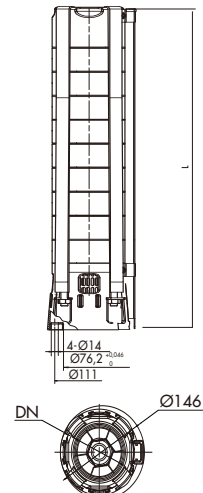

17BP SERIES

OPERATING CHARACTERISTICS AT 50 Hz

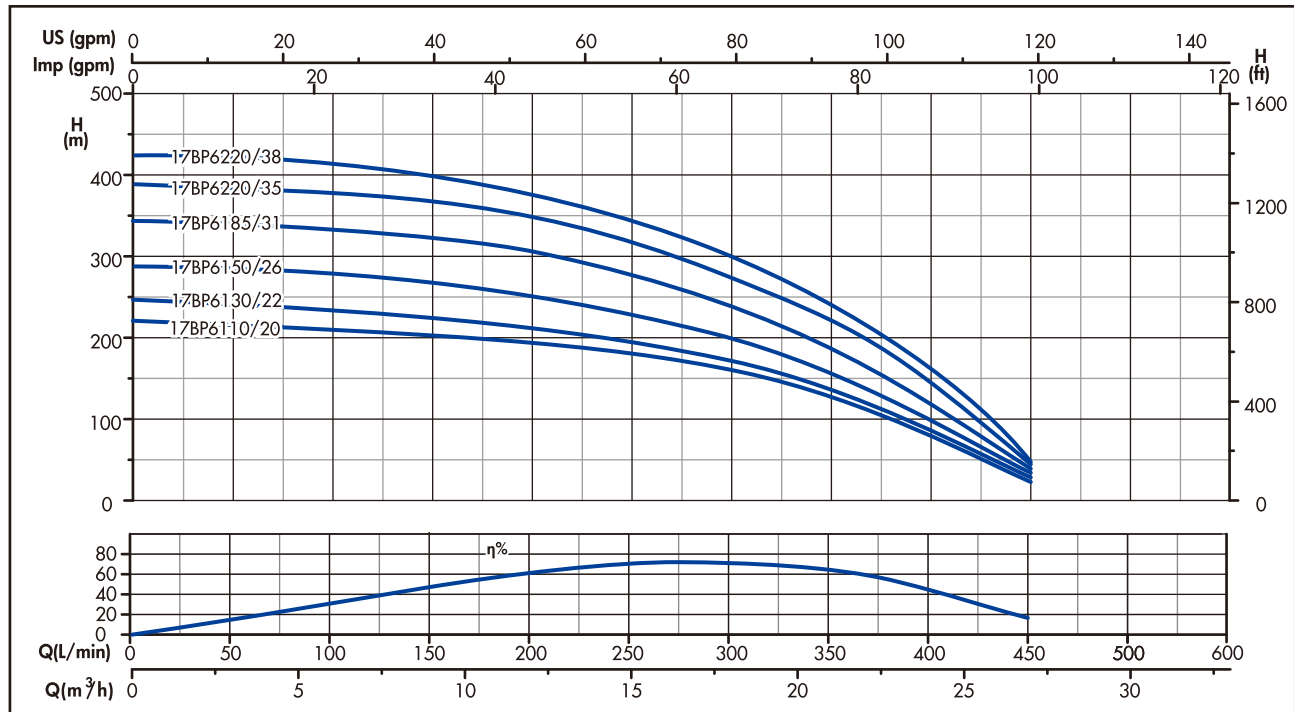

OPERATING CHARACTERISTICS AT 50 Hz

PUMP TYPE	No. OF STAGES	kW	Hp	Q=DELIVERY						
				l/min 0	167	250	283	317	367	433
				m³/h 0						
				10	15	17	19	22	26	
				H=TOTAL HEAD METERS COLUMN OF WATER						
17BP6110/20	20	11	15	220	200	176	160	136	93	23
17BP6130/22	22	13	17,5	242	220	194	176	150	102	25
17BP6150/26	26	15	20	286	260	229	208	177	121	30
17BP6185/31	31	18,5	25	341	310	273	248	211	144	36
17BP6220/35	35	22	30	385	350	308	280	238	163	40
17BP6220/38	38	22	30	418	380	334	304	258	177	44

DIMENSIONS AND WEIGHTS AT 50 Hz

PUMP TYPE	No. OF STAGES	DN	L mm	PUMP WEIGHT kg
17BP6110/20	20	Rp3"	1479	28,6
17BP6130/22	22		1600	31
17BP6150/26	26		1844	35,9
17BP6185/31	31		2147	41,9
17BP6220/35	35		2389	46,7
17BP6220/38	38		2570	50,3

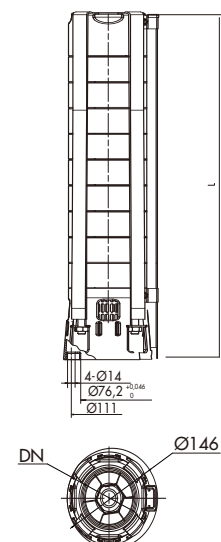

17BP SERIES

OPERATING CHARACTERISTICS AT 50 Hz

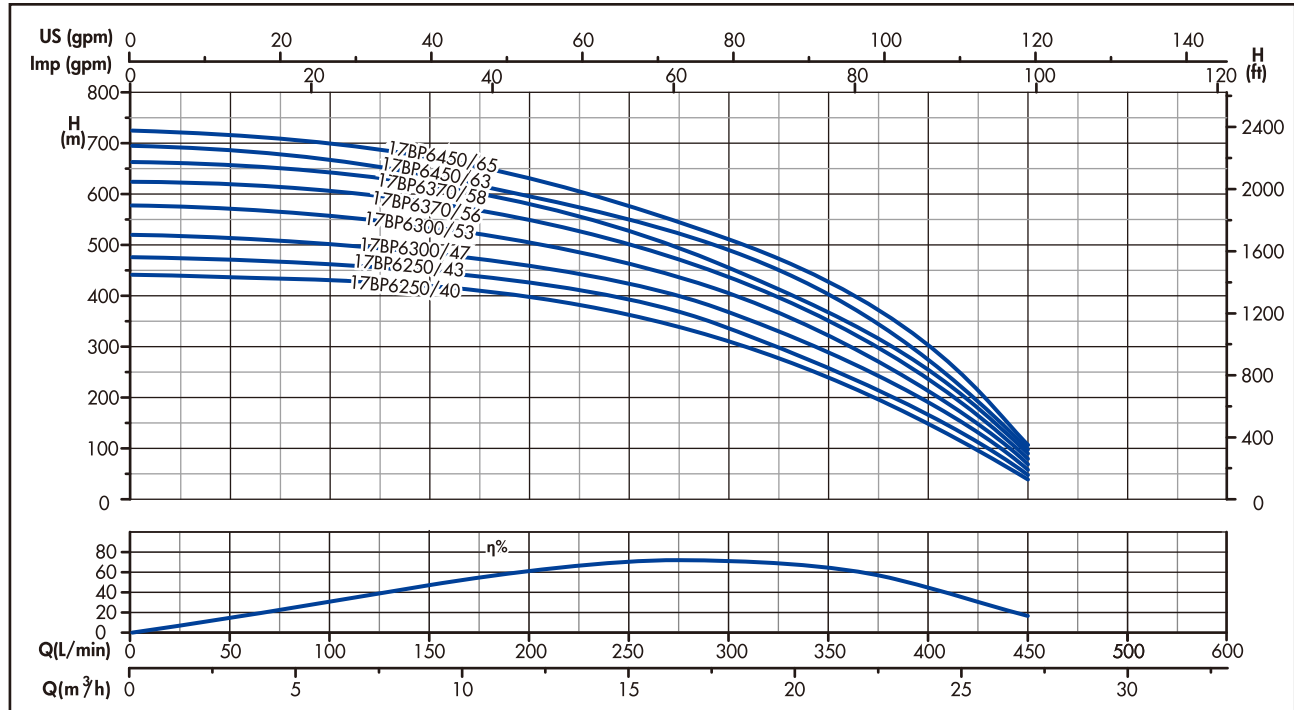

OPERATING CHARACTERISTICS AT 50 Hz

PUMP TYPE	No.OF STAGES	kW	Hp	Q=DELIVERY						
				l/min 0	167	250	283	317	367	433
				m³/h 0	10	15	17	19	22	26
H=TOTAL HEAD METERS COLUMN OF WATER										
17BP6250/40	40	25	35	440	400	352	320	272	186	46
17BP6250/43	43	25	35	473	430	378	344	292	200	49
17BP6300/47	47	30	40	517	470	414	376	320	219	54
17BP6300/53	53	30	40	583	530	466	424	360	246	61
17BP6370/56	56	37	50	616	560	493	448	381	260	64
17BP6370/58	58	37	50	638	580	510	464	394	270	67
17BP6450/63	63	45	60	693	630	554	504	428	293	72
17BP6450/65	65	45	60	715	650	572	520	442	302	75

DIMENSIONS AND WEIGHTS AT 50 Hz

PUMP TYPE	No.OF STAGES	DN	L mm	PUMP WEIGHT kg
17BP6250/40	40	Rp3"	2091	52,7
17BP6250/43	43		2873	85,9
17BP6300/47	47		3115	90,7
17BP6300/53	53		3478	97,9
17BP6370/56	56		3659	101,5
17BP6370/58	58		3780	103,9
17BP6450/63	63		4083	109,9
17BP6450/65	65		4204	112,3

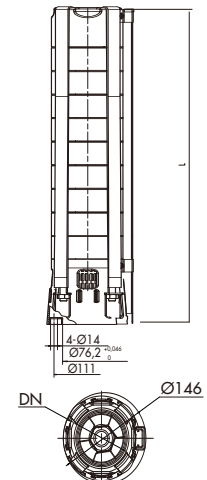

30BP SERIES

OPERATING CHARACTERISTICS AT 50 Hz

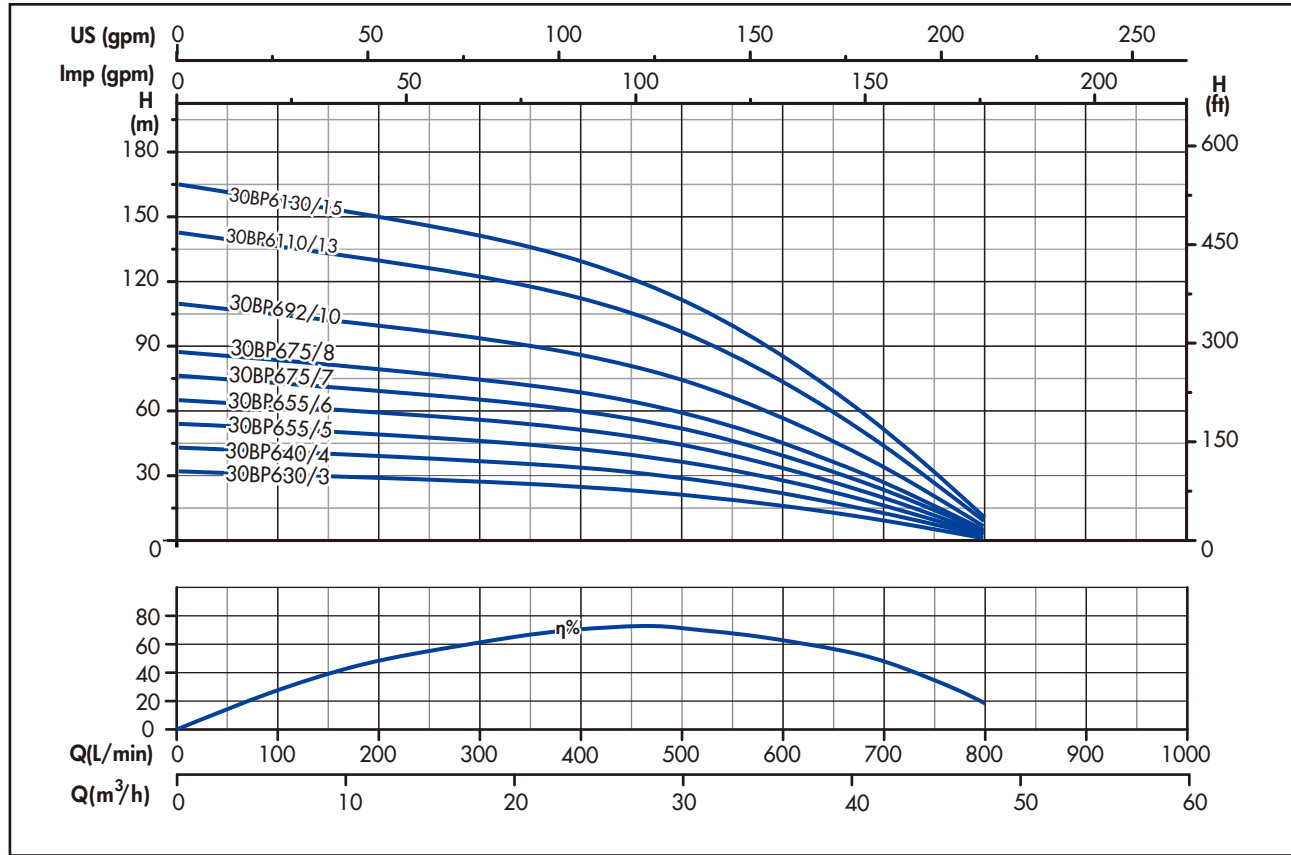

OPERATING CHARACTERISTICS AT 50 Hz

PUMP TYPE	No. OF STAGES	kW	Hp	Q=DELIVERY						
				l/min 0	300	400	500	600	700	833
				m³/h 0	18	24	30	36	42	48
H=TOTAL HEAD METERS COLUMN OF WATER										
30BP630/3	3	3	4	33	29	26	23	18	11	2
30BP640/4	4	4	5,5	44	38	35	31	23	15	3
30BP655/5	5	5,5	7,5	55	48	44	39	29	18	4
30BP655/6	6	5,5	7,5	66	57	53	46	35	22	5
30BP675/7	7	7,5	10	77	67	61	54	41	26	6
30BP675/8	8	7,5	10	88	76	70	62	47	29	7
30BP692/10	10	9,2	12,5	110	95	88	77	58	37	8
30BP6110/13	13	11	15	143	124	114	100	76	47	10
30BP6130/15	15	13	17,5	165	143	131	116	88	55	12

DIMENSIONS AND WEIGHTS AT 50 Hz

PUMP TYPE	No. OF STAGES	DN	L mm	PUMP WEIGHT kg
30BP630/3	3	Rp3" (Rp4")	557	9,9
30BP640/4	4		653	11,7
30BP655/5	5		749	13,5
30BP655/6	6		845	15,3
30BP675/7	7		941	17,1
30BP675/8	8		1037	18,9
30BP692/10	10		1229	22,5
30BP6110/13	13		1517	27,9
30BP6130/15	15		1709	31,5

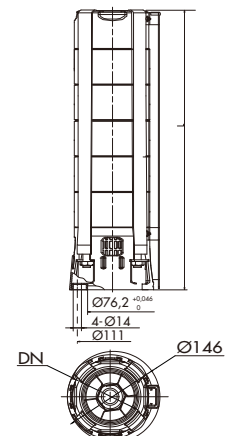

30BP SERIES

OPERATING CHARACTERISTICS AT 50 Hz

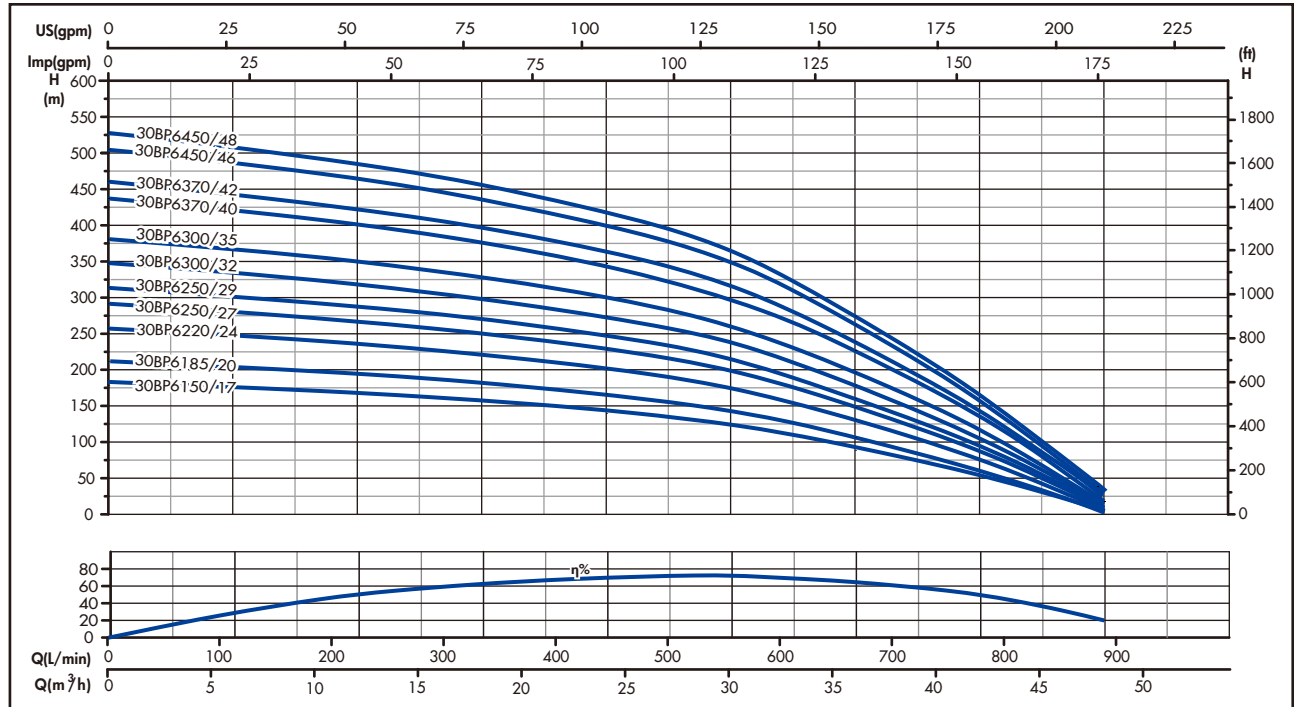

OPERATING CHARACTERISTICS AT 50 Hz

PUMP TYPE	No. OF STAGES	kW	Hp	Q=DELIVERY							
				l/min 0	300	400	500	600	700	833	
				m³/h 0 18 24 30 36 42 48							
				H=TOTAL HEAD METERS COLUMN OF WATER							
30BP6150/17	17	15	20	187	162	149	131	99	62	13	
30BP6185/20	20	18,5	25	220	191	175	154	117	73	16	
30BP6220/24	24	22	30	264	229	210	185	140	88	19	
30BP6250/27	27	25	35	296	258	237	208	158	99	21	
30BP6250/29	29	25	35	318	277	254	223	170	106	23	
30BP6300/32	32	30	40	351	305	280	246	187	117	25	
30BP6300/35	35	30	40	384	334	307	270	205	128	28	
30BP6370/40	40	37	50	439	382	351	308	234	146	31	
30BP6370/42	42	37	50	461	401	368	323	246	153	33	
30BP6450/46	46	45	60	505	439	403	354	269	168	36	
30BP6450/48	48	45	60	527	458	421	370	281	175	38	

DIMENSIONS AND WEIGHTS AT 50 Hz

PUMP TYPE	No. OF STAGES	DN	L mm	PUMP WEIGHT kg
30BP6150/17	17	Rp3" (Rp4")	1901	35,1
30BP6185/20	20		2189	40,5
30BP6220/24	24		2573	43,7
30BP6250/27	27		2863	59,3
30BP6250/29	29		3055	62,9
30BP6300/32	32		3343	68,3
30BP6300/35	35		3631	73,7
30BP6370/40	40		4111	82,7
30BP6370/42	42		4303	86,3
30BP6450/46	46		4687	93,5
30BP6450/48	48		4879	97,1

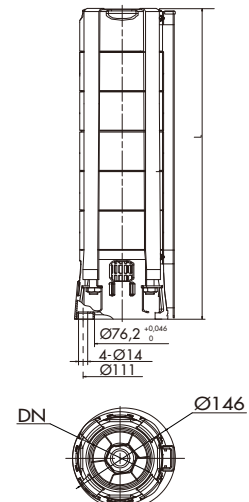

46BP SERIES

OPERATING CHARACTERISTICS AT 50 Hz

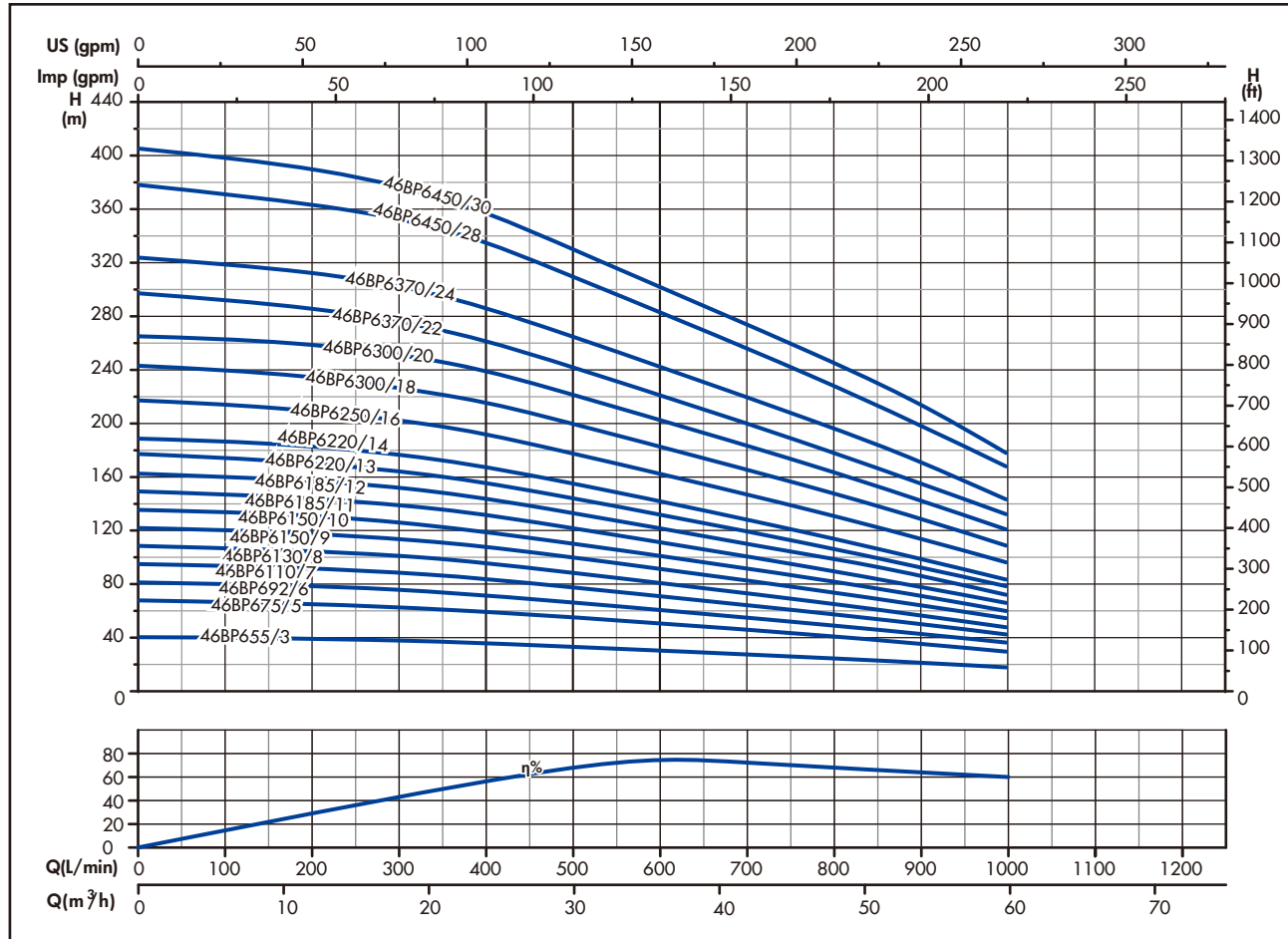

OPERATING CHARACTERISTICS AT 50 Hz

PUMP TYPE	No.OF STAGES	kW	Hp	Q=DELIVERY						
				l/min 0	400	500	617	766	917	1000
				m³/h 0	24	30	37	46	55	60
H=TOTAL HEAD METERS COLUMN OF WATER										
46BP655/3	3	5,5	7,5	41	36	33	29	26	21	18
46BP675/5	5	7,5	10	68	60	55	48	43	35	30
46BP692/6	6	9,2	12,5	81	72	66	58	51	42	36
46BP6110/7	7	11	15	95	84	77	67	60	49	42
46BP6130/8	8	13	17,5	108	96	88	77	68	56	48
46BP6150/9	9	15	20	122	108	99	86	77	63	54
46BP6150/10	10	15	20	135	120	110	96	85	70	60
46BP6185/11	11	18,5	25	149	132	121	106	94	77	66
46BP6185/12	12	18,5	25	162	144	132	115	102	84	72
46BP6220/13	13	22	30	176	156	143	125	111	91	78
46BP6220/14	14	22	30	189	168	154	134	119	98	84
46BP6250/16	16	25	35	216	192	176	154	136	112	96
46BP6300/18	18	30	40	243	216	198	173	153	126	108
46BP6300/20	20	30	40	270	240	220	192	170	140	120
46BP6370/22	22	37	50	297	264	242	211	187	154	132
46BP6370/24	24	37	50	324	288	264	230	204	168	144
46BP6450/28	28	45	60	378	336	308	269	238	196	168
46BP6450/30	30	45	60	405	360	330	288	255	210	180

DIMENSIONS AND WEIGHTS AT 50 Hz

PUMP TYPE	No.OF STAGES	DN	L mm	PUMP WEIGHT kg
46BP655/3	3	Rp4" (Rp3")	608	11,4
46BP675/5	5		834	15,8
46BP692/6	6		947	18
46BP6110/7	7		1060	20,2
46BP6130/8	8		1173	22,4
46BP6150/9	9		1286	24,6
46BP6150/10	10		1399	26,8
46BP6185/11	11		1512	29
46BP6185/12	12		1625	31,2
46BP6220/13	13		1738	33,4
46BP6220/14	14		1851	35,6
46BP6250/16	16		2077	40
46BP6300/18	18		2303	44,4
46BP6300/20	20		2529	48,8
46BP6370/22	22		2755	53,2
46BP6370/24	24		2981	57,6
46BP6450/28	28		3433	66,4
46BP6450/30	30	3659	70,8	

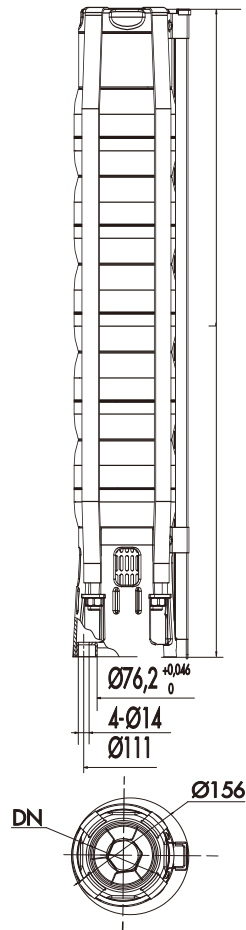

60BP SERIES

OPERATING CHARACTERISTICS AT 50 Hz

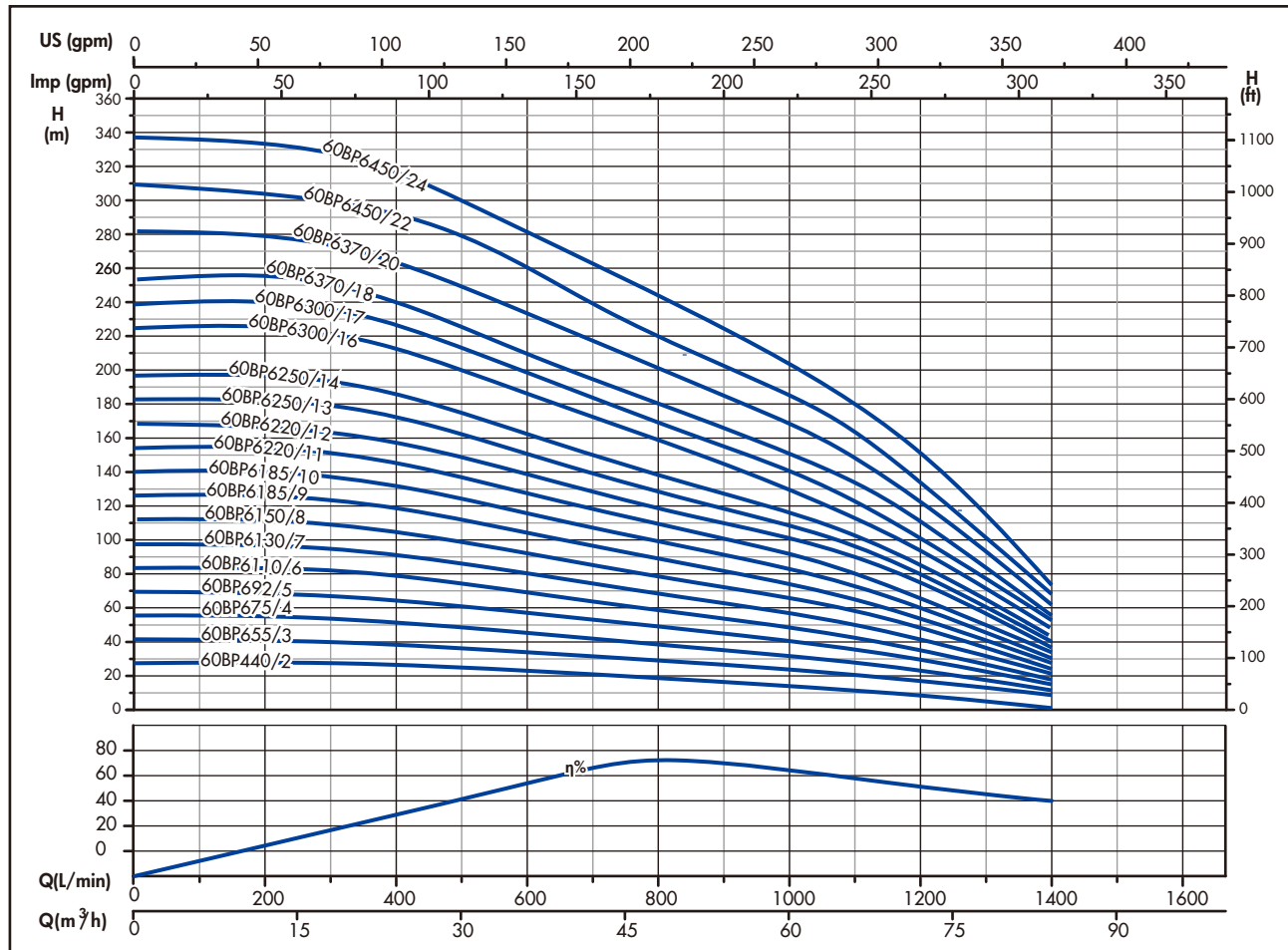

OPERATING CHARACTERISTICS AT 50 Hz

PUMP TYPE	No. OF STAGES	kW	Hp	Q=DELIVERY						
				l/min 0	300	500	800	1000	1200	1333
				m³/h 0 18 30 48 60 72 80						
				H=TOTAL HEAD METERS COLUMN OF WATER						
60BP440/2	2	4	5,5	28	27	25	18	16	11	6
60BP655/3	3	5,5	7,5	42	41	37	28	24	16	9
60BP675/4	4	7,5	10	56	55	49	38	32	21	12
60BP692/5	5	9,2	12,5	70	69	61	47	40	27	16
60BP6110/6	6	11	15	83	82	73	56	48	32	19
60BP6130/7	7	13	17,5	97	96	85	66	56	37	22
60BP6150/8	8	15	20	111	110	98	75	64	42	25
60BP6185/9	9	18,5	25	125	122	110	85	72	48	28
60BP6185/10	10	18,5	25	139	138	122	94	80	53	31
60BP6220/11	11	22	30	153	151	134	103	88	58	34
60BP6220/12	12	22	30	167	165	146	113	96	64	37
60BP6250/13	13	25	35	181	179	159	122	104	69	40
60BP6250/14	14	25	35	195	193	171	132	112	74	43
60BP6300/16	16	30	40	222	221	195	150	128	85	50
60BP6370/17	17	37	50	236	235	207	160	136	90	53
60BP6370/18	18	37	50	250	248	220	169	144	95	56
60BP6370/20	20	37	50	278	276	244	188	160	106	62
60BP6450/22	22	45	60	306	304	268	207	176	117	68
60BP6450/24	24	45	60	334	331	293	226	192	127	74

DIMENSIONS AND WEIGHTS AT 50 Hz

PUMP TYPE	No.OF STAGES	DN	L mm	PUMP WEIGHT kg
60BP640/2	2	Rp4" (Rp3")	495	9,9
60BP655/3	3		608	12,6
60BP675/4	4		721	14,9
60BP692/5	5		834	17,1
60BP6110/6	6		947	19,4
60BP6130/7	7		1060	21,6
60BP6150/8	8		1173	23,8
60BP6185/9	9		1286	26,1
60BP6185/10	10		1399	28,3
60BP6220/11	11		1512	30,6
60BP6220/12	12		1625	32,8
60BP6250/13	13		1738	35
60BP6250/14	14		1851	37,3
60BP6300/16	16		2077	41,8
60BP6370/17	17		2190	44
60BP6370/18	18		2303	46,2
60BP6370/20	20		2529	50,7
60BP6450/22	22		2755	55,2
60BP6450/24	24		2981	60

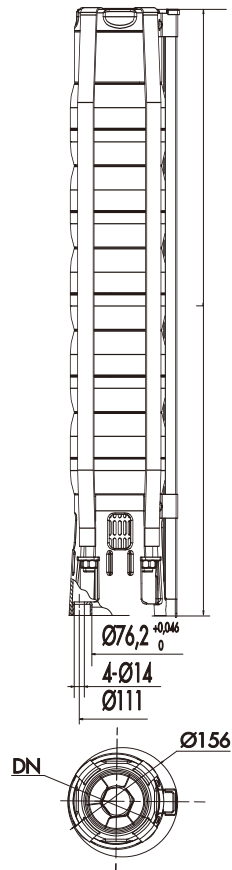

DP SERIES 8" SUBMERSIBLE PUMPS

- Completely made of corrosion-resistant stainless steel AISI 304, DP pumps are ideal for a wide variety of applications with high efficiency and reliability.

APPLICATIONS

- Water supply from deep well.
- Agricultural irrigation.
- Pressure boosting.
- Fire-fighting.
- Industrial application.

SPECIFICATIONS

- Delivery: up to 120 m³/h at 2850 rpm.
- Head: up to 249 m at 2850 rpm.
- Maximum overall diameter of pump: 172 mm (one cable guard included).
- Maximum permissible quantity of suspended sand: 150 g/m³.
- 77DP , 95DP Standard delivery port: Rp 5".

MOTOR

- Three-phase:
from 5,5 to 45 kW, 380 V, 50 Hz.

CONSTRUCTION CHARACTERISTICS

- Sturdy and lightweight, easy to maintain and resistant to corrosion in non-aggressive environments.
- High efficient hydraulic design for cost saving and best performance.
- Stainless steel built-in non-return valve.
- Stainless steel impellers and diffusers.
- Stainless steel delivery port and suction support.
- Stainless steel shaft and replaceable coupling.
- Coupling and flange mounting dimensions meet NEMA standards.

OPTIONAL FEATURES

- Different voltage and frequency.



DP SERIES

HYDRAULIC PERFORMANCE RANGE AT 50 Hz

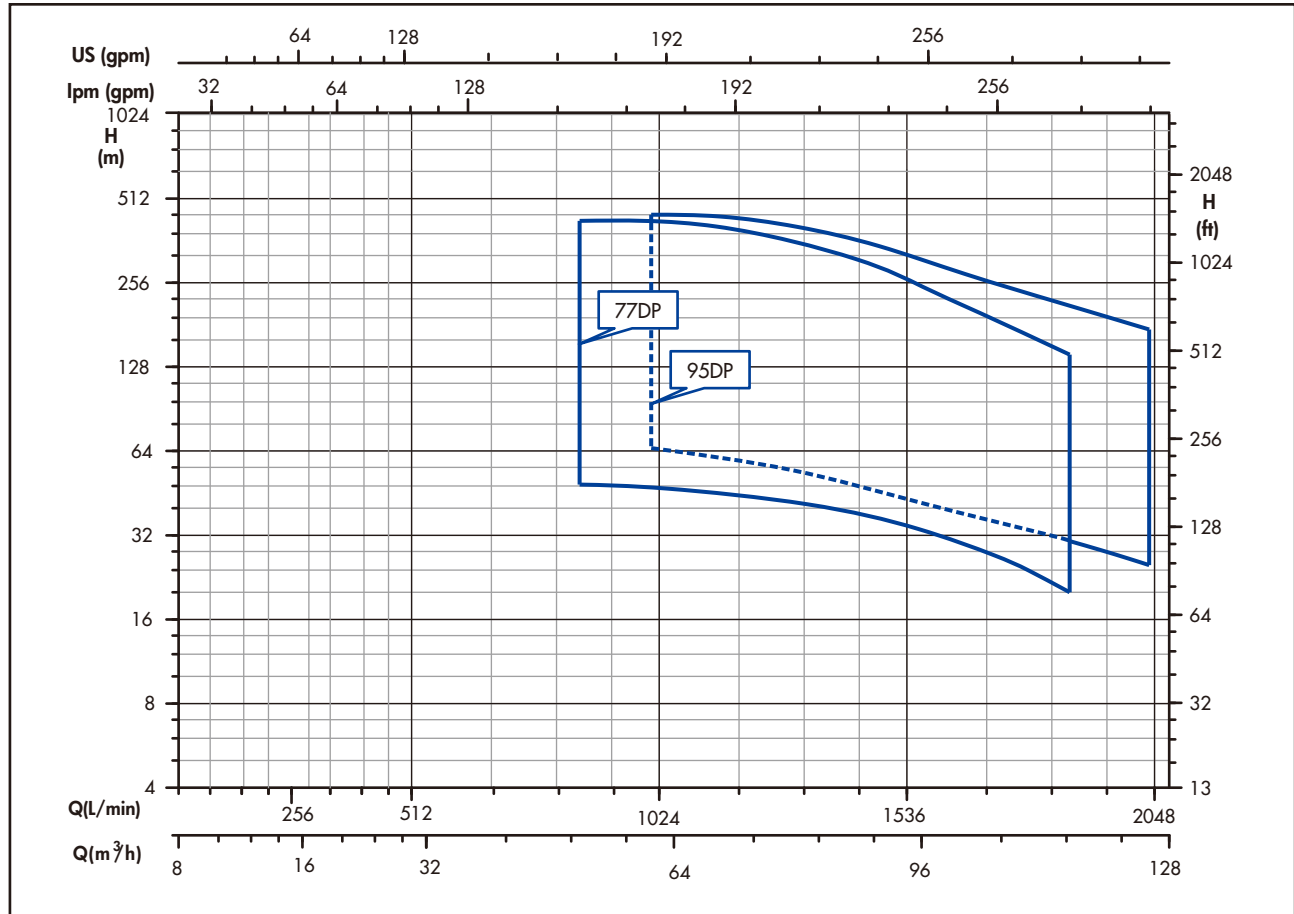

IDENTIFICATION CODE

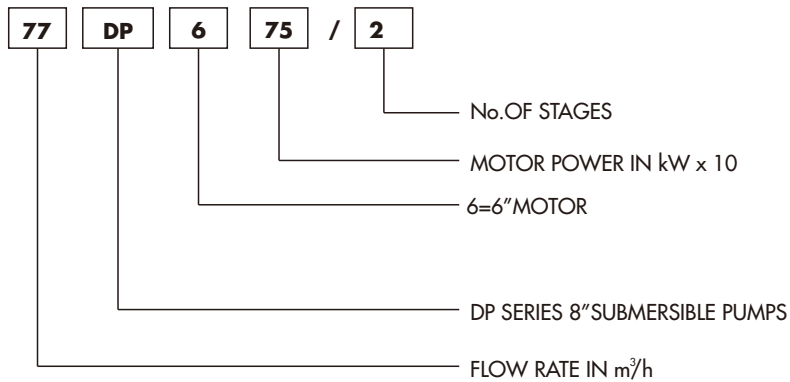

EXAMPLE OF PUMP TYPE

77DP675/2

BP series submersible pump with flow rate 77 m³/h, No. OF stages 2, and 6" submersible motor 7,5 kW (10 Hp).



77-95DP SERIES

PUMP SECTION AND LIST OF MAIN COMPONENTS MATERIAL

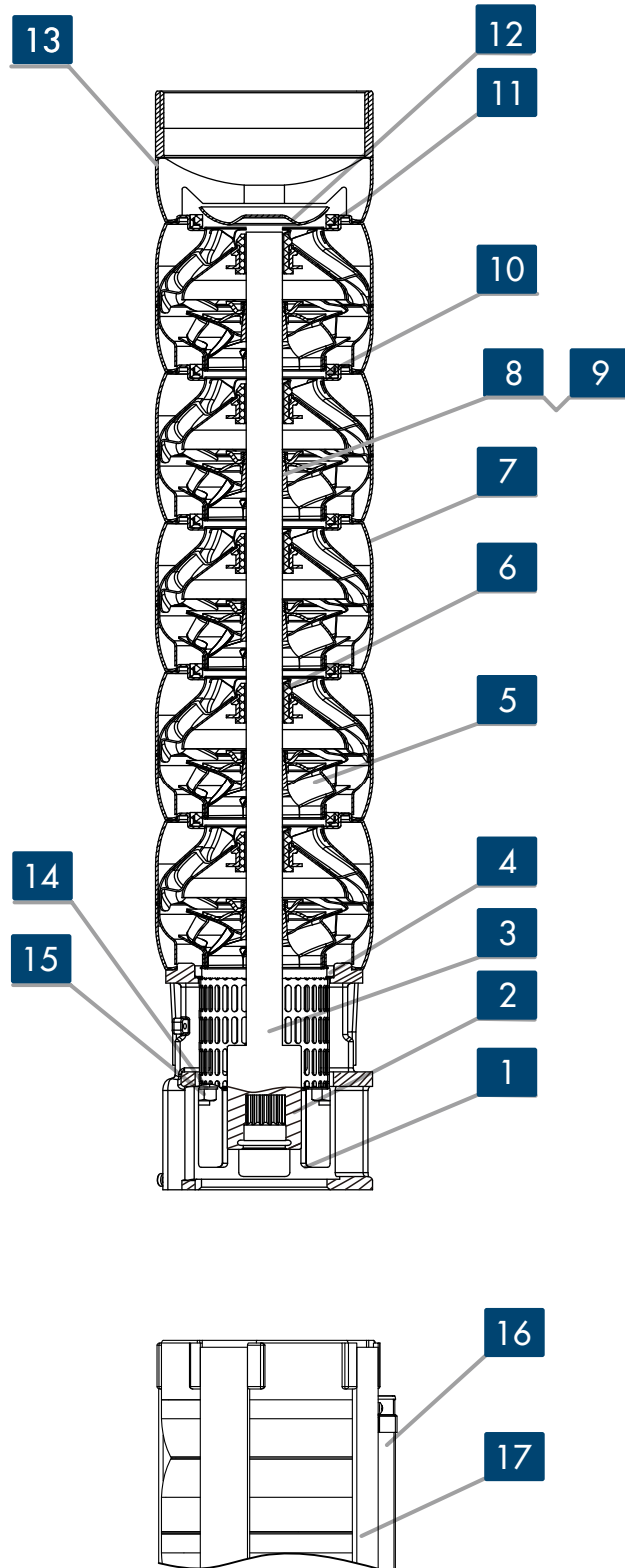

REF.N.	PART	MATERIAL	STANDARD
1	Lower support	Precision-cast stainless steel	AISI 304
2	Coupling	Stainless steel	AISI 304
3	Shaft	Stainless steel	AISI 304
4	First neck ring	NBR	-----
5	Impeller	Stainless steel	AISI 304
6	Bush bearing	NBR	-----
7	Diffuser	Stainless steel	AISI 304
8	Split cone	Stainless steel	AISI 304
9	Split cone nut	Stainless steel	AISI 304
10	Neck ring	NBR	-----
11	Valve support	NBR	-----
12	Non-return valve	Stainless steel	AISI 304
13	Delivery port	Precision-cast stainless steel	AISI 304
14	Washer	Stainless steel	AISI 304
15	Nut for strap	Stainless steel	AISI 304
16	Cable guard	Stainless steel	AISI 304
17	Strap	Stainless steel	AISI 304

77DP SERIES

OPERATING CHARACTERISTICS AT 50 Hz

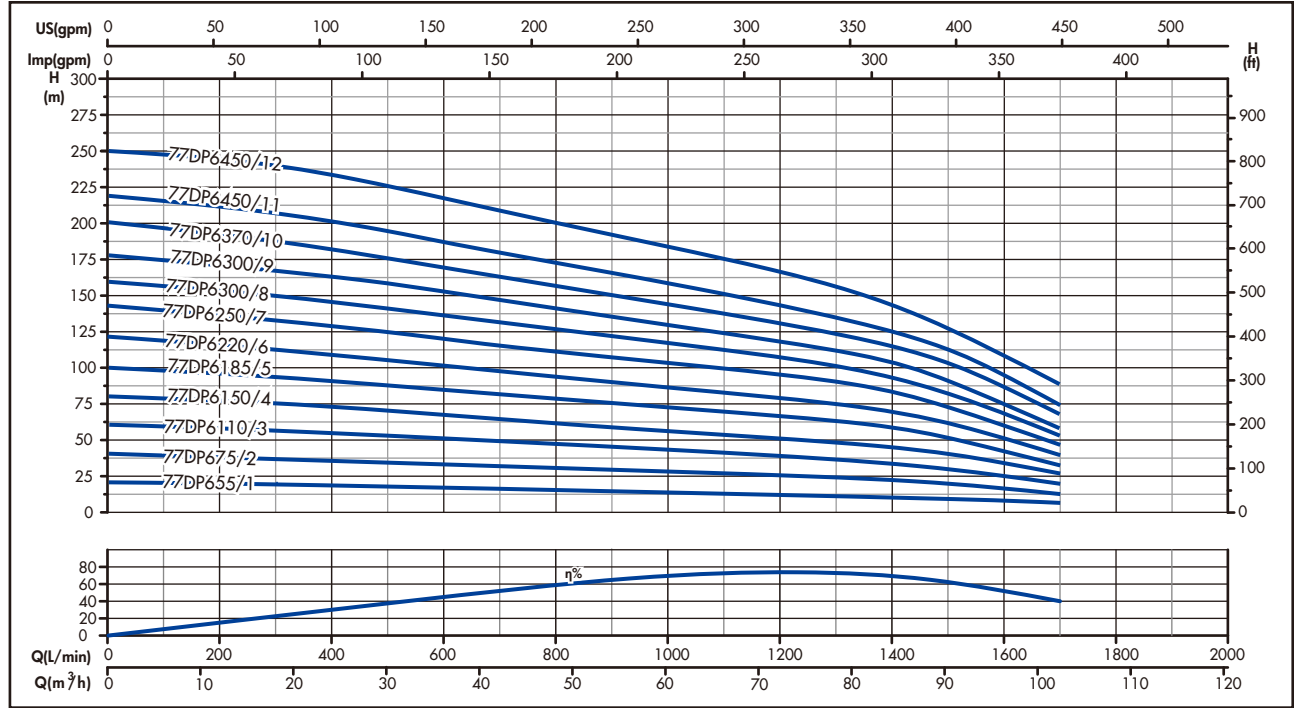

OPERATING CHARACTERISTICS AT 50 Hz

PUMP TYPE	No.OF STAGES	kW	Hp	Q=DELIVERY					
				l/min	300	600	900	1283	1700
				0	18	36	54	77	102
				H=TOTAL HEAD METERS COLUMN OF WATER					
77DP655/1	1	5,5	7,5	21	20	17	14	13	7
77DP675/2	2	7,5	10	41	37	33	28	27	13
77DP6110/3	3	11	15	61	57	50	43	40	20
77DP6150/4	4	15	20	80	76	67	58	53	27
77DP6185/5	5	18,5	25	100	94	84	73	67	33
77DP6220/6	6	22	30	121	113	101	88	80	40
77DP6250/7	7	25	35	142	133	120	104	94	47
77DP6300/8	8	30	40	159	150	135	117	107	53
77DP6300/9	9	30	40	177	167	152	131	117	58
77DP6370/10	10	37	50	200	188	168	145	133	68
77DP6450/11	11	45	60	218	207	186	159	147	74
77DP6450/12	12	45	60	249	240	217	190	160	99

DIMENSIONS AND WEIGHTS AT 50 Hz

PUMP TYPE	No.OF STAGES	DN	L mm	PUMP WEIGHT kg
77DP655/1	1	Rp5"	392	13,2
77DP675/2	2		496	16,4
77DP6110/3	3		600	19,5
77DP6150/4	4		704	22,7
77DP6185/5	5		808	25,9
77DP6220/6	6		912	29
77DP6250/7	7		1016	32,2
77DP6300/8	8		1120	35,4
77DP6300/9	9		1224	38,6
77DP6370/10	10		1328	41,7
77DP6450/11	11		1432	44,9
77DP6450/12	12		1536	48

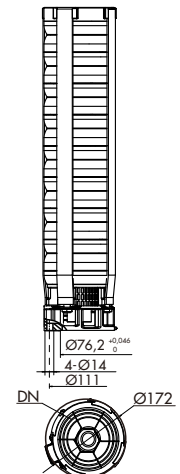

95DP SERIES

OPERATING CHARACTERISTICS AT 50 Hz

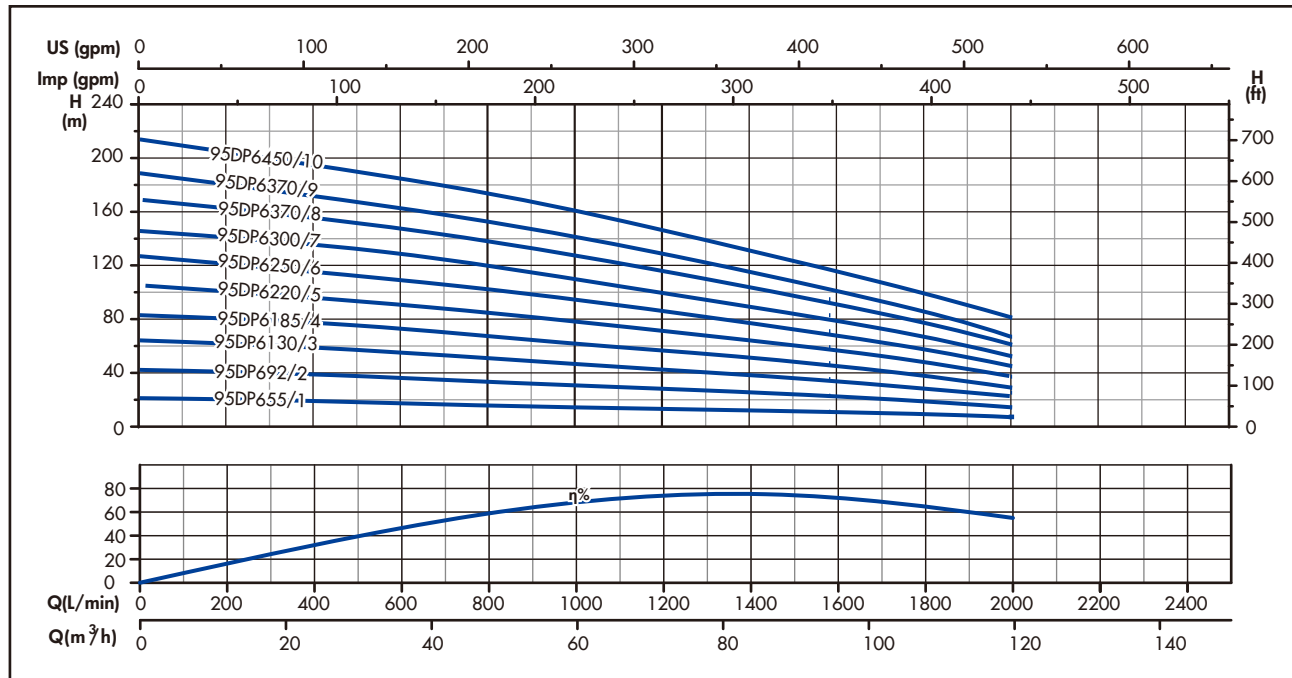

OPERATING CHARACTERISTICS AT 50 Hz

PUMP TYPE	No. OF STAGES	kW	Hp	Q=DELIVERY					
				l/min 0	300	600	1000	1583	2000
				H=TOTAL HEAD METERS COLUMN OF WATER					
95DP655/1	1	5,5	7,5	22	21	18	15	12	8
95DP692/2	2	9,2	12,5	43	41	37	31	24	15
95DP6130/3	3	13	17,5	65	62	57	47	36	26
95DP6185/4	4	18,5	25	84	82	75	62	48	30
95DP6220/5	5	22	30	106	102	94	77	60	38
95DP6250/6	6	25	35	128	123	114	94	72	46
95DP6300/7	7	30	40	147	143	132	110	84	53
95DP6370/8	8	37	50	170	164	152	126	96	62
95DP6370/9	9	37	50	190	182	169	140	108	68
95DP6450/10	10	45	60	215	206	190	162	120	82

DIMENSIONS AND WEIGHTS AT 50 Hz

PUMP TYPE	No. OF STAGES	DN	L mm	PUMP WEIGHT kg
95DP655/1	1	Rp5"	416	13,2
95DP692/2	2		544	17
95DP6130/3	3		672	20,8
95DP6185/4	4		800	24,6
95DP6220/5	5		928	28,4
95DP6250/6	6		1056	32,2
95DP6300/7	7		1184	36
95DP6370/8	8		1312	39,7
95DP6370/9	9		1440	43,5
95DP6450/10	10		1568	47,3

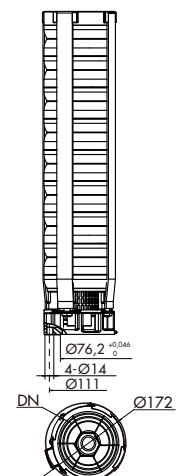

CBS SERIES SINGLE-PHASE ELECTRIC PANELS

APPLICATIONS

- Protection and control of single-phase submersible electric pump for 4" wells.

SPECIFICATIONS

- Supply voltage: 1 x 220 V $\pm 5\%$.
- Frequency: 50 Hz.
- Power: 0,25 to 2,2 kW.
- Protection class: IP54.
- Ambient temperature: 0 °C to +40 °C.
- Relative humidity: $\leq 90\%$
- Altitude: ≤ 2000 m



CONSTRUCTION & CHARACTERISTICS

- Main switch for manual control.
- Direct motor start.
- Mounting mode: wall mounted.
- Plastic enclosure
- Incorporated capacitor.
- Thermal protection with motor protector inside the panel.

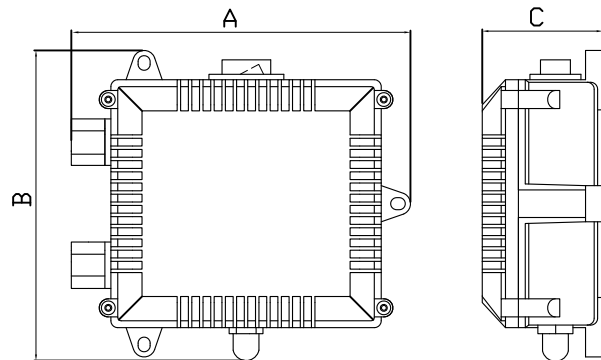

PANEL TYPE	VOLTAGE V	POWER		CURRENT A	CAPACITOR $\mu\text{F}/450\text{V}$	A mm	B mm	C mm	WEIGHT kg
		kW	Hp						
CBS02S	220	0,25	0,33	2,35	16	195	177	70	0,48
CBS03S	220	0,37	0,5	3,3	22	195	177	70	0,49
CBS05S	220	0,55	0,75	4,63	25	195	177	70	0,50
CBS07S	220	0,75	1	6,0	40	195	177	70	0,54
CBS11S	220	1,1	1,5	8,4	60	195	177	70	0,61
CBS15S	220	1,5	2	11,0	65	195	177	70	0,69
CBS22S	220	2,2	3	15,8	70	195	177	70	0,73

CBL SERIES SINGLE-PHASE ELECTRIC PANELS

APPLICATIONS

- Protection and control of single-phase submersible electric pump for 4" wells.

SPECIFICATIONS

- Supply voltage: 1 x 220 V $\pm 5\%$.
- Frequency: 50Hz.
- Power: 0,25 to 1,1 kW.
- Protection class: IP54.
- Ambient temperature: 0°C to +40°C.
- Relative humidity: $\leq 90\%$.
- Altitude: ≤ 2000 m.



CONSTRUCTION & CHARACTERISTICS

- Dry running protection.
- Blocking protection.
- Over voltage protection.
- Over current protection.
- Low voltage protection.
- HD LCD display.
- Quick five faults record query.
- Pump total run time query.
- Failure alarm.
- One key resetting

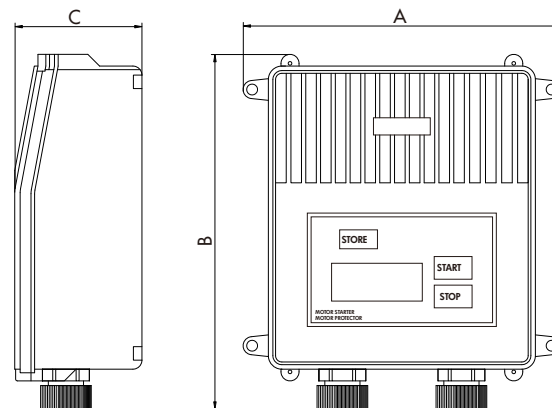

PANEL TYPE	VOLTAGE V	POWER		CURRENT A	CAPACITOR $\mu\text{F}/450\text{V}$	A mm	B mm	C mm	WEIGHT kg
		kW	Hp						
CBL02S	220	0,25	0,33	2,35	16	150	185	67	0,46
CBL03S	220	0,37	0,5	3,3	22	150	185	67	0,48
CBL05S	220	0,55	0,75	4,63	25	150	185	67	0,48
CBL07S	220	0,75	1	6,0	30	150	185	67	0,5
CBL11S	220	1,1	1,5	8,4	43	150	185	67	0,67

CBS SERIES THREE-PHASE ELECTRIC PANELS (0,37~7,5kW)

APPLICATIONS

- Protection and control of three-phase surface or submersible electric pump.

SPECIFICATIONS

- Supply voltage: 3 x 380 V \pm 10%.
- Frequency: 50/60 Hz.
- Power: 0,37 to 7,5 kW.
- Protection class: IP54.
- Ambient temperature: 0°C to +40°C.
- Relative humidity: \leq 90%.
- Altitude: \leq 2000 m.



CONSTRUCTION & CHARACTERISTICS

- Control mode: Manual/Automatic.
- Direct motor start.
- Over current protection.
- Motor stalling protection.
- Short-circuit protection.
- Phase loss protection.
- No sensor dry running protection.
- Undervoltage / overvoltage protection.
- Liquid level control: pulse electrode sensor or float switch detection.
- Pressure control: tri-wire electric contact pressure gauge/dual-wire pressure switch.
- Display: HD LCD dynamic display.
- Complete protection function under automatic/manual mode.
- Quick five faults record query.
- Pump total run time query.
- Liquid level/pressure direct interconvert switch.
- LCD voltage/current display.
- Installation mode: wall mounted.
- Plastic case

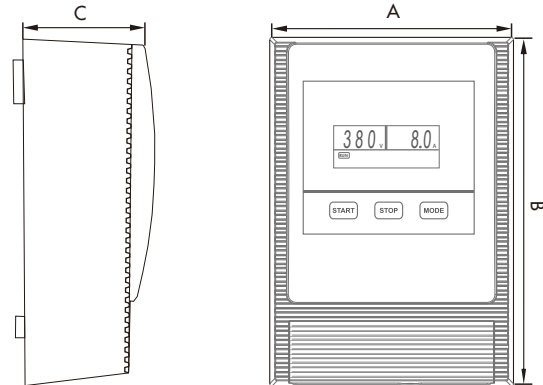

PANEL TYPE	VOLTAGE V	POWER		CURRENT A	A mm	B mm	C mm	WEIGHT kg
		kW	Hp					
CBS03T	380	0,37	0,5	1,4	160	228	73	1,2
CBS05T	380	0,55	0,75	2,5	160	228	73	1,2
CBS07T	380	0,75	1	2,5	160	228	73	1,2
CBS11T	380	1,1	1,5	3,4	160	228	73	1,2
CBS15T	380	1,5	2	4,4	160	228	73	1,2
CBS22T	380	2,2	3	6,2	160	228	73	1,2
CBS30T	380	3	4	8,3	160	228	73	1,2
CBS40T	380	4	5,5	10,8	160	228	73	1,2
CBS55T	380	5,5	7,5	14,4	160	228	73	1,2
CBS75T	380	7,5	10	19,0	160	228	73	1,2

CBS SERIES THREE-PHASE ELECTRIC PANELS (9,2~15kW)

APPLICATIONS

- Protection and control of three-phase surface or submersible electric pump.

SPECIFICATIONS

- Supply voltage: 3 x 380 V \pm 10%.
- Frequency: 50/60 Hz.
- Power: 9,2 to 15 kW.
- Protection class: IP54.
- Ambient temperature: 0°C to +40°C.
- Relative humidity: \leq 90%.
- Altitude: \leq 2000 m.



CONSTRUCTION & CHARACTERISTICS

- Control mode: Manual/Automatic.
- Direct motor start.
- Over current protection.
- Motor stalling protection.
- Short-circuit protection.
- Phase loss protection.
- No sensor dry running protection.
- Undervoltage/overvoltage protection.
- Liquid level control: pulse electrode sensor or float switch detection.
- Pressure control: tri-wire electric contact pressure gauge/dual-wire pressure switch.
- Display: HD LCD dynamic display.
- Complete protection function under automatic/manual mode.
- Quick five faults record query.
- Pump total run time query.
- Liquid level/pressure direct interconvert switch.
- LCD voltage/current display.
- Installation mode: wall mounted.
- Plastic case

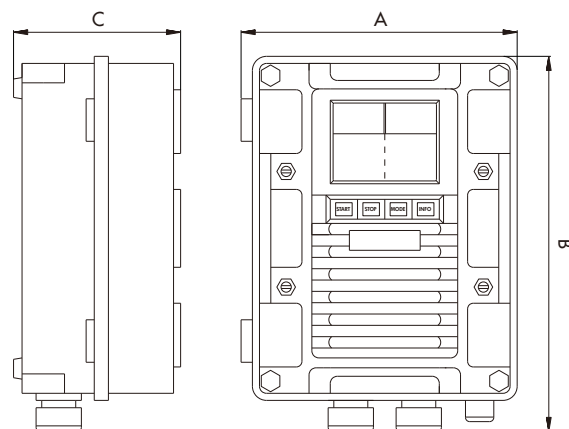

PANEL TYPE	VOLTAGE V	POWER		CURRENT A	A mm	B mm	C mm	WEIGHT kg
		kW	Hp					
CBS92T	380	9,2	12,5	22,4	195	270	112	1,8
CBS110T	380	11	15	26,5	195	270	112	1,8
CBS130T	380	13	17,5	30,9	195	270	112	1,8
CBS150T	380	15	20	36,0	195	270	112	1,8



TEL. +39 0522/736052

FAX +39 0522/736526

SEDE LEGALE E OPERATIVA:

Via della Tecnica n.5-42015 Prato di Correggio (RE) Italy

P.iva/Cod.Fisc 02287380972

N°REA RE-298452

Capitale sociale €50.000,00i. v.

E-mail: newjetsrl@hotmail.com

www.ircempump.com

NEW JET S.R.L.